

SIZE	INLET	OUTLET	MAX WORKING PRESSURE
2" X 1"	2" NPT	1" NPT	150 PSI (1034 KPa)
2" X 2"	2" NPT	2" NPT	
3" X 2"	3" NPT	2" NPT	

WEIGHT - 60 LBS (27 KG)

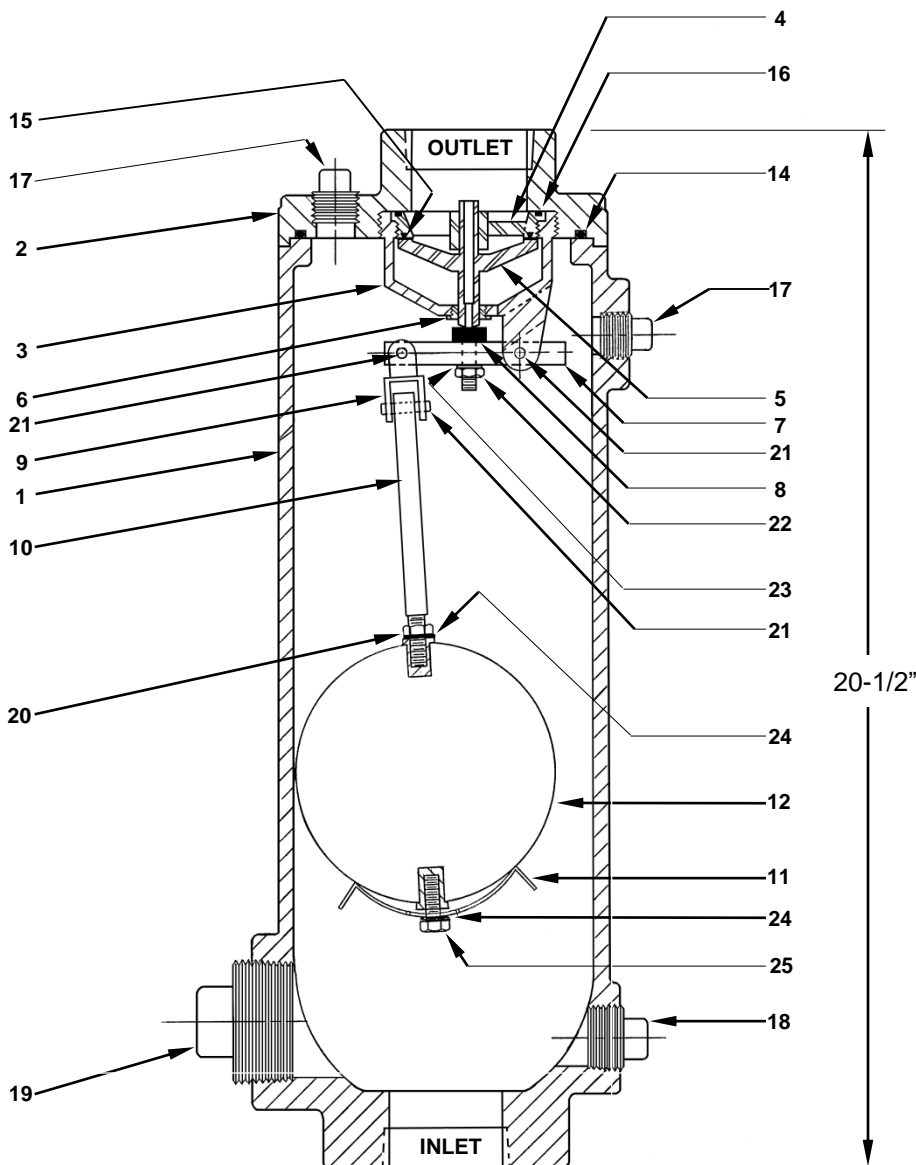

GA INDUSTRIES, a VAG Brand

DATE:	3-7-09	DRAWN BY:	WJN
-------	--------	-----------	-----

SINGLE BODY SEWAGE COMBINATION AIR VALVE

FIGURE 942	DRAWING NO. ECAV7104-W	REV A
-------------------	----------------------------------	-----------------

LIST of MATERIALS

2" x 1", 2" x 2" & 3" x 2" Figure 942

Refer to Drawing ECAV7104-W

ITEM	NAME	MATERIAL
1	Body	Cast Iron, ASTM A126 Class B
2	Cover	Cast Iron, ASTM A126 Class B
3	Cage	316 Stainless Steel, ASTM A351 Gr CF8M
4	Seat	316 Stainless Steel
5	Plug	316 Stainless Steel
6	Bushing	316 Stainless Steel
7	Lever Arm	316 Stainless Steel
8	Orifice Button	Buna-N & Stainless Steel
9	Universal Coupling	316 Stainless Steel
10	Float Rod	316 Stainless Steel
11	Float Hood	316 Stainless Steel
12	Float Ball	316 Stainless Steel
13	Cover Bolt	Zinc Plated Steel (Standard) 316 Stainless Steel (Optional)
14	Cover O-Ring	Buna-N
15	Renewable Seat	Buna-N
16	Cage O-Ring	Buna-N
17	½" NPT Pipe Plug	Steel
18	1" NPT Pipe Plug	Cast Iron
19	2" NPT Pipe Plug	Malleable Iron
20	Hex Nut	18-8 Stainless Steel
21	Spirol Pin	302 Stainless Steel
22	Hex Nut	18-8 Stainless Steel
23	Lock Washer	18-8 Stainless Steel
24	Lock Washer	18-8 Stainless Steel
25	Cap Screw	18-8 Stainless Steel

GA INDUSTRIES, a VAG Brand		
DATE:	3/9/09	DRAWN BY: WJN
SEWAGE COMBINATION AIR VALVE LIST OF STANDARD MATERIALS		
2"X1", 2" & 3" X2" FIGURE 942	DRAWING NO. ECAV7104.01	REV A