

VALVE DIMENSIONS

SIZE	A		B		C		F		J		L	
	IN.	MM	IN.	MM	IN.	MM	IN.	MM	IN.	MM	IN.	MM
30"	51	1295	26 3/8	670	28 1/2	724	39 1/8	994	1 13/16	46	68 5/8	1743
36"	60	1524	28 13/16	732	31	787	46	1168	2	51	73 5/8	1870

PARTS LIST	
ITEM NO.	DESCRIPTION
20	GEARBOX ACTUATOR
21	ACTUATOR BOLTS

SEAT END

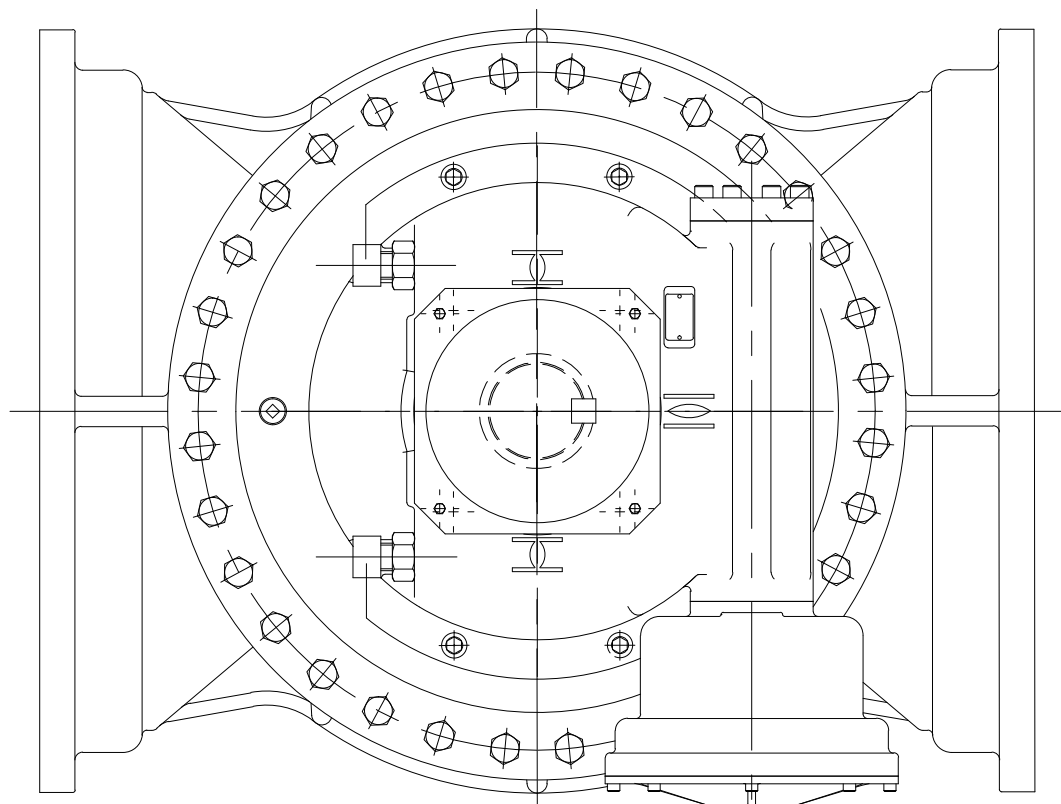

- NOTES:
 1. FLANGE DRILLING PER ANSI A21.1 AWWA C111
 2. IN COMPLIANCE WITH AWWA C517
 3. COLD WORKING PRESSURE: 150 PSI
 4. HYDROSTATIC TEST PRESSURE: 225 PSI

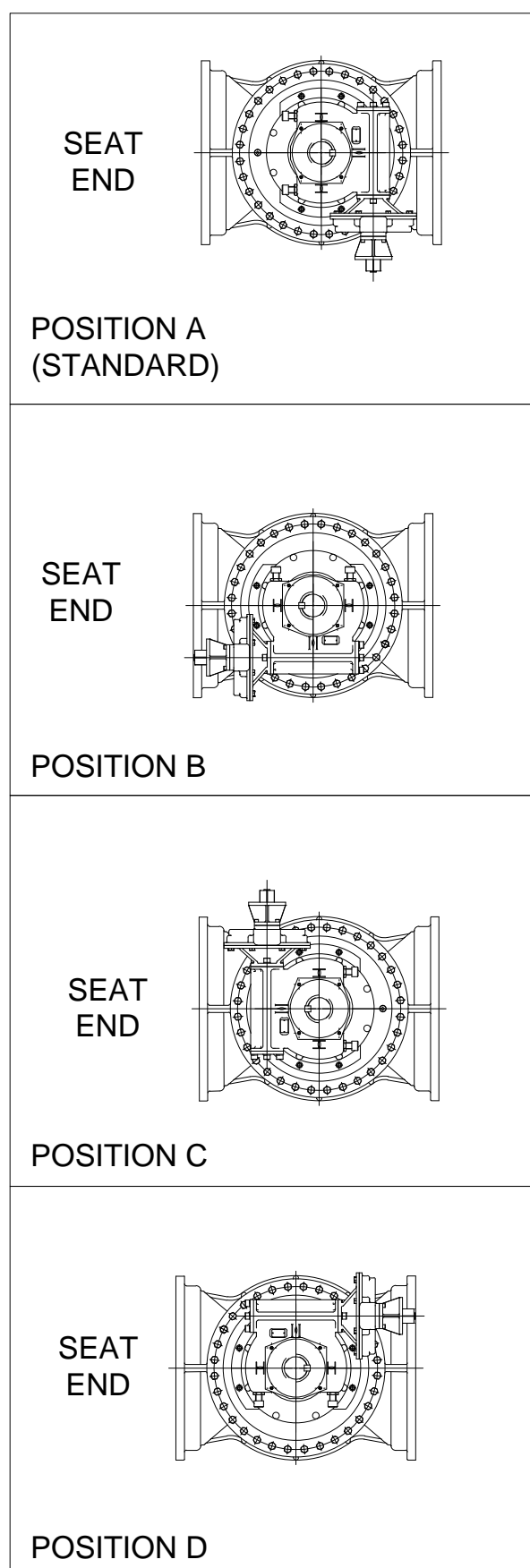
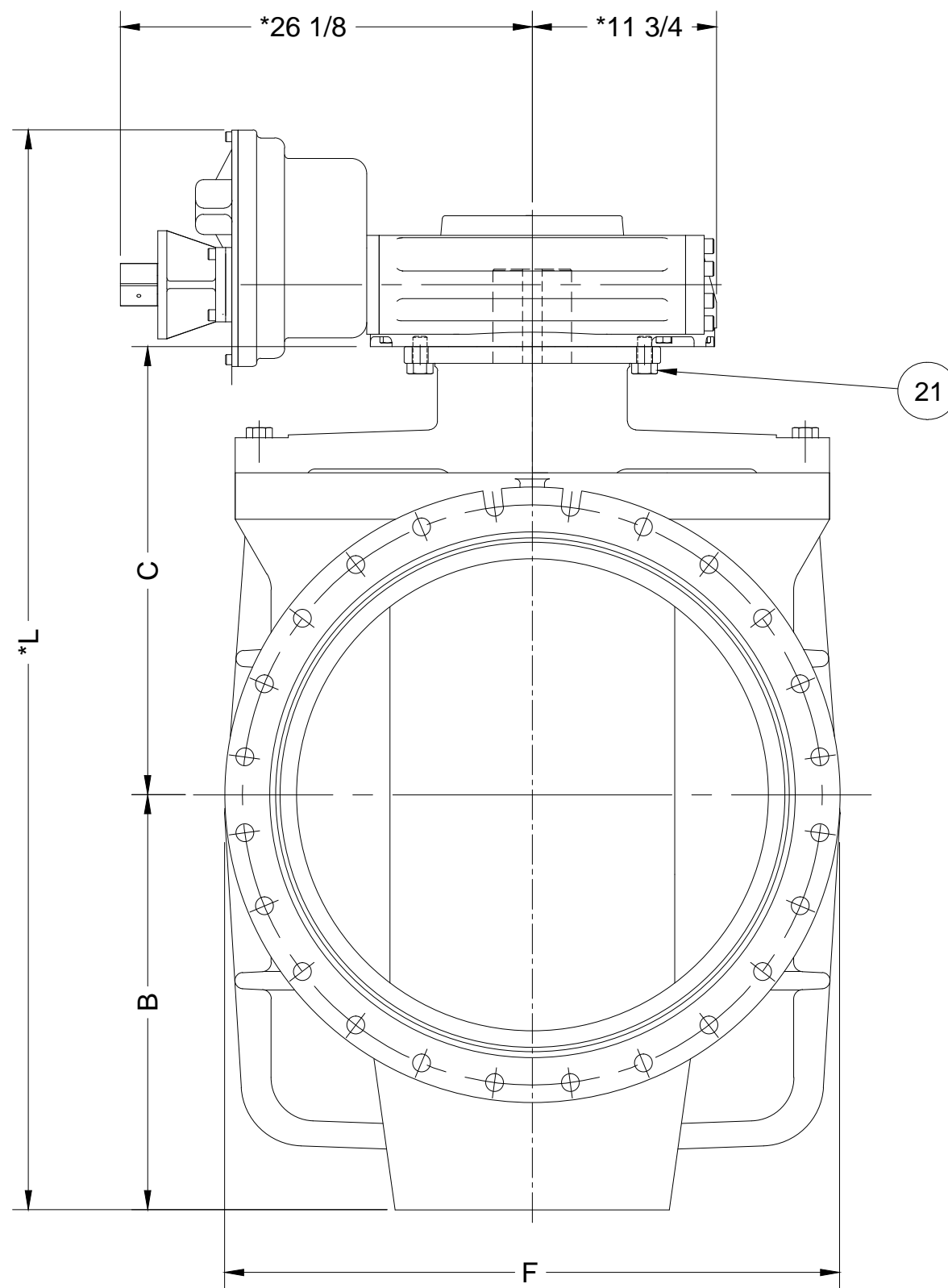
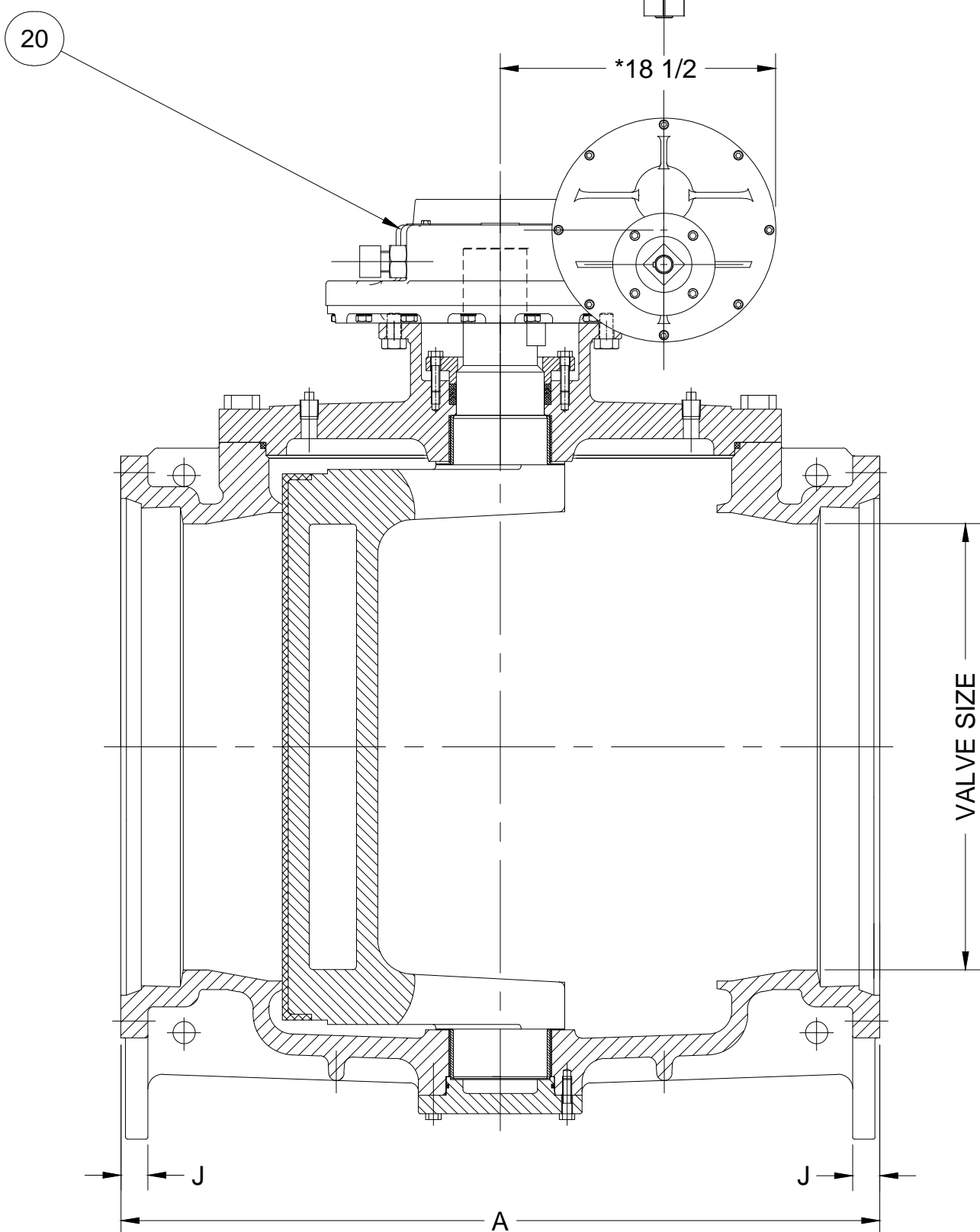

*NOTE: DIMENSION MAY VARY; REFER TO ACTUATOR DATA TO VERIFY.

DIMENSIONS IN INCHES	
STANDARD TOLERANCES (UNLESS OTHERWISE NOTED)	CASTING STOCK MINIMUM (FOR MACHINED SURFACES)
X = ±.1	0 TO <1 = 1/8
XX = ±.01	1 TO <6 = 3/16
XXX = ±.005	6 TO <12 = 1/4
FRACTIONS = ±1/64	12 AND > = 3/8
ANGLES = ±1°	
DRAFTS: 3° MAX	
PER ANSI Y14.5M GD&T <3/32 FLATNESS, ROUNDNESS, POSITION	

GA INDUSTRIES, LLC
 30"- 36" ECO-CENTRIC PLUG VALVE
 W/BURIED SERVICE ROTORK #IW9R MANUAL ACTUATOR
 (FA35 GEARBOX MOUNT) MECHANICAL JOINT FLANGES

SERIAL NO.	FIG. NUMBER	DATE	PROPERTY OF GA INDUSTRIES, LLC	DRAWN BY	DAK
	517	08-22-2017		APPR. BY	*
REFERENCES	FILE	DRAWING NO.	REV.		
	PL	PL-1149	*		

REV.	DESCRIPTION	DATE	BY
* * *			

O:\AUTOCAD\PLUG-PL-SHOWPL-1149.dwg

VALVE DIMENSIONS												
SIZE	A		B		C		F DIA		J		L	
	IN.	MM	IN.	MM	IN.	MM	IN.	MM	IN.	MM	IN.	MM
42"	72	1829	32 3/4	832	42 1/4	1073	53 1/8	1349	2	50.8	85 1/2	2172
48"	84	2134	36	914	45 1/2	1156	60	1524	2	50.8	92	2337

PARTS LIST	
ITEM NO.	DESCRIPTION
19	MANUAL GEARBOX ACTUATOR
20	ACTUATOR SPACER PLATE
21	ACTUATOR BOLTS

- NOTES:
 1. FLANGE DRILLING PER ANSI A21.1 AWWA C111
 2. IN COMPLIANCE WITH AWWA C517
 3. COLD WORKING PRESSURE: 150 PSI
 4. HYDROSTATIC TEST PRESSURE: 225 PSI

SEAT
END

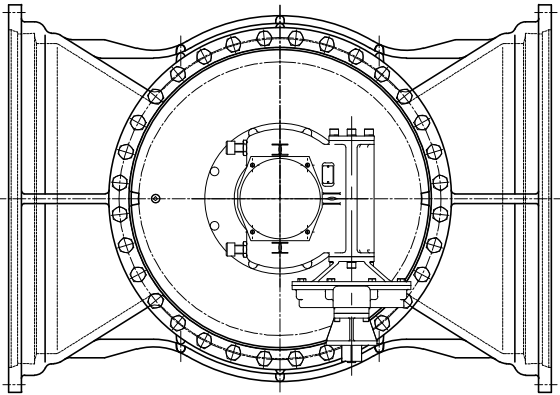

OPTIONAL MOTOR ACTUATOR POSITIONS:
 CUSTOMER TO SPECIFY POSITION WITH ORDER;
 POSITION "A" SHOWN ON MAIN VIEW.

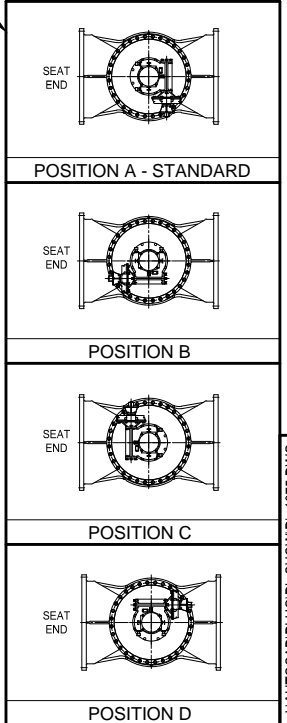
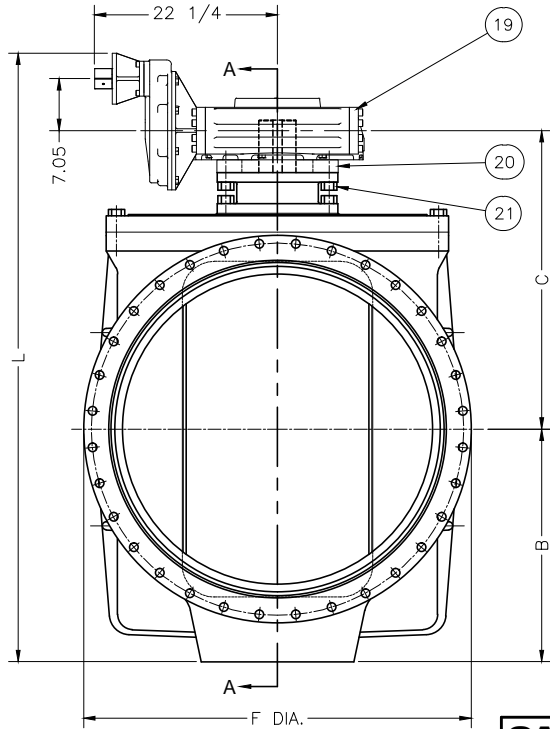
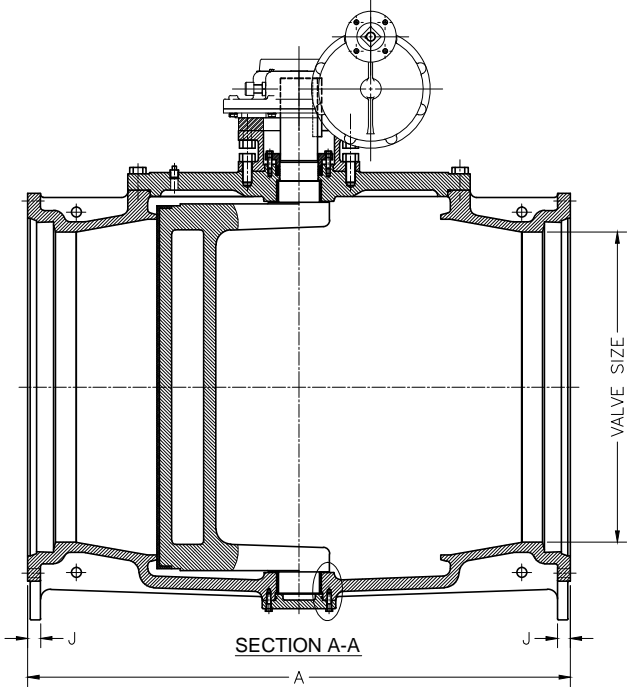

J:\AUTOCAD\PLUG\PL-SHOW\PL-1075.DWG

REV.	DESCRIPTION	DATE	BY

GA INDUSTRIES, LLC
 42"- 48" ECO-CENTRIC PLUG VALVE
 W/BURIED SERVICE ROTORK #IW85R ACTUATOR
 MECHANICAL JOINT FLANGES

SERIAL NO. 113332	DRAWN BY SWR
FIG. NO. 517	APPR. BY JT
DATE 05-01-2012	SCALE N.T.S.
PROPERTY OF GA INDUSTRIES, LLC	
REFERENCES	FILE PL
DRAWING NO. PL-1075	REV. *