

SIZE	6"	8"	10"	12"
A	21-5/8"	25-3/8"	29-7/8"	33-7/8"
B	20-3/4"	25-1/4"	33"	39-7/8"
C	15-1/4"	19"	23-1/2"	27-1/2"
D*	18"	21-1/2"	26-1/2"	34"
WGT	200 lb.	360 lb.	500 lb.	650 lb

* Air Vacuum Valve height without cowl

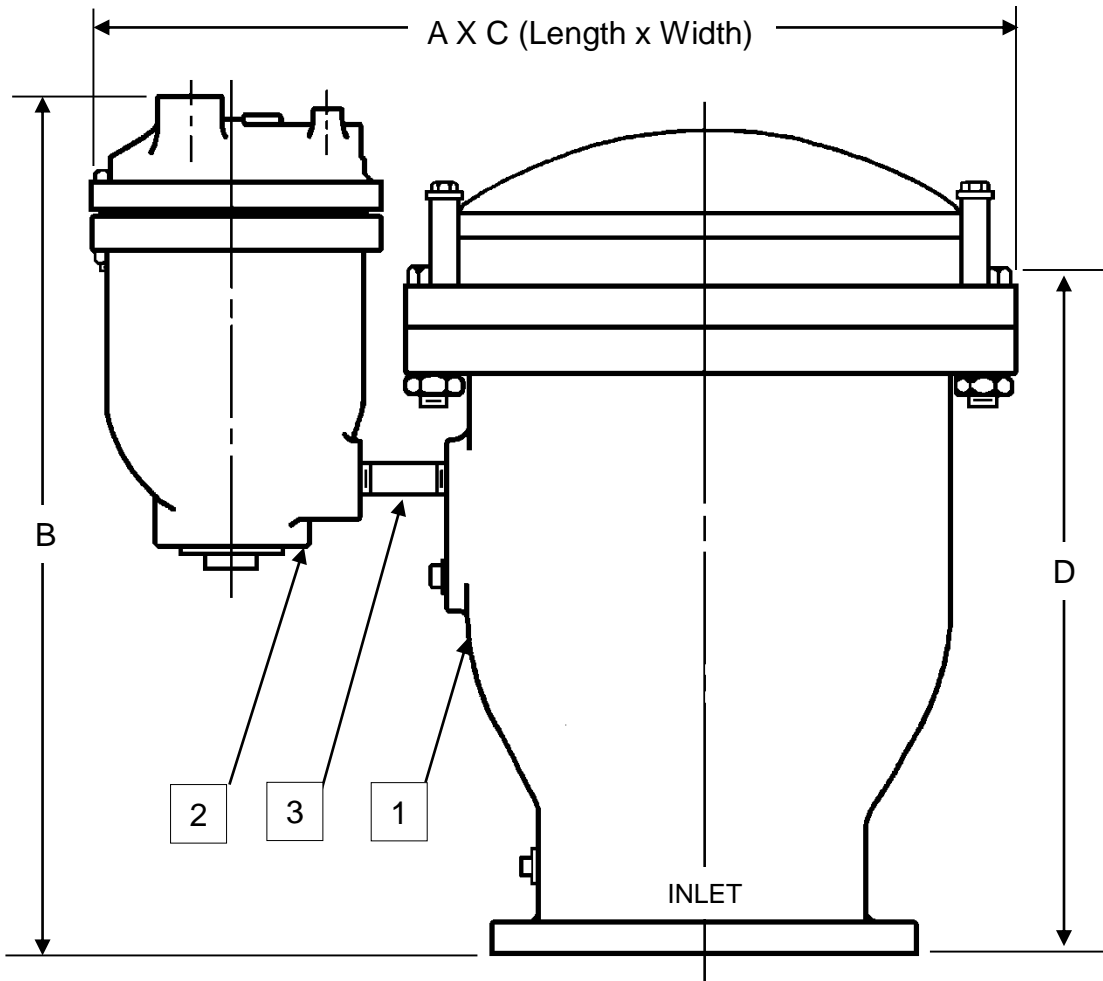

PARTS LIST		
Part	Name	Material
1	Figure 930 Air & Vacuum Valve	6" to 8" – Drawing EAV-7049-W 10" to 12" – Drawing EAV-7050-W
2	Figure 920 Air Release Valve	Drawing EAR-7003-W
3	Pipe Nipple	Brass

FIGURE NUMBER	INLET	OUTLET	MAXIMUM WORKING PRESSURE	PRESSURE RATING	HYDRO TEST PRESSURE
950-DC	ANSI CLASS 125	COWL	150 PSI	200 PSI	225 PSI
950-DJ	ANSI CLASS 125	ANSI CLASS 125	150 PSI	200 PSI	225 PSI
950-UHC	ANSI CLASS 250	COWL	300 PSI	300 PSI	450 PSI
950-UHJ	ANSI CLASS 250	ANSI CLASS 125	300 PSI	300 PSI	450 PSI

GA INDUSTRIES, a VAG Brand		
DATE:	1-15-09	DRAWN BY: WJN
6" to 12" DUAL BODY COMBINATION AIR VALVE		
Figure 950	DRAWING NO. ECAV-7166-W	REV A