

# INSTALLATION, OPERATION AND MAINTENANCE MANUAL

## 3", 4" and 6" Figures 955 and 955-D Dual Body Combination Air Valves for Sewage and Wastewater

### TABLE OF CONTENTS

Section 1	Figure 955 and 955-D Combination Air Valve
Section 2	Figure 935 and 935-D Air & Vacuum Valves
Section 3	Figure 925 Air Release Valve



234 Clay Avenue • Mars, PA 16046 USA  
Telephone (724) 776-1020 • Fax (724) 776-1254  
E-mail: [info-ga@vag-group.com](mailto:info-ga@vag-group.com)

Manual Number 955.02-IOM-090125 Rev A



WARNING: Cancer and Reproductive Harm – [www.Prop65Warnings.ca.gov](http://www.Prop65Warnings.ca.gov)

# Section 1

# INSTALLATION, OPERATION AND MAINTENANCE MANUAL

## 3", 4" and 6" Figures 955 and 955-D Dual Body Combination Air Valves for Sewage and Wastewater

### TABLE OF CONTENTS

Section 1	Figure 955 and 955-D Combination Air Valve
Section 2	Figure 935 and 935-D Air & Vacuum Valves
Section 3	Figure 925 Air Release Valve



234 Clay Avenue • Mars, PA 16046 USA  
Telephone (724) 776-1020 • Fax (724) 776-1254  
E-mail: [info-ga@vag-group.com](mailto:info-ga@vag-group.com)

Manual Number 955.02-IOM-090125 Rev A



WARNING: Cancer and Reproductive Harm – [www.Prop65Warnings.ca.gov](http://www.Prop65Warnings.ca.gov)

# Section 1

# INSTALLATION, OPERATION and MAINTENANCE

## 3", 4" and 6" Figure 955 and 955D Dual Body Combination Air Valves for Sewage

### INTRODUCTION

This manual provides information to install, operate and maintain GA Industries dual short body combination air valves to ensure a long service life. The valve is ruggedly constructed to provide many decades of dependable service with minimal maintenance.

### CAUTION

The valve is NOT recommended for use with toxic, corrosive, or flammable fluids.

The Shop Order (SO) Number, Figure Number, size, and pressure rating are stamped on a nameplate attached to the valve. Please refer to the SO number when ordering parts.

### DESCRIPTION OF OPERATION

These dual body combination air valves consist of two individual air valves assembled and piped together at the factory: a Figure 935 air & vacuum valve and a Figure 925 air release valve. Each valve is "normally open" and closes when water rises in the valve to lift the buoyant float and seal the orifice.

The Figure 935 air & vacuum valve has a large orifice that is the same size as the nominal size of the valve. During system filling, air is vented through the orifice at the same rate as the fluid is entering the system. When fluid rises in the valve it lifts the float to seal off the orifice. The valve will remain closed if there is positive pressure within the valve but automatically opens to admit air to alleviate the vacuum when the pipeline is drained and/or a negative pressure occurs inside the valve.

The Figure 925 air release valve has a small orifice that closes when fluid fills the valve. The valve's small orifice automatically opens to release air and sewage gas that accumulates in the valve while the system is pressurized and operational. The valve closes when the air is released. This cycle will occur as often as needed to prevent an excessive accumulation of air or sewage gas.

### CONSTRUCTION

The air valves that comprise the Figure 955 combination air valve have a cast iron body and cover, 316 stainless steel float and internal linkage mechanism and Buna-N seats.

### RECEIVING AND STORAGE

Inspect the valve upon receipt for damage during shipment. Carefully unload all valves to the ground without dropping.

Valves should remain in a clean, dry, and weather protected area until installed.

### INSTALLATION

The valve is typically installed at high points in the system where air and sewage gas naturally rise during filling and in operation and a vacuum first form during draining.

The combination air valve is installed on top of the pipeline in a vertical orientation. The 3" has a standard NPT connection to the forcemain, the 4" is available either NPT or Class 125 flanged while the 6" is standard with a Class 125 flanged connection. All valves have the same size NPT outlet.

An isolating valve should be installed between the air valve and the forcemain to facilitate maintenance.

Prior to installation ensure all debris, packing material or other foreign material has been removed from the valve.

If installed outdoors, below ground in a vault or in an unheated area, adequate freeze protection must be provided.

The valve should be installed with sufficient clearance to permit maintenance and removal of internal components.

Figures 955 (NPT inlet) and 955-D (flanged inlet) have a maximum working pressure of 150 PSI while the Figures 955L and 955-DL have a maximum working pressure of 75 PSI.

Lower heavy valves using slings or chains. Use appropriate sealant on threaded connections and screw valve assembly onto a pipe nipple.

### START-UP

The valve does not require any calibration or adjustment prior to start-up.

### PREVENTATIVE MAINTENANCE

No routine lubrication or adjustments are needed. Periodic visual inspection and testing should be performed to ensure the valve(s) are operating.

### REPAIR INSTRUCTIONS

Instructions for the inspection, troubleshooting and repair of the two valves utilized in the GA Industries Figure 925 and 935 are provided in the sections for each valve.

### REPLACEMENT PARTS

Refer to the individual valve sections for applicable repair kits and parts. Genuine replacement parts are available from your local GA Industries representative or from the factory:

VAG USA, LLC  
234 Clay Avenue  
Mars, PA 16046 USA  
Telephone: 724-776-1020  
Fax: 724-776-1254  
E-mail: [quotes-ga@vag-group.com](mailto:quotes-ga@vag-group.com)

Please have the nameplate data available when ordering parts.

### WARRANTY:

The Warranty for GA Industries valves is included in our Terms and Conditions which can be found here: <https://gaindustries.com/terms>

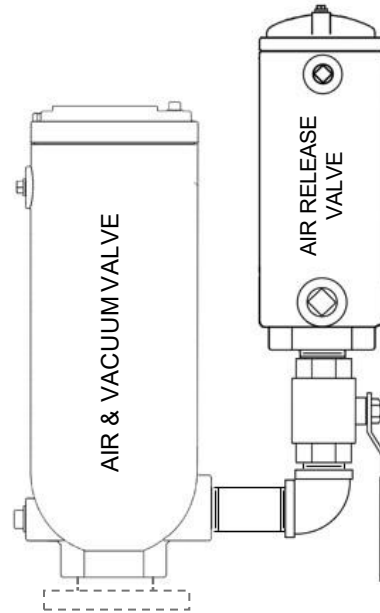

3" and 4" Figure 955  
(Optional 4" Figure 955-D Flanged)

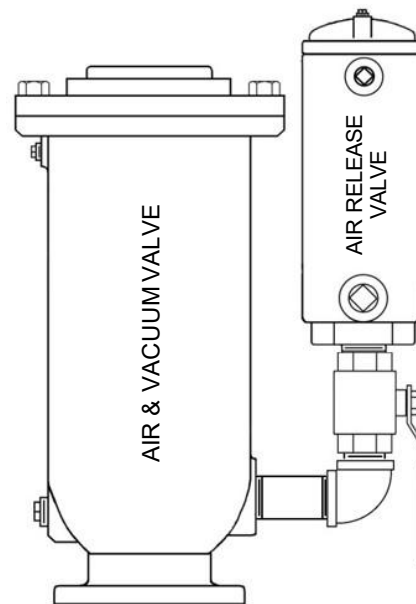

6" Figure 955-D



# Section 2

# INSTALLATION, OPERATION AND MAINTENANCE MANUAL

## FIGURE 935

### 3", 4" & 6" Drawings EAV-7132, EAV-7119 AIR & VACUUM VALVES FOR SEWAGE & WASTEWATER

#### TABLE OF CONTENTS

Introduction .....	2
Description of Operation .....	2
Receiving & Storage .....	2
Installation .....	2
Valve Construction .....	3
Preventive Maintenance .....	3
Trouble Shooting .....	3
Disassembly.....	3, 4
Reassembly .....	4
Backflushing Instructions .....	5
Order Replacement Parts .....	5
Warranty .....	5
Figure 942 Drawing/Parts List .....	6



**234 Clay Avenue • Mars, PA 16046 USA**  
**Telephone (724) 776-1020 • Fax (724) 776-1254**  
**E-mail: [info-ga@vag-group.com](mailto:info-ga@vag-group.com)**



**WARNING: Cancer and Reproductive Harm – [www.Prop65Warnings.ca.gov](http://www.Prop65Warnings.ca.gov)**

# INSTALLATION, OPERATION and MAINTENANCE

## Figure 935 Sewage Air & Vacuum Valves

### INTRODUCTION

This manual will provide the information to properly install, operate and maintain the valve to ensure a long service life. The GA Industries Figure 935 Air & Vacuum Valve is ruggedly constructed to provide years of trouble-free operation with minimal maintenance.

#### CAUTION

The valve is NOT recommended for use with toxic fluids, fuels or fluids containing hazardous gases

#### CAUTION

The valve will not function if used at a pressure higher than the maximum working pressure indicated on the nameplate.

The Shop Order (SO) Number, Figure Number, size and pressure rating are stamped on a nameplate attached to the valve. Please refer to the SO number when ordering parts.

### DESCRIPTION OF OPERATION

The Figure 935 Air & Vacuum Valve is designed to vent air through its large orifice as the system is being filled with liquid and close tight when the system is full and pressurized. The valve automatically opens to admit air through the large orifice during draining or when the internal pressure falls below atmospheric.

These valves are usually installed at high points in the system where air tends to collect and vacuum conditions initially form during draining. When empty of liquid, the valve is open allowing air to be vented ahead of incoming liquid. The float rises when water enters the valve and closes the orifice. As air is released

Should the pressure inside the valve fall below atmospheric both the large and small orifices open to allow air to be drawn into the system to alleviate vacuum conditions.

### RECEIVING AND STORAGE

Inspect the valve upon receipt for damage during shipment. Carefully unload all valves to the ground without dropping.

The valves should remain in a clean, dry and weather protected area until installed. For long term storage (greater than 6 months) the rubber surfaces of the seat should be coated with a non-toxic lubricant such as "SuperLube" made by Synco Chemical. Do not expose the rubber parts to sunlight or ozone.

### INSTALLATION

Sizes 3" and 4" Figure 935 can be supplied with an NPT or Class 125 pipeline connection; the 6" has Class 125 flanged pipeline connection.

Consult the drawings of record to verify the configuration supplied and installed.

The valve must be installed in an upright vertical orientation, normally at a high point in the system.

If installed outdoors, below ground in a vault or in an unheated area, adequate freeze protection must be provided.

An isolating valve should be installed between the valve and the pipeline or system to facilitate maintenance (included with backflushing attachments).

Carefully screw threaded end valves onto pipe nipple using compatible thread sealant. Tighten valve using wrench flats. DO NOT OVERTIGHTEN.

Flat-faced flanged valves should be mated with flat-faced flanges and full-face gaskets. If ring gaskets are used the bolt material shall be ASTM A307 Grade B (or equivalent). Higher strength bolting should only be used with full-face gaskets.

Lower heavy valves over the mating flange using slings or chains around the valve body. Lubricate the bolts or studs and insert around flange. Lightly tighten bolts until gaps are eliminated. Torque bolts in an alternating pattern in graduated steps. If leakage occurs wait 24 hours and re-torque the bolts but do not compress the gasket more than 50% or exceed bolt maximum torque rating.

### VALVE CONSTRUCTION

The standard Figure 935 Sewage Air & Vacuum Valve has a cast iron body, 316 stainless steel float, plug, seat and linkage mechanism and a Buna-N rubber seat. It has a working pressure range of 10 to 200 PSI. Optional materials can be provided for higher working pressures. Refer to the List of Materials submitted for the order if non-standard materials were provided.

Refer to Page 6 for details of construction and parts location.

The valve has an inlet connection at the bottom where the valve attaches to the system and an outlet connection at the top through which air exits and enters the valve.

#### WARNING

Removing the valve from the line or disassembling the valve while there is pressure in the valve body may result in injury or damage to the valve

### PREVENTIVE MAINTENANCE

Figure 935 Sewage Air & Vacuum Valves require no scheduled lubrication or adjustment.

A periodic visual inspection should be performed to ensure the outlet piping is not obstructed and to verify there is no fluid leakage.

Depending on the nature of the fluid, sewage air valves may become clogged with sediment or grease and require periodic cleaning. To facilitate such cleaning GA Industries air valves with an "F" at the end of the Figure Number (e.g., 935F) were supplied with "backflushing attachments." Refer to the backflushing instructions on Page 4 of this manual for additional information.

### TESTING

Valve operation can be easily tested. Close the inlet isolation valve and remove or loosen the pipe plug nearest the inlet to drain the water

from the valve. The float should drop as the water leaves the valve. NOTE: A manual valve can be installed in place of the pipe plug to facilitate testing (valves are included with backflushing attachments).

Replace or tighten the pipe plug and slowly open the inlet isolating valve. After expelling air, the valve should close and seal tightly.

### TROUBLESHOOTING

- Valve Does Not Close / Fluid Leakage  
Verify there is at least 10 PSI at the valve inlet for tight sealing

Verify debris has not collected on the seat preventing tight closure

Verify rubber seating surfaces are not damaged

Verify float has buoyancy

Verify linkage mechanism operates freely without binding or sticking

- Valve Does Not Open  
Verify debris in the valve is not preventing the float from freely falling when fluid is drained from valve

Verify linkage mechanism operates freely without binding or sticking

### DISASSEMBLY

While small valves may be more easily serviced by removing it from the line, all valves can be serviced while the body remains connected to the pipeline. A skilled technician with proper tools should perform all work. No special tools are required.

Disassemble the valve only as far as needed to replace damaged or worn parts.

First ensure there is no pressure within the valve. Refer to Pages 5 and 6 for parts location and identification.

Remove the cover bolts (9) and lift off cover (2) with float and linkage attached. It may be necessary to pry the cover off. Be careful not to damage or lose the cover O-ring (6).

Remove the spring pin (15) to free the Universal Coupling (13) from the connector (11). Remove

the cage bolts (23) and lift cage from cover. Unscrew the seat (4) from the cage (3) and remove the plug (5) and bushing (12). Note: Bushing only used in 6" valves or smaller valves with ductile iron cage. Remove the cage O-ring (7) and renewable seat (8) from the seat (4).

If necessary, remove upper (10) plug extensions from the plug (5). The extension is secured to the plug with Loctite so it may be necessary to apply heat to remove them.

Remove spring pins (15) from universal coupling freeing it from the float rod (14).

The float ball (20) is removed by loosening the hex nut (24) and unscrewing the float ball (20) by hand being careful not to lose the lock washer (16). Note: the hex nut and lock washer is not used on the 6" size valve. It may be necessary to apply some heat to unscrew the float from the float rod.

Remove the float hood (21) by removing the cap screw (22) and lock washer (16).

Inspect all parts for wear and damage. Minor scratches and dents in the float are normal. Replace the float if water is detected inside of it. Replace damaged parts.

### REASSEMBLY

Clean all parts especially seating and sealing surfaces before reassembling valve. Worn parts should be replaced during re-assembly.

Apply Loctite 263 threads on the upper extension (23) and the connector (11). Tightly screw the upper extension into the stem on the concave side of the plug (5) and the connector (11) into the stem on the opposite end.

Install bushing (12) and plug (5) in seat (4), lubricate and install renewable seat (8) in seat (4). Install plug (5) with upper extension and connector attached into bushing. Screw seat (4) into cage ensuring renewable seat remains in place. Install cage O-ring (7), position cage on cover and install cage bolts (27) and tighten.

Install spring pins (15) in universal coupling (13) to connect it to float rod (14) and connector (11).

Install hex nut (24) and lock washer (16) on end of float rod (not required on 6" valve) and apply

Loctite 263 to threads. Screw float ball (20) onto float rod (14) and tighten.

Apply Loctite 380 to float cap screw (22) and install lock washer (16) and float hood (21) onto bottom of float (20).

Verify plug and attached float and linkage freely falls away from seat when allowed to drop.

Lubricate and install cover O-ring (6) in cover and place on top of valve body (1) being careful O-ring remains in place. Install cover bolts (9) and tighten in a cross over pattern.

Re-install on pipeline slowly introduce pressure and ensure valve closes tightly.

### BACKFLUSHING INSTRUCTIONS

Follow all local cross-connection and safety codes and regulations!

To determine if a GA Industries sewage air valve needs cleaning or backflushing:

- Close the inlet isolating valve then slowly open the 1/2" flushing ball valve (if installed) or slowly remove the pipe plug at the top of air valve to relieve internal pressure.
- Open the 1" blow off ball valve (if installed) or remove the pipe plug near the bottom. Liquid should freely drain from the valve body. If it does not, then the valve is likely in need of cleaning or backflushing.

To clean a GA Industries sewage air release valve equipped with backflushing attachments:

- Close the inlet isolating valve and then slowly open the 1/2" flushing valve to relieve internal pressure.
- Open the 1" blow off valve
- Connect the 1/2" flushing valve to a pressurized source of clean water using the rubber hose provided with the backflushing attachments.
- Introduce flushing water until liquid runs freely from the blow off valve.
- Shut off and disconnect the supply of clean water and close the blow off and flushing valves.
- Slowly open the inlet isolating valve. The air release valve should exhaust air and then close tightly

## REPLACEMENT PARTS

Genuine replacement parts are available from your local VAG/GA Industries representative or from the factory:

VAG USA, LLC  
 234 Clay Avenue  
 Mars, PA 16046 USA  
 Telephone: 724-776-1020  
 Fax: 724-776-1254  
 E-mail: [quotes-ga@vag-group.com](mailto:quotes-ga@vag-group.com)

Please have the nameplate data available when ordering parts

## REPAIR KITS

3" Soft Goods Kit A935-3, Part Number 2-80-11000-020  
 4" Soft Goods Kit A935-4, Part Number 2-80-11000-021  
 6" Soft Goods Kit A935-6, Part Number 2-80-11000-022

Soft Goods Kit contains Items 6, 7 and 8

Other parts are ordered individually.

## WARRANTY

The Warranty for GA Industries valves is included in our Terms and Conditions which can be found here: <https://gaindustries.com/terms>

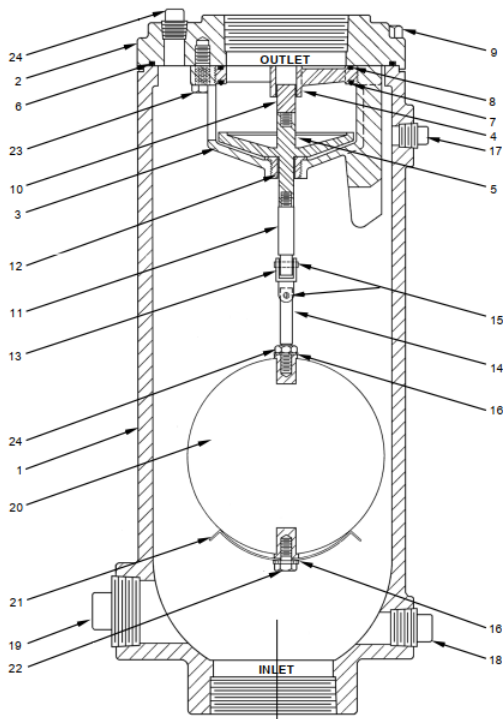

3" and 4" Figure 935

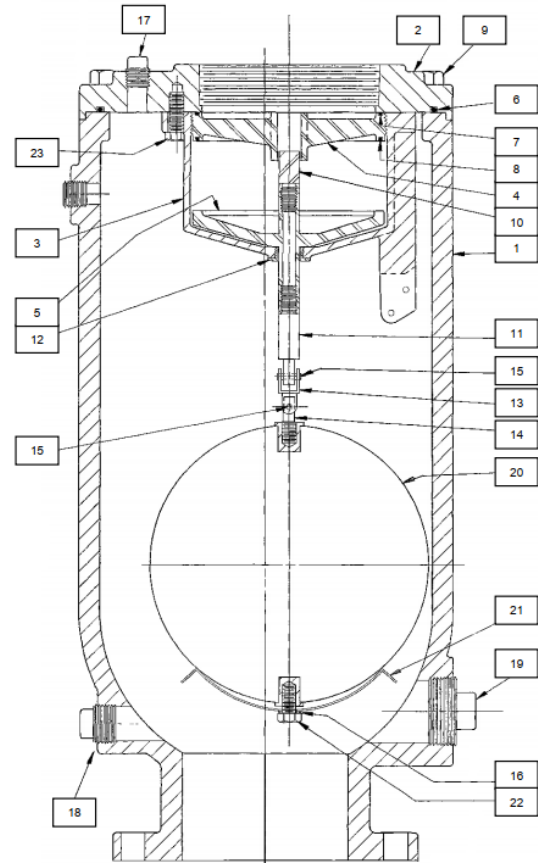

6" Figure 935

### PARTS LIST

Item	Description	Item	Description
1.	Body	13.	Universal Coupling
2.	Cover	14.	Float Rod
3.	Cage	15.	Spring Pin
4.	Seat	16.	Lock Washer
5.	Plug	17.	½" Pipe Plug
6.	Cover O-ring	18.	1" Pipe Plug
7.	Renewable Seat	19.	2" Pipe Plug
8.	Cage O-ring	20.	Float Ball
9.	Cover Bolt	21.	Float Hood
10.	Upper Plug Extension	22.	Float Cap Screw
11.	Connector	23.	Cage Bolt
12.	Bushing	24.	Hex Nut

This page intentionally left blank

This page intentionally left blank

# Section 3

# INSTALLATION, OPERATION AND MAINTENANCE MANUAL

## FIGURES 925 & 925SS

### AIR RELEASE VALVES FOR SEWAGE & WASTEWATER

#### TABLE OF CONTENTS

Introduction .....	2
Description of Operation .....	2
Receiving & Storage .....	2
Installation .....	2
Valve Construction .....	3
Preventive Maintenance .....	3
Testing/Trouble Shooting .....	3
Disassembly .....	3
Assembly .....	4
Backflushing Instructions .....	4
Order Replacement Parts .....	5
Repair Kits .....	5
Warranty .....	5
Figure 929 Drawing/Parts List .....	5



234 Clay Avenue • Mars, PA 16046 USA  
Telephone (724) 776-1020 • Fax (724) 776-1254  
E-mail: [info-ga@vag-group.com](mailto:info-ga@vag-group.com)



WARNING: Cancer and Reproductive Harm – [www.Prop65Warnings.ca.gov](http://www.Prop65Warnings.ca.gov)

# INSTALLATION, OPERATION and MAINTENANCE

## Figure 925 & 925SS Sewage Air Release Valves

### INTRODUCTION

This manual will provide the information to properly install, operate and maintain the valve to ensure a long service life. The Air Release Valve is ruggedly constructed to provide years of trouble-free operation with minimal maintenance.

#### CAUTION

The valve is NOT recommended for use with toxic fluids, fuels or fluids containing hazardous gases

#### CAUTION

The valve will not function if used at a pressure higher than the maximum working pressure indicated on the nameplate.

The Shop Order (SO) Number, Figure Number, size and pressure rating are stamped on a nameplate attached to the valve. Please refer to the SO number when ordering parts.

### DESCRIPTION OF OPERATION

The Figure 925 and 925SS Air Release Valves are designed to automatically vent air and sewage gas that has accumulated within the valve. These valves are usually installed at high points in the system where air tends to collect. The valves are "normally-open" and will vent air through its orifice at the top of the valve. The float rises when water enters the valve and closes the orifice. As air from the system accumulates in the valve it forces the water level down until the float drops and opens the venting orifice. As air is released the water level rises lifting the float and re-closing the valve.

This sequence occurs as often as necessary to release air that has collected in the valve.

### RECEIVING AND STORAGE

Inspect the valve upon receipt for damage during shipment. Carefully unload all valves to the ground without dropping.

The valves should remain in a clean, dry and weather protected area until installed. For long term storage (greater than 6 months) the rubber surfaces of the seat should be coated with a non-toxic lubricant such as "SuperLube" made by Synco Chemical. Do not expose the rubber parts to sunlight or ozone.

### INSTALLATION

Figure 925 and 925SS are standard with 2" or 3" NPT or 4" Class 125 flanged pipeline connection.

Consult the drawings of record to verify the configuration supplied and installed.

The valve must be installed in an upright vertical orientation, normally at a high point in the system.

If installed outdoors, below ground in a vault or in an unheated area, adequate freeze protection must be provided.

An isolating valve should be installed between the valve and the pipeline or system to facilitate maintenance (included with backflushing attachments).

Carefully screw threaded end valves onto pipe nipple using compatible thread sealant. Tighten valve using wrench flats. DO NOT OVERTIGHTEN.

Flat-faced flanged valves should be mated with flat-faced flanges and full-face gaskets. If ring gaskets are used the bolt material shall be ASTM A307 Grade B (or equivalent). Higher strength bolting should only be used with full-face gaskets.

Lower heavy valves over the mating flange using slings or chains around the valve body. Lubricate the bolts or studs and insert around flange. Lightly tighten bolts until gaps are eliminated. Torque bolts in an alternating pattern in graduated steps. If leakage occurs wait 24 hours and re-torque the bolts but do not compress the gasket more than 50% or exceed bolt maximum torque rating.

### VALVE CONSTRUCTION

The Figure 925 Sewage Air Release Valve has a cast iron body and cover while the Figure 925SS has a 316 stainless steel body and cover. Both have a 316SS stainless steel float and linkage mechanism and a rubber seat. Optional materials such as ductile iron body can be provided for higher working pressures. Refer to the List of Materials submitted for the order if non-standard materials were provided.

Refer to Page 5 for details of construction and parts location.

Figure 925 and 925SS have a 10 to 150 PSI working pressure range while the Figure 925L and 925SSL have a 10 to 75 PSI working pressure range.

The valve has an inlet connection at the bottom where the valve attaches to the system and a smaller outlet connection at the top through which air leaves the valve.

#### WARNING

Removing the valve from the line or disassembling the valve while there is pressure in the valve body may result in injury or damage to the valve

### PREVENTIVE MAINTENANCE

These sewage air release valves require no scheduled lubrication or adjustment.

A periodic visual inspection should be performed to ensure the outlet piping is not obstructed and to verify there is no fluid leakage.

Depending on the nature of the fluid, sewage air valves may become clogged with sediment or grease and require periodic cleaning. To facilitate such cleaning VAG/GA Industries air valves with an "F" at the end of the Figure Number (e.g., 925F, 925SSLF) were supplied with "backflushing attachments." Refer to the

backflushing instructions on Page 4 of this manual for additional information.

### TESTING

Valve operation can be easily tested. Close the inlet isolation valve and remove or loosen the pipe plug nearest the inlet to drain the water from the valve. The float should drop as the water leaves the valve. NOTE: A manual valve can be installed in place of the pipe plug to facilitate testing (valves are included with backflushing attachments).

Replace or tighten the pipe plug and slowly open the inlet isolating valve. After expelling air, the valve should close and seal tightly.

### TROUBLESHOOTING

- Valve Does Not Close / Fluid Leakage  
Verify debris has not collected on the seat preventing tight closure

Verify rubber orifice button and/or orifice seating surfaces are not damaged

Verify float has buoyancy

Verify linkage mechanism operates freely without binding or sticking

Verify the pressure at the valve inlet is at least 10 PSI

- Valve Does Not Open  
Verify debris in the valve is not preventing the float from freely falling when fluid is drained from valve

Verify linkage mechanism operates freely without binding or sticking

Verify the pressure at the valve inlet does not exceed the valve's maximum working pressure

### DISASSEMBLY

While small valves may be more easily serviced by removing it from the line, all valves can be serviced while the body remains connected to the pipeline. A skilled technician with proper tools should perform all work. No special tools are required.

Disassemble the valve only as far as needed to replace damaged or worn parts.

First ensure there is no pressure within the valve. Remove the cover bolts (16) and lift off cover (2) with float and linkage attached. It may be necessary to pry the cover off. Be careful not to damage or lose the O-ring (10) unless it's being replaced.

Remove the two spring pins (13) connecting the lever arm (11) and float arm (12) to the bracket (3). The float and linkage will be free from the cover.

Remove the spring pins (13) connecting the valve links (14) to the float arm (12). Remove the spring pin (13) from the pivot link (15) and the hex nut (8) and lock washer (9). Unscrew the float rod (21) from the float ball (20). It may be necessary to apply some heat to these threaded connections as they are secured with Loctite.

Remove the hex nut (8) and lock washer (9) and unscrew the orifice button (7) from the lever arm (11).

Remove the bracket screw (5) to remove the leverage bracket (3). Using a hex socket remove the orifice (4) from the cover.

Inspect all parts for wear and damage. Minor scratches and dents in the float are normal. Some floats may contain sand for added weight but if water is detected replace the float. Carefully clean the orifice of scale. Replace damaged parts.

## REASSEMBLY

Clean all parts especially seating and sealing surfaces before reassembling valve. Worn parts should be replaced during re-assembly.

Apply Loctite® PST thread sealant to orifice (4) and thread into cover. Torque to 22 ft-lbs (maximum).

Install bracket (3), bracket screws (5) and lock washers (6) and tighten.

Thread orifice button (7) all the way into lever arm (11) and install hex nut (8) and lock washer (9) but do not tighten. Connect the lever arm (11) and float arm (12) to the bracket (3) using two spring pins (13).

Adjust the orifice button (7) so that the end of the lever arm (11) nearest the orifice button is about 1/16" (1.6mm) farther from the cover than

the opposite end when the orifice button (7) is gently resting on the orifice (4). Secure by tightening hex nut (8).

Install valve links (14) and spring pins (13) to connect the float arm (12) to the lever arm (11).

Apply Loctite 263 to one end of float rod threads and install lock washer (9) and float rod (21) into float ball (20) and tighten. Apply Loctite 263 to the threads on the other end of float rod. Install pivot link (15), lock washer (9) and hex nut (8) on opposite end of float rod (19) and tighten. Attach pivot link (15) to float arm (12) using spring pin (13).

Verify free movement of linkage mechanism and that the orifice button (7) presses against the orifice (4) when the float rises and pulls away when allowed to fall.

Lubricate and place O-ring (10) in cover (2) and carefully place cover (2) on body (1) ensuring O-ring is retained. Install the cover bolts (16) and tighten in an alternating pattern.

Carefully introduce pressure and check for leaks.

## BACKFLUSHING INSTRUCTIONS

Follow all local cross-connection and safety codes and regulations!
---

To determine if a GA Industries sewage air valve needs cleaning or backflushing:

- Close the inlet isolating valve then slowly open the ½" flushing ball valve (if installed) or slowly remove the pipe plug at the top of air valve to relieve internal pressure.
- Open the 1" blow off ball valve (if installed) or remove the pipe plug near the bottom. Liquid should freely drain from the valve body. If it does not, then the valve is likely in need of cleaning or backflushing.

To clean a GA Industries air valve equipped with backflushing attachments:

- Close the inlet isolating valve and then slowly open the ½" flushing valve to relieve internal pressure.
- Open the 1" blow off valve
- Connect the ½" flushing valve to a pressurized source of clean water using

the rubber hose provided with the backflushing attachments.

- Introduce flushing water until liquid runs freely from the blow off valve.
- Shut off and disconnect the supply of clean water and close the blow off and flushing valves.
- Slowly open the inlet isolating valve. The air release valve should exhaust air and then close tightly

### REPLACEMENT PARTS

Genuine replacement parts are available from your local VAG/GA Industries representative or from the factory:

VAG USA, LLC  
 234 Clay Avenue  
 Mars, PA 16046 USA  
 Telephone: 724-776-1020  
 Fax: 724-776-1254  
 E-mail: [quotes-ga@vag-group.com](mailto:quotes-ga@vag-group.com)

Please have the nameplate data available when ordering parts.

### REPAIR KITS

Soft Goods Kit A925 (Part Number 2-80-11000-008) contains Items 7, 8, 9 and 10

Linkage Kit AL925 (Part Number 2-80-11000-084) contains Items 3, 5, 6, 11, 12, 13, 14, 15 and 20

### WARRANTY

The Warranty for GA Industries valves is included in our Terms and Conditions which can be found here: <https://gaindustries.com/terms>

**VAG USA, LLC**  
 234 Clay Avenue • Mars, PA 16046 USA  
 Phone: 724-776-1020 • Fax: 724-776-1020  
[info-ga@vag-group.com](mailto:info-ga@vag-group.com)  
[www.gaindustries.com](http://www.gaindustries.com)

\* Figure 925SS standard 316SS  
 \*\* Figure 925SS standard 316SS cover bolts, optional Figure 925

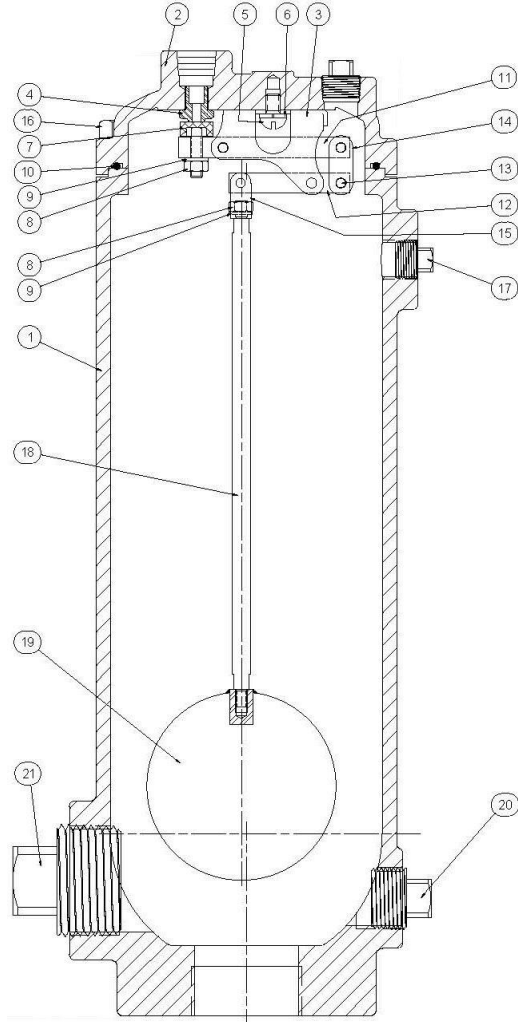

Item	Description	Standard Material
1	Body	Cast Iron or 316SS*
2	Cover	Cast Iron or 316SS*
3	Leverage Bracket	316 Stainless Steel
4	Orifice	316 Stainless Steel
5	Bracket Screw	304 Stainless Steel
6	Lock Washer	410 Stainless Steel
7	Orifice Button	Buna-N Rubber/SS
8	Hex Nut	304 Stainless Steel
9	Lock Washer	410 Stainless Steel
10	O-Ring	Buna-N Rubber
11	Lever Arm	316 Stainless Steel
12	Float Arm	316 Stainless Steel
13	Spring Pin	316 Stainless Steel
14	Valve Link	316 Stainless Steel
15	Pivot Link	316 Stainless Steel
16	Cover Bolt	Steel or 316SS**
17	1/2" Pipe Plug	Steel or 316 SS*
18	1" Pipe Plug	Cast Iron or 316SS*
19	2" Pipe Plug	Cast Iron or 316SS*
20	Float Ball	316 Stainless Steel
21	Float Rod	316 Stainless Steel



# Section 2

# INSTALLATION, OPERATION AND MAINTENANCE MANUAL

## FIGURE 935

### 3", 4" & 6" Drawings EAV-7132, EAV-7119 AIR & VACUUM VALVES FOR SEWAGE & WASTEWATER

#### TABLE OF CONTENTS

Introduction .....	2
Description of Operation .....	2
Receiving & Storage .....	2
Installation .....	2
Valve Construction .....	3
Preventive Maintenance .....	3
Trouble Shooting .....	3
Disassembly.....	3, 4
Reassembly .....	4
Backflushing Instructions .....	5
Order Replacement Parts .....	5
Warranty .....	5
Figure 942 Drawing/Parts List .....	6



**234 Clay Avenue • Mars, PA 16046 USA**  
**Telephone (724) 776-1020 • Fax (724) 776-1254**  
**E-mail: [info-ga@vag-group.com](mailto:info-ga@vag-group.com)**



**WARNING: Cancer and Reproductive Harm – [www.Prop65Warnings.ca.gov](http://www.Prop65Warnings.ca.gov)**

# INSTALLATION, OPERATION and MAINTENANCE

## Figure 935 Sewage Air & Vacuum Valves

### INTRODUCTION

This manual will provide the information to properly install, operate and maintain the valve to ensure a long service life. The GA Industries Figure 935 Air & Vacuum Valve is ruggedly constructed to provide years of trouble-free operation with minimal maintenance.

#### CAUTION

The valve is NOT recommended for use with toxic fluids, fuels or fluids containing hazardous gases

#### CAUTION

The valve will not function if used at a pressure higher than the maximum working pressure indicated on the nameplate.

The Shop Order (SO) Number, Figure Number, size and pressure rating are stamped on a nameplate attached to the valve. Please refer to the SO number when ordering parts.

### DESCRIPTION OF OPERATION

The Figure 935 Air & Vacuum Valve is designed to vent air through its large orifice as the system is being filled with liquid and close tight when the system is full and pressurized. The valve automatically opens to admit air through the large orifice during draining or when the internal pressure falls below atmospheric.

These valves are usually installed at high points in the system where air tends to collect and vacuum conditions initially form during draining. When empty of liquid, the valve is open allowing air to be vented ahead of incoming liquid. The float rises when water enters the valve and closes the orifice. As air is released

Should the pressure inside the valve fall below atmospheric both the large and small orifices open to allow air to be drawn into the system to alleviate vacuum conditions.

### RECEIVING AND STORAGE

Inspect the valve upon receipt for damage during shipment. Carefully unload all valves to the ground without dropping.

The valves should remain in a clean, dry and weather protected area until installed. For long term storage (greater than 6 months) the rubber surfaces of the seat should be coated with a non-toxic lubricant such as "SuperLube" made by Synco Chemical. Do not expose the rubber parts to sunlight or ozone.

### INSTALLATION

Sizes 3" and 4" Figure 935 can be supplied with an NPT or Class 125 pipeline connection; the 6" has Class 125 flanged pipeline connection.

Consult the drawings of record to verify the configuration supplied and installed.

The valve must be installed in an upright vertical orientation, normally at a high point in the system.

If installed outdoors, below ground in a vault or in an unheated area, adequate freeze protection must be provided.

An isolating valve should be installed between the valve and the pipeline or system to facilitate maintenance (included with backflushing attachments).

Carefully screw threaded end valves onto pipe nipple using compatible thread sealant. Tighten valve using wrench flats. DO NOT OVERTIGHTEN.

Flat-faced flanged valves should be mated with flat-faced flanges and full-face gaskets. If ring gaskets are used the bolt material shall be ASTM A307 Grade B (or equivalent). Higher strength bolting should only be used with full-face gaskets.

Lower heavy valves over the mating flange using slings or chains around the valve body. Lubricate the bolts or studs and insert around flange. Lightly tighten bolts until gaps are eliminated. Torque bolts in an alternating pattern in graduated steps. If leakage occurs wait 24 hours and re-torque the bolts but do not compress the gasket more than 50% or exceed bolt maximum torque rating.

### VALVE CONSTRUCTION

The standard Figure 935 Sewage Air & Vacuum Valve has a cast iron body, 316 stainless steel float, plug, seat and linkage mechanism and a Buna-N rubber seat. It has a working pressure range of 10 to 200 PSI. Optional materials can be provided for higher working pressures. Refer to the List of Materials submitted for the order if non-standard materials were provided.

Refer to Page 6 for details of construction and parts location.

The valve has an inlet connection at the bottom where the valve attaches to the system and an outlet connection at the top through which air exits and enters the valve.

#### WARNING

Removing the valve from the line or disassembling the valve while there is pressure in the valve body may result in injury or damage to the valve

### PREVENTIVE MAINTENANCE

Figure 935 Sewage Air & Vacuum Valves require no scheduled lubrication or adjustment.

A periodic visual inspection should be performed to ensure the outlet piping is not obstructed and to verify there is no fluid leakage.

Depending on the nature of the fluid, sewage air valves may become clogged with sediment or grease and require periodic cleaning. To facilitate such cleaning GA Industries air valves with an "F" at the end of the Figure Number (e.g., 935F) were supplied with "backflushing attachments." Refer to the backflushing instructions on Page 4 of this manual for additional information.

### TESTING

Valve operation can be easily tested. Close the inlet isolation valve and remove or loosen the pipe plug nearest the inlet to drain the water

from the valve. The float should drop as the water leaves the valve. NOTE: A manual valve can be installed in place of the pipe plug to facilitate testing (valves are included with backflushing attachments).

Replace or tighten the pipe plug and slowly open the inlet isolating valve. After expelling air, the valve should close and seal tightly.

### TROUBLESHOOTING

- Valve Does Not Close / Fluid Leakage  
Verify there is at least 10 PSI at the valve inlet for tight sealing

Verify debris has not collected on the seat preventing tight closure

Verify rubber seating surfaces are not damaged

Verify float has buoyancy

Verify linkage mechanism operates freely without binding or sticking

- Valve Does Not Open  
Verify debris in the valve is not preventing the float from freely falling when fluid is drained from valve

Verify linkage mechanism operates freely without binding or sticking

### DISASSEMBLY

While small valves may be more easily serviced by removing it from the line, all valves can be serviced while the body remains connected to the pipeline. A skilled technician with proper tools should perform all work. No special tools are required.

Disassemble the valve only as far as needed to replace damaged or worn parts.

First ensure there is no pressure within the valve. Refer to Pages 5 and 6 for parts location and identification.

Remove the cover bolts (9) and lift off cover (2) with float and linkage attached. It may be necessary to pry the cover off. Be careful not to damage or lose the cover O-ring (6).

Remove the spring pin (15) to free the Universal Coupling (13) from the connector (11). Remove

the cage bolts (23) and lift cage from cover. Unscrew the seat (4) from the cage (3) and remove the plug (5) and bushing (12). Note: Bushing only used in 6" valves or smaller valves with ductile iron cage. Remove the cage O-ring (7) and renewable seat (8) from the seat (4).

If necessary, remove upper (10) plug extensions from the plug (5). The extension is secured to the plug with Loctite so it may be necessary to apply heat to remove them.

Remove spring pins (15) from universal coupling freeing it from the float rod (14).

The float ball (20) is removed by loosening the hex nut (24) and unscrewing the float ball (20) by hand being careful not to lose the lock washer (16). Note: the hex nut and lock washer is not used on the 6" size valve. It may be necessary to apply some heat to unscrew the float from the float rod.

Remove the float hood (21) by removing the cap screw (22) and lock washer (16).

Inspect all parts for wear and damage. Minor scratches and dents in the float are normal. Replace the float if water is detected inside of it. Replace damaged parts.

### REASSEMBLY

Clean all parts especially seating and sealing surfaces before reassembling valve. Worn parts should be replaced during re-assembly.

Apply Loctite 263 threads on the upper extension (23) and the connector (11). Tightly screw the upper extension into the stem on the concave side of the plug (5) and the connector (11) into the stem on the opposite end.

Install bushing (12) and plug (5) in seat (4), lubricate and install renewable seat (8) in seat (4). Install plug (5) with upper extension and connector attached into bushing. Screw seat (4) into cage ensuring renewable seat remains in place. Install cage O-ring (7), position cage on cover and install cage bolts (27) and tighten.

Install spring pins (15) in universal coupling (13) to connect it to float rod (14) and connector (11).

Install hex nut (24) and lock washer (16) on end of float rod (not required on 6" valve) and apply

Loctite 263 to threads. Screw float ball (20) onto float rod (14) and tighten.

Apply Loctite 380 to float cap screw (22) and install lock washer (16) and float hood (21) onto bottom of float (20).

Verify plug and attached float and linkage freely falls away from seat when allowed to drop.

Lubricate and install cover O-ring (6) in cover and place on top of valve body (1) being careful O-ring remains in place. Install cover bolts (9) and tighten in a cross over pattern.

Re-install on pipeline slowly introduce pressure and ensure valve closes tightly.

### BACKFLUSHING INSTRUCTIONS

Follow all local cross-connection and safety codes and regulations!
---

To determine if a GA Industries sewage air valve needs cleaning or backflushing:

- Close the inlet isolating valve then slowly open the 1/2" flushing ball valve (if installed) or slowly remove the pipe plug at the top of air valve to relieve internal pressure.
- Open the 1" blow off ball valve (if installed) or remove the pipe plug near the bottom. Liquid should freely drain from the valve body. If it does not, then the valve is likely in need of cleaning or backflushing.

To clean a GA Industries sewage air release valve equipped with backflushing attachments:

- Close the inlet isolating valve and then slowly open the 1/2" flushing valve to relieve internal pressure.
- Open the 1" blow off valve
- Connect the 1/2" flushing valve to a pressurized source of clean water using the rubber hose provided with the backflushing attachments.
- Introduce flushing water until liquid runs freely from the blow off valve.
- Shut off and disconnect the supply of clean water and close the blow off and flushing valves.
- Slowly open the inlet isolating valve. The air release valve should exhaust air and then close tightly

## REPLACEMENT PARTS

Genuine replacement parts are available from your local VAG/GA Industries representative or from the factory:

VAG USA, LLC  
 234 Clay Avenue  
 Mars, PA 16046 USA  
 Telephone: 724-776-1020  
 Fax: 724-776-1254  
 E-mail: [quotes-ga@vag-group.com](mailto:quotes-ga@vag-group.com)

Please have the nameplate data available when ordering parts

## REPAIR KITS

3" Soft Goods Kit A935-3, Part Number 2-80-11000-020  
 4" Soft Goods Kit A935-4, Part Number 2-80-11000-021  
 6" Soft Goods Kit A935-6, Part Number 2-80-11000-022

Soft Goods Kit contains Items 6, 7 and 8

Other parts are ordered individually.

## WARRANTY

The Warranty for GA Industries valves is included in our Terms and Conditions which can be found here: <https://gaindustries.com/terms>

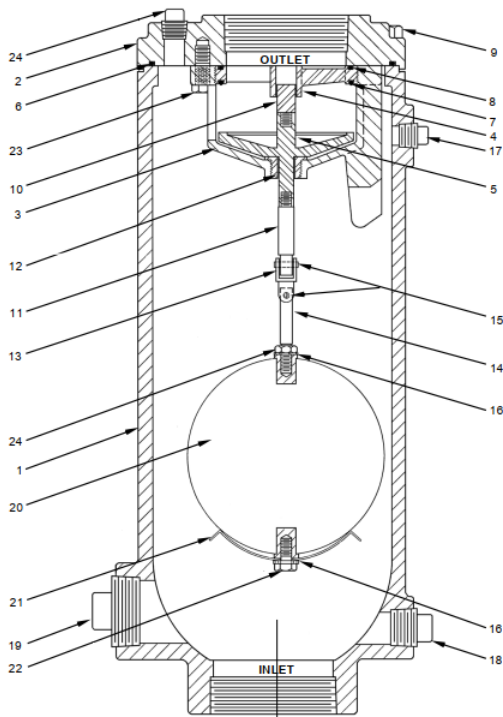

3" and 4" Figure 935

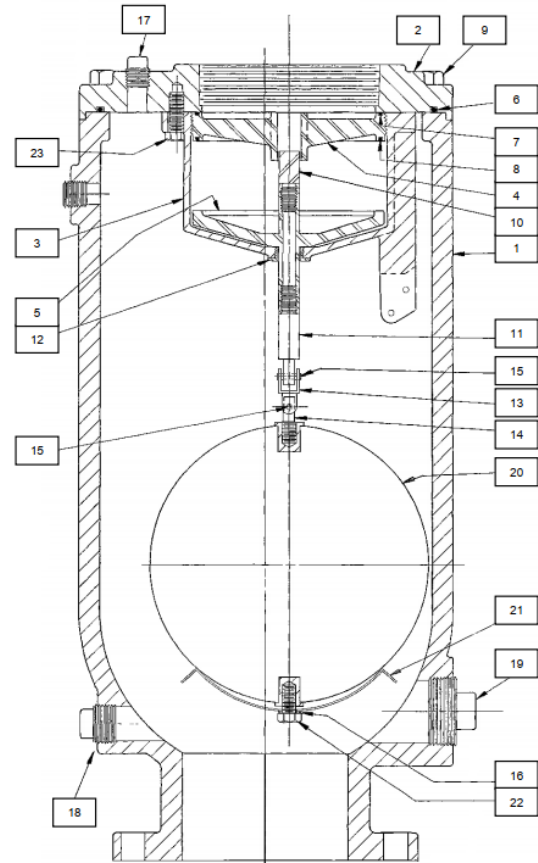

6" Figure 935

### PARTS LIST

Item	Description	Item	Description
1.	Body	13.	Universal Coupling
2.	Cover	14.	Float Rod
3.	Cage	15.	Spring Pin
4.	Seat	16.	Lock Washer
5.	Plug	17.	½" Pipe Plug
6.	Cover O-ring	18.	1" Pipe Plug
7.	Renewable Seat	19.	2" Pipe Plug
8.	Cage O-ring	20.	Float Ball
9.	Cover Bolt	21.	Float Hood
10.	Upper Plug Extension	22.	Float Cap Screw
11.	Connector	23.	Cage Bolt
12.	Bushing	24.	Hex Nut

This page intentionally left blank

This page intentionally left blank

# Section 3

# INSTALLATION, OPERATION AND MAINTENANCE MANUAL

## FIGURES 925 & 925SS

### AIR RELEASE VALVES FOR SEWAGE & WASTEWATER

#### TABLE OF CONTENTS

Introduction .....	2
Description of Operation .....	2
Receiving & Storage .....	2
Installation .....	2
Valve Construction .....	3
Preventive Maintenance .....	3
Testing/Trouble Shooting .....	3
Disassembly .....	3
Assembly .....	4
Backflushing Instructions .....	4
Order Replacement Parts .....	5
Repair Kits .....	5
Warranty .....	5
Figure 929 Drawing/Parts List .....	5



234 Clay Avenue • Mars, PA 16046 USA  
Telephone (724) 776-1020 • Fax (724) 776-1254  
E-mail: [info-ga@vag-group.com](mailto:info-ga@vag-group.com)



WARNING: Cancer and Reproductive Harm – [www.Prop65Warnings.ca.gov](http://www.Prop65Warnings.ca.gov)

# INSTALLATION, OPERATION and MAINTENANCE

## Figure 925 & 925SS Sewage Air Release Valves

### INTRODUCTION

This manual will provide the information to properly install, operate and maintain the valve to ensure a long service life. The Air Release Valve is ruggedly constructed to provide years of trouble-free operation with minimal maintenance.

#### CAUTION

The valve is NOT recommended for use with toxic fluids, fuels or fluids containing hazardous gases

#### CAUTION

The valve will not function if used at a pressure higher than the maximum working pressure indicated on the nameplate.

The Shop Order (SO) Number, Figure Number, size and pressure rating are stamped on a nameplate attached to the valve. Please refer to the SO number when ordering parts.

### DESCRIPTION OF OPERATION

The Figure 925 and 925SS Air Release Valves are designed to automatically vent air and sewage gas that has accumulated within the valve. These valves are usually installed at high points in the system where air tends to collect. The valves are "normally-open" and will vent air through its orifice at the top of the valve. The float rises when water enters the valve and closes the orifice. As air from the system accumulates in the valve it forces the water level down until the float drops and opens the venting orifice. As air is released the water level rises lifting the float and re-closing the valve.

This sequence occurs as often as necessary to release air that has collected in the valve.

### RECEIVING AND STORAGE

Inspect the valve upon receipt for damage during shipment. Carefully unload all valves to the ground without dropping.

The valves should remain in a clean, dry and weather protected area until installed. For long term storage (greater than 6 months) the rubber surfaces of the seat should be coated with a non-toxic lubricant such as "SuperLube" made by Synco Chemical. Do not expose the rubber parts to sunlight or ozone.

### INSTALLATION

Figure 925 and 925SS are standard with 2" or 3" NPT or 4" Class 125 flanged pipeline connection.

Consult the drawings of record to verify the configuration supplied and installed.

The valve must be installed in an upright vertical orientation, normally at a high point in the system.

If installed outdoors, below ground in a vault or in an unheated area, adequate freeze protection must be provided.

An isolating valve should be installed between the valve and the pipeline or system to facilitate maintenance (included with backflushing attachments).

Carefully screw threaded end valves onto pipe nipple using compatible thread sealant. Tighten valve using wrench flats. DO NOT OVERTIGHTEN.

Flat-faced flanged valves should be mated with flat-faced flanges and full-face gaskets. If ring gaskets are used the bolt material shall be ASTM A307 Grade B (or equivalent). Higher strength bolting should only be used with full-face gaskets.

Lower heavy valves over the mating flange using slings or chains around the valve body. Lubricate the bolts or studs and insert around flange. Lightly tighten bolts until gaps are eliminated. Torque bolts in an alternating pattern in graduated steps. If leakage occurs wait 24 hours and re-torque the bolts but do not compress the gasket more than 50% or exceed bolt maximum torque rating.

### VALVE CONSTRUCTION

The Figure 925 Sewage Air Release Valve has a cast iron body and cover while the Figure 925SS has a 316 stainless steel body and cover. Both have a 316SS stainless steel float and linkage mechanism and a rubber seat. Optional materials such as ductile iron body can be provided for higher working pressures. Refer to the List of Materials submitted for the order if non-standard materials were provided.

Refer to Page 5 for details of construction and parts location.

Figure 925 and 925SS have a 10 to 150 PSI working pressure range while the Figure 925L and 925SSL have a 10 to 75 PSI working pressure range.

The valve has an inlet connection at the bottom where the valve attaches to the system and a smaller outlet connection at the top through which air leaves the valve.

#### WARNING

Removing the valve from the line or disassembling the valve while there is pressure in the valve body may result in injury or damage to the valve

### PREVENTIVE MAINTENANCE

These sewage air release valves require no scheduled lubrication or adjustment.

A periodic visual inspection should be performed to ensure the outlet piping is not obstructed and to verify there is no fluid leakage.

Depending on the nature of the fluid, sewage air valves may become clogged with sediment or grease and require periodic cleaning. To facilitate such cleaning VAG/GA Industries air valves with an "F" at the end of the Figure Number (e.g., 925F, 925SSLF) were supplied with "backflushing attachments." Refer to the

backflushing instructions on Page 4 of this manual for additional information.

### TESTING

Valve operation can be easily tested. Close the inlet isolation valve and remove or loosen the pipe plug nearest the inlet to drain the water from the valve. The float should drop as the water leaves the valve. NOTE: A manual valve can be installed in place of the pipe plug to facilitate testing (valves are included with backflushing attachments).

Replace or tighten the pipe plug and slowly open the inlet isolating valve. After expelling air, the valve should close and seal tightly.

### TROUBLESHOOTING

- Valve Does Not Close / Fluid Leakage  
Verify debris has not collected on the seat preventing tight closure

Verify rubber orifice button and/or orifice seating surfaces are not damaged

Verify float has buoyancy

Verify linkage mechanism operates freely without binding or sticking

Verify the pressure at the valve inlet is at least 10 PSI

- Valve Does Not Open  
Verify debris in the valve is not preventing the float from freely falling when fluid is drained from valve

Verify linkage mechanism operates freely without binding or sticking

Verify the pressure at the valve inlet does not exceed the valve's maximum working pressure

### DISASSEMBLY

While small valves may be more easily serviced by removing it from the line, all valves can be serviced while the body remains connected to the pipeline. A skilled technician with proper tools should perform all work. No special tools are required.

Disassemble the valve only as far as needed to replace damaged or worn parts.

First ensure there is no pressure within the valve. Remove the cover bolts (16) and lift off cover (2) with float and linkage attached. It may be necessary to pry the cover off. Be careful not to damage or lose the O-ring (10) unless it's being replaced.

Remove the two spring pins (13) connecting the lever arm (11) and float arm (12) to the bracket (3). The float and linkage will be free from the cover.

Remove the spring pins (13) connecting the valve links (14) to the float arm (12). Remove the spring pin (13) from the pivot link (15) and the hex nut (8) and lock washer (9). Unscrew the float rod (21) from the float ball (20). It may be necessary to apply some heat to these threaded connections as they are secured with Loctite.

Remove the hex nut (8) and lock washer (9) and unscrew the orifice button (7) from the lever arm (11).

Remove the bracket screw (5) to remove the leverage bracket (3). Using a hex socket remove the orifice (4) from the cover.

Inspect all parts for wear and damage. Minor scratches and dents in the float are normal. Some floats may contain sand for added weight but if water is detected replace the float. Carefully clean the orifice of scale. Replace damaged parts.

## REASSEMBLY

Clean all parts especially seating and sealing surfaces before reassembling valve. Worn parts should be replaced during re-assembly.

Apply Loctite® PST thread sealant to orifice (4) and thread into cover. Torque to 22 ft-lbs (maximum).

Install bracket (3), bracket screws (5) and lock washers (6) and tighten.

Thread orifice button (7) all the way into lever arm (11) and install hex nut (8) and lock washer (9) but do not tighten. Connect the lever arm (11) and float arm (12) to the bracket (3) using two spring pins (13).

Adjust the orifice button (7) so that the end of the lever arm (11) nearest the orifice button is about 1/16" (1.6mm) farther from the cover than

the opposite end when the orifice button (7) is gently resting on the orifice (4). Secure by tightening hex nut (8).

Install valve links (14) and spring pins (13) to connect the float arm (12) to the lever arm (11).

Apply Loctite 263 to one end of float rod threads and Install lock washer (9) and float rod (21) into float ball (20) and tighten. Apply Loctite 263 to the threads on the other end of float rod. Install pivot link (15), lock washer (9) and hex nut (8) on opposite end of float rod (19) and tighten. Attach pivot link (15) to float arm (12) using spring pin (13).

Verify free movement of linkage mechanism and that the orifice button (7) presses against the orifice (4) when the float rises and pulls away when allowed to fall.

Lubricate and place O-ring (10) in cover (2) and carefully place cover (2) on body (1) ensuring O-ring is retained. Install the cover bolts (16) and tighten in an alternating pattern.

Carefully introduce pressure and check for leaks.

## BACKFLUSHING INSTRUCTIONS

Follow all local cross-connection and safety codes and regulations!
---

To determine if a GA Industries sewage air valve needs cleaning or backflushing:

- Close the inlet isolating valve then slowly open the ½" flushing ball valve (if installed) or slowly remove the pipe plug at the top of air valve to relieve internal pressure.
- Open the 1" blow off ball valve (if installed) or remove the pipe plug near the bottom. Liquid should freely drain from the valve body. If it does not, then the valve is likely in need of cleaning or backflushing.

To clean a GA Industries air valve equipped with backflushing attachments:

- Close the inlet isolating valve and then slowly open the ½" flushing valve to relieve internal pressure.
- Open the 1" blow off valve
- Connect the ½" flushing valve to a pressurized source of clean water using

the rubber hose provided with the backflushing attachments.

- Introduce flushing water until liquid runs freely from the blow off valve.
- Shut off and disconnect the supply of clean water and close the blow off and flushing valves.
- Slowly open the inlet isolating valve. The air release valve should exhaust air and then close tightly

**REPLACEMENT PARTS**

Genuine replacement parts are available from your local VAG/GA Industries representative or from the factory:

VAG USA, LLC  
 234 Clay Avenue  
 Mars, PA 16046 USA  
 Telephone: 724-776-1020  
 Fax: 724-776-1254  
 E-mail: [quotes-ga@vag-group.com](mailto:quotes-ga@vag-group.com)

Please have the nameplate data available when ordering parts.

**REPAIR KITS**

Soft Goods Kit A925 (Part Number 2-80-11000-008) contains Items 7, 8, 9 and 10

Linkage Kit AL925 (Part Number 2-80-11000-084) contains Items 3, 5, 6, 11, 12, 13, 14, 15 and 20

**WARRANTY**

The Warranty for GA Industries valves is included in our Terms and Conditions which can be found here: <https://gaindustries.com/terms>

**VAG USA, LLC**  
 234 Clay Avenue • Mars, PA 16046 USA  
 Phone: 724-776-1020 • Fax: 724-776-1020  
[info-ga@vag-group.com](mailto:info-ga@vag-group.com)  
[www.gaindustries.com](http://www.gaindustries.com)

\* Figure 925SS standard 316SS  
 \*\* Figure 925SS standard 316SS cover bolts, optional Figure 925

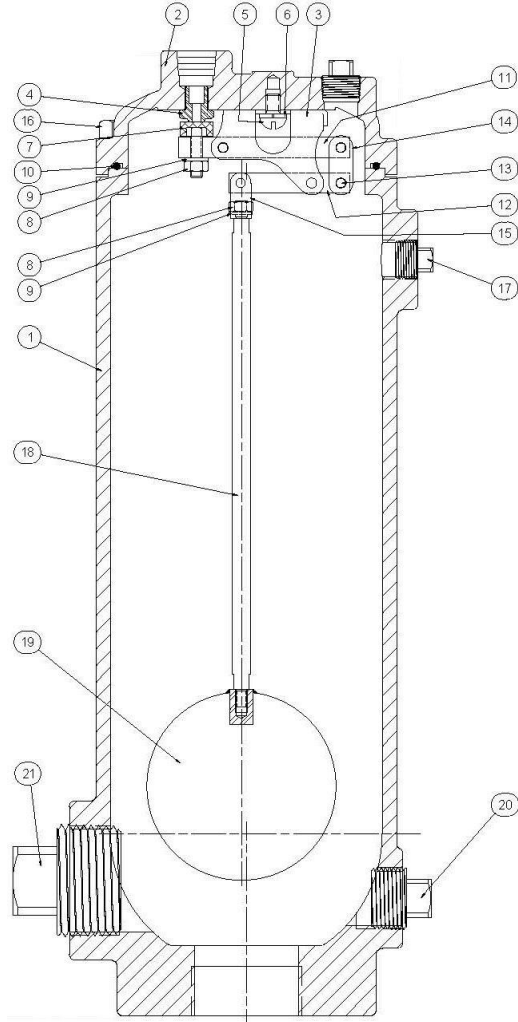

Item	Description	Standard Material
1	Body	Cast Iron or 316SS*
2	Cover	Cast Iron or 316SS*
3	Leverage Bracket	316 Stainless Steel
4	Orifice	316 Stainless Steel
5	Bracket Screw	304 Stainless Steel
6	Lock Washer	410 Stainless Steel
7	Orifice Button	Buna-N Rubber/SS
8	Hex Nut	304 Stainless Steel
9	Lock Washer	410 Stainless Steel
10	O-Ring	Buna-N Rubber
11	Lever Arm	316 Stainless Steel
12	Float Arm	316 Stainless Steel
13	Spring Pin	316 Stainless Steel
14	Valve Link	316 Stainless Steel
15	Pivot Link	316 Stainless Steel
16	Cover Bolt	Steel or 316SS**
17	1/2" Pipe Plug	Steel or 316 SS*
18	1" Pipe Plug	Cast Iron or 316SS*
19	2" Pipe Plug	Cast Iron or 316SS*
20	Float Ball	316 Stainless Steel
21	Float Rod	316 Stainless Steel

