

INSTALLATION, OPERATION AND MAINTENANCE MANUAL

6" to 12" Figure 983-D Combination Air Valve with Surge Check (Anti-Slam Device)

SECTION 1 – Figure 983-D Combination Air Valves with Surge Check
Instructions

SECTION 2 – 6" & 8" Figure 930 Air & Vacuum Valve Instructions

SECTION 3 – 10" & 12" Figure 930 Air & Vacuum Valve Instructions

SECTION 4 – Figure 920 Air Release Valve Instructions

SECTION 5 – Figure F284-D Surge Check Instructions



234 Clay Avenue • Mars, PA 16046 USA
Telephone (724) 776-1020 • Fax (724) 776-1254
E-mail: info-ga@vag-group.com

Manual Number 983.02-IOM-061226



WARNING: Cancer and Reproductive Harm – www.Prop65Warnings.ca.gov

Section 1

INSTALLATION, OPERATION AND MAINTENANCE MANUAL

6" to 12" Figure 983-D Combination Air Valve with Surge Check (Anti-Slam Device)

TABLE OF CONTENTS

Introduction.....	1
Description of Operation	1
Receiving & Storage.....	1
Installation.....	1
Start-Up.....	2
Preventative Maintenance	2
Testing	2
Trouble Shooting.....	2
Repair Instructions	2
Replacement Parts	2
Warranty.....	2
Assembly Drawing/Component Location ..	2



234 Clay Avenue • Mars, PA 16046 USA
Telephone (724) 776-1020 • Fax (724) 776-1254
E-mail: info-ga@vag-group.com

Manual Number IOM-983.02-061226



WARNING: Cancer and Reproductive Harm – www.Prop65Warnings.ca.gov

INSTALLATION, OPERATION and MAINTENANCE

6" to 12" Combination Air Valves with Surge Check

INTRODUCTION

This manual provides information to install, operate and maintain GA Industries pilot-operated pressure reducing valves to ensure a long service life. The valve is ruggedly constructed to provide many decades of dependable service with minimal maintenance.

CAUTION

The valve is NOT recommended for use with toxic, corrosive, or flammable fluids.

The Shop Order (SO) Number, Figure Number, size, and pressure rating are stamped on a nameplate attached to the valve. Please refer to the SO number when ordering parts.

The Figure 983-D is suitable for use with finished water, raw water and treated effluent that is free of debris.

DESCRIPTION OF OPERATION

The Figure 983-D consists of a Figure 930-D flanged air & vacuum valve, a Figure 920 air release valve and a Figure F284-D surge check, factory assembled and tested as a unit.

Refer to Page 2 for identification and location of the individual valves that comprise the assembly.

The valve is open when void of water. Air is discharged through the air vacuum valve's large orifice as the system is filled with water. An excessive air discharge rate closes the surge check to reduce the discharge area, slowing the air & vacuum valve closure to reduce slam and surge associated with a sudden air valve closure. After the air & vacuum valve is closed and the system is pressurized, any air that collects in the valve is automatically vented through the air release valve's small orifice. The air & vacuum valve re-opens to admit air when the system is drained, or a negative system pressure occurs.

RECEIVING AND STORAGE

Inspect the valve upon receipt for damage during shipment. Carefully unload all valves to the ground without dropping.

Valves should remain in a clean, dry, and weather protected area until installed. After completion of shop testing the valve is drained of the test water but

a small residual amount could remain so the valve should be protected from freezing during storage.

INSTALLATION

Figure Number 983-D has an ANSI Class 125 flanged pipeline connection. The air & vacuum valve outlet is supplied with a protective cowl or an optional Class 125 flanged outlet that can be piped to a drain

The valve must be installed in a vertical orientation for it to properly function.

Prior to installation ensure all debris, packing material or other foreign material has been removed from both ports.

If installed outdoors, below ground in a vault or in an unheated area, adequate freeze protection must be provided.

Adequate isolating valves should be installed between the valve and the pipeline or system to facilitate maintenance. If a butterfly valve is used, be aware of the required disc clearance shown in the O & M for the Figure 284-D.

The valve should be installed with sufficient clearance to permit maintenance and removal of internal components.

The valve is not designed to support adjacent equipment; piping loads should not be imposed on the valve and large valves should be properly supported.

Flat-faced flanged valves should be mated with flat-faced flanges and full-face gaskets. If ring gaskets are used the bolt material shall be ASTM A307 Grade B (or equivalent). Higher strength bolting should only be used with full-face gaskets.

Lower heavy valves using slings or chains around the valve body and/or the lifting eyes. DO NOT LIFT BY THE EXTERNAL PIPING. Lubricate the bolts or studs and insert around flange. Lightly tighten bolts until gaps are eliminated. Torque bolts in an alternating pattern in graduated steps. If leakage occurs wait 24 hours and re-torque the bolts but do not compress the gasket more than 50% or exceed bolt maximum torque rating.

START-UP

The valve does not require any calibration or adjustment prior to putting it into service.

In rare situations, it may be necessary to “adjust” the surge check’s reduced area. If noted that the air & vacuum valve “slams” shut and/or there is a significant pressure surge when the valve closes, install a pipe plug in one of the tapped holes in the surge check disc. If this does not mitigate the slam/surge install another pipe plug. **DO NOT PLUG ALL THE HOLES.**

PREVENTATIVE MAINTENANCE

No routine lubrication or adjustments are needed. The valve should be visually to check for leaks. If leakage is detected, see **TROUBLESHOOTING** to resolve.

WARNING

Personal injury may occur if the valve is disassembled while pressurized. Before attempting disassembly, follow appropriate lockout/tag out procedures to prevent accidental pressurization.

TESTING

The valve can be tested to ensure it is in good working order.

1. Isolate the valve from the pipeline
2. Slowly loosen/remove the pipe plug at the top of the Figure 920 to de-pressurize the assembly
3. Remove the pipe plug in the side of the Figure 930 just above the pipe flange
4. The float in the Figure 930 should fall as water leaves the valve
5. Replace the pipe plugs and slowly open the isolating valve
6. The Figure 930 float should rise and seal tightly while the Figure 920 may continue to release air for a while then close tightly.

TROUBLESHOOTING

SYMPTOM or PROBLEM	SOLUTION
Leakage from outlet of Air & Vacuum valve when closed	
• Debris lodged between float and seat	Remove debris, inspect for damage
• Worn or damaged seat ring	Inspect, replace (See Figure 930 Repair Instructions)
• Deformed or damaged float	Inspect, replace (See Figure 930 Repair Instructions)
Leakage from outlet of Air Release valve when closed	
• Debris lodged between orifice and orifice button	Remove debris, inspect for damage
• Worn or damaged orifice or orifice button	Inspect, replace (See Figure 905 Repair Instructions)
• Deformed or damaged float	Inspect, replace (See Figure 905 Repair Instructions)

REPAIR INSTRUCTIONS

Refer to the instructions for the inspection, troubleshooting and repair of each of the valves used in the Figure 983-D assembly.

REPLACEMENT PARTS

Genuine replacement parts are available from your local GA Industries representative or from the factory:

VAG USA, LLC
 234 Clay Avenue
 Mars, PA 16046 USA
 Telephone: 724-776-1020
 Fax: 724-776-1254
 E-mail: quotes-ga@vag-group.com

Please have the nameplate data available when ordering parts.

WARRANTY:

The Warranty for GA Industries valves is included in our Terms and Conditions which can be found here: <https://gaindustries.com/terms>

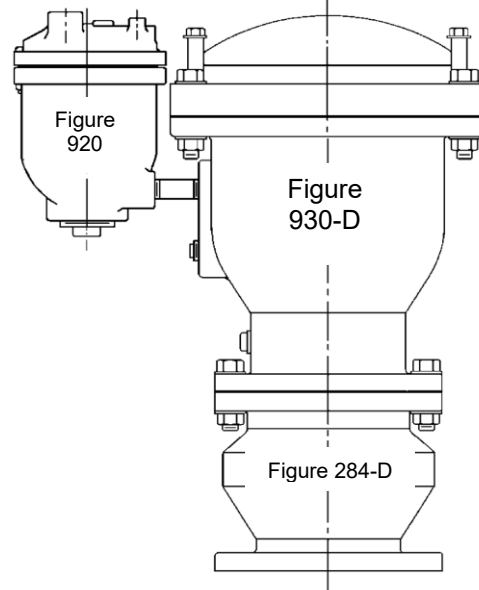

Figure Number	Air Release Valve	Air Vacuum Valve	Surge Check Valve	Max. Working Pressure
983-D	920	930-D	284-D	150 PSI
983H-D	920H	930-D	284-D	200 PSI

This page intentionally left blank

Section 2

INSTALLATION, OPERATION AND MAINTENANCE MANUAL

Figures 930-D, 930-U

**6" & 8" Air & Vacuum Valves
for Clean Water**

Drawing EAV-7049



234 Clay Avenue • Mars, PA 16046 USA
Telephone (724) 776-1020 • Fax (724) 776-1254
E-mail: info-ga@vag-group.com

Manual Number 930.2-IOM 120220 Rev A



WARNING: Cancer and Reproductive Harm – www.Prop65Warnings.ca.gov

INSTALLATION, OPERATION and MAINTENANCE

Figures 930-D, 930-U Air & Vacuum Valves

INTRODUCTION

This manual will provide the information to properly install, operate and maintain the valve to ensure a long service life. The Figure 930 Air & Vacuum Valve is ruggedly constructed to provide years of trouble-free operation with minimal maintenance.

These Air & Vacuum Valves are not intended for use with fluids containing suspended solids such as wastewater and sewage. The GA Industries Figure 935 Sewage Service Air & Vacuum Valves are recommended for such applications.

CAUTION

The valve is NOT recommended for use with toxic fluids, fuels or fluids containing hazardous gases

The Shop Order (SO) Number, Figure Number, size and pressure rating are stamped on a nameplate attached to the valve. Please refer to the SO number when ordering parts.

DESCRIPTION OF OPERATION

The Figure 930 Air & Vacuum Valve allows air that is being pushed ahead of the incoming fluid to escape and ensure a complete filling of the pipeline or vessel. Once the air has been exhausted and the system is pressurized the valve closes tight. It does not re-open unless and until the system is drained and/or a negative pressure condition occurs within the pipe or vessel to admit air to minimize the vacuum condition.

The Figure 930 employs the Kinetic aerodynamic operating principle to ensure the valve is not prematurely blown shut by the high velocity exiting air.

RECEIVING AND STORAGE

Inspect the valve upon receipt for damage during shipment. Carefully unload all valves to the ground without dropping. Do not pick up the

valve by the "cowl." The valves should remain in a clean, dry and weather protected area until installed. For long term storage (greater than 6 months) the rubber surfaces of the seat should be coated with a non-toxic lubricant such as "SuperLube" made by Synco Chemical. Do not expose the rubber parts to sunlight or ozone.

INSTALLATION

Figure Numbers suffixed with "D" (e.g., 930-D) indicate the valve has ANSI Class 125 flanged pipeline connection. Figure Numbers suffixed with "U" (e.g., 930-U) indicate the valve has ANSI Class 250 flanged pipeline connection.

Sizes 6" & 8" Figure Numbers 930-D and 930-U are standard with an outlet cowl, indicated by a "C" (e.g., 930-DC). In lieu of a cowl, the valve can be supplied with an ANSI Class 125 flanged outlet connection, indicated by a "J" (e.g., 930-UJ).

Consult the drawings of record to verify the configuration supplied and installed.

The valve must be installed in an upright vertical orientation, normally at a high point in the system.

If installed outdoors, below ground in a vault or in an unheated area, adequate freeze protection must be provided. Some discharge of water may occur just prior to valve closure. If installed indoors or in a vault, the valve outlet should be directed to an adequate drain.

An isolating valve should be installed between the valve and the pipeline or system to facilitate maintenance.

Carefully screw threaded end valves onto pipe nipple using compatible thread sealant. Tighten valve using wrench flats. DO NOT OVERTIGHTEN.

Flat-faced flanged valves should be mated with flat-faced flanges and full-face gaskets. If ring

gaskets are used the bolt material shall be ASTM A307 Grade B (or equivalent). Higher strength bolting should only be used with full-face gaskets.

Lower heavy valves using slings or chains around the valve body and/or the lifting eye. Lubricate the bolts or studs and insert around flange. Lightly tighten bolts until gaps are eliminated. Torque bolts in an alternating pattern in graduated steps. If leakage occurs wait 24 hours and re-torque the bolts but do not compress the gasket more than 50% or exceed bolt maximum torque rating.

VALVE CONSTRUCTION

The standard Figure 930 Air & Vacuum Valve has a cast iron body and cover, a 316 stainless steel float ball, Buna-N rubber seat and an outlet cowl. Refer to the List of Materials submitted for the order if non-standard materials were provided.

Refer to Page 4 for details of construction and parts location.

The body (1) has an inlet connection at the bottom where the valve attaches to the system and an outlet connection at the top through which air leaves the valve (during filling) and enters the valve (during draining). The outlet may be fitted with a "cowl" to deflect air during venting and minimize entry of foreign matter during air admission or a flanged connection to permit the outlet to be piped to a drain.

WARNING

Removing the valve from the line or disassembling the valve while there is pressure in the valve body may result in injury or damage to the valve

PREVENTIVE MAINTENANCE

Figure 930 Air & Vacuum Valves require no scheduled lubrication, adjustment or preventive maintenance.

The float ball with attached float guide are the only moving parts and require no lubrication.

A periodic visual inspection should be performed to ensure the outlet piping is not obstructed and to verify there is no fluid leakage.

TESTING

Valve operation can be easily tested. Close the inlet isolation valve and remove or loosen the pipe plug nearest the inlet to drain the water from the valve. The float should drop as vacuum forms inside the valve as the water leaves. NOTE: A ball or gate valve can be installed in place of the pipe plug to facilitate testing.

Replace or tighten the pipe plug and slowly open the inlet isolating valve. The valve should float closed and seat tightly when pressurized.

TROUBLESHOOTING

- Valve Does Not Close / Fluid Leakage
Verify debris has not collected on the seat preventing tight closure

Verify the pressure at the valve inlet is at least 10 PSI

Verify rubber seat and/or float ball seating surfaces are not deformed or damaged

Verify float guide is undamaged and attached to float

Verify float has buoyancy

Verify float ball rises freely without binding or sticking

- Valve Does Not Open
Verify there is no pressure inside the valve.

Verify there is no debris in the valve that is preventing the float from freely falling when fluid is drained from valve

DISASSEMBLY

Although small a size Figure 930 Air & Vacuum Valve may be more easily serviced by removing it from the line, all valves can be serviced while the body remains connected to the pipeline. A skilled technician with proper tools should perform all work. No special tools are required.

First ensure there is no pressure within the valve. Remove the cover bolts and nuts (4 and 8) and lift off cover (2), it may be necessary to pry the cover off.

Remove the rubber seat (3) and lift out the float ball (5) with float guide (12) attached. Remove the rubber cushion (7) and flange bearing (12).

Inspect all parts for wear and damage. Minor scratches in the float are normal. Some floats may contain sand for added weight but if water is detected replace the float. Clean any scale build up from the float ball. Replace damaged parts.

REASSEMBLY

Reassembly is performed in reverse order from disassembly. Clean all parts especially the threaded, seating and sealing surfaces before reassembling valve. Worn or damaged parts should be replaced.

Carefully introduce pressure and check for leaks.

REPLACEMENT PARTS

Genuine replacement parts are available from your local VAG/GA Industries representative or from the factory:

VAG USA, LLC
 234 Clay Avenue
 Mars, PA 16046 USA
 Telephone: 724-776-1020
 Fax: 724-776-1254
 E-mail: quotes-ga@vag-group.com

Please have the nameplate data available when ordering parts.

REPAIR KITS

Soft Goods Repair Kits
 6" Kit A930-6 Part Number 2-80-11000-017
 8" Kit A930-8 Part Number 2-80-11000-018

Soft goods kit contains items 3 and 7

All other parts ordered individually

WARRANTY

The Warranty for GA Industries valves is included in our Terms and Conditions which can be found here: <https://gaindustries.com/terms>

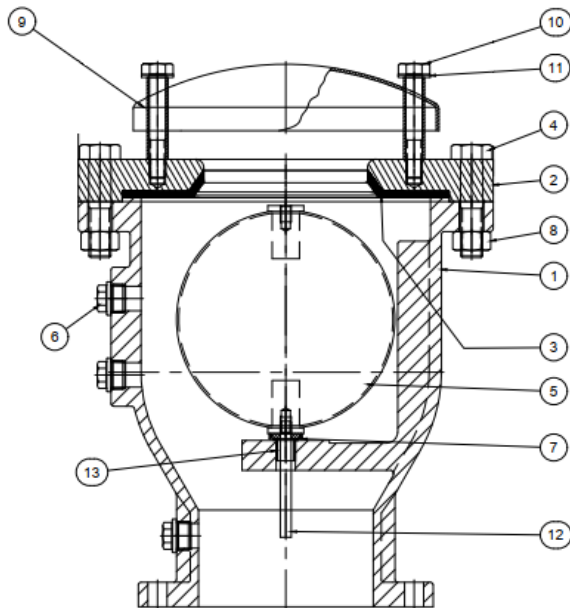

PARTS LIST
 6" and 8" Figures 930-D, 930-U

Item	Name	Standard Material
1.	Body	Cast Iron
2.	Cover	Cast Iron
3.	Seat	Buna-N Rubber
4.	Cover Bolts	Zinc Plated Steel or 316SS
5.	Float Ball	316 Stainless Steel
6.	Pipe Plug	Malleable Iron
7.	Cushion	EPDM Rubber
8.	Cover Nut	Zinc Plated Steel or 316 SS
9.	Cowl	Steel
10.	Cowl Bolt	Zinc Plated Steel or 316 SS
11.	Cowl Washer	Zinc Plated Steel or 316 SS
12.	Float Guide	303 Stainless Steel
13.	Bearing	Acetal Copolymer

Note: Parts 9, 10 & 11 not supplied on Figure 930-DJ or 930-UJ Air & Vacuum Valves with flanged outlet.

Section 3

INSTALLATION, OPERATION AND MAINTENANCE MANUAL

Figures 930-D, 930-U

10" & 12" Air & Vacuum Valves for Clean Water



234 Clay Avenue • Mars, PA 16046 USA
Telephone (724) 776-1020 • Fax (724) 776-1254
E-mail: info-ga@vag-group.com

Manual Number 930.3-IOM 120320 Rev A



WARNING: Cancer and Reproductive Harm – www.Prop65Warnings.ca.gov

INSTALLATION, OPERATION and MAINTENANCE

10" & 12" Figures 930-D, 930-U Air & Vacuum Valves

INTRODUCTION

This manual will provide the information to properly install, operate and maintain the valve to ensure a long service life. The Figure 930 Air & Vacuum Valve is ruggedly constructed to provide years of trouble-free operation with minimal maintenance.

These Air & Vacuum Valves are not intended for use with fluids containing suspended solids such as wastewater and sewage. The GA Industries Figure 935 Sewage Service Air & Vacuum Valves are recommended for such applications.

CAUTION

The valve is NOT recommended for use with toxic fluids, fuels or fluids containing hazardous gases

The Shop Order (SO) Number, Figure Number, size and pressure rating are stamped on a nameplate attached to the valve. Please refer to the SO number when ordering parts.

DESCRIPTION OF OPERATION

The Figure 930 Air & Vacuum Valve allows air that is being pushed ahead of the incoming fluid to escape and ensure a complete filling of the pipeline or vessel. Once the air has been exhausted and the system is pressurized the valve closes tight. It does not re-open unless and until the system is drained and/or a negative pressure condition occurs within the pipe or vessel to admit air to minimize the vacuum condition.

The Figure 930 employs the Kinetic aerodynamic operating principle to ensure the valve is not prematurely blown shut by the high velocity exiting air.

RECEIVING AND STORAGE

Inspect the valve upon receipt for damage during shipment. Carefully unload all valves to the ground without dropping. Do not pick up the valve by the "cowl." The valves should remain in a clean, dry and weather protected area until installed.

For long term storage (greater than 6 months) the rubber surfaces of the seat should be coated with a non-toxic lubricant such as "SuperLube" made by Synco Chemical. Do not expose the rubber parts to sunlight or ozone.

INSTALLATION

Figure Numbers suffixed with "D" (e.g., 930-D) indicate the valve has ANSI Class 125 flanged pipeline connection. Figure Numbers suffixed with "U" (e.g., 930-U) indicate the valve has ANSI Class 250 flanged pipeline connection.

Sizes 10" & 12" Figure Numbers 930-D and 930-U are standard with an outlet cowl, indicated by a "C" (e.g., 930-DC). In lieu of a cowl, the valve can be supplied with an ANSI Class 125 flanged outlet connection, indicated by a "J" (e.g., 930-UJ).

Consult the drawings of record to verify the configuration supplied and installed.

The valve must be installed in an upright vertical orientation, normally at a high point in the system.

If installed outdoors, below ground in a vault or in an unheated area, adequate freeze protection must be provided. Some discharge of water may occur just prior to valve closure. If installed indoors or in a vault, the valve outlet should be directed to an adequate drain.

An isolating valve should be installed between the valve and the pipeline or system to facilitate maintenance.

Carefully screw threaded end valves onto pipe nipple using compatible thread sealant. Tighten valve using wrench flats. DO NOT OVER-TIGHTEN.

Flat-faced flanged valves should be mated with flat-faced flanges and full-face gaskets. If ring

gaskets are used the bolt material shall be ASTM A307 Grade B (or equivalent). Higher strength bolting should only be used with full-face gaskets.

Lower heavy valves using slings or chains around the valve body and/or the lifting eye. Lubricate the bolts or studs and insert around flange. Lightly tighten bolts until gaps are eliminated. Torque bolts in an alternating pattern in graduated steps. If leakage occurs wait 24 hours and re-torque the bolts but do not compress the gasket more than 50% or exceed bolt maximum torque rating.

VALVE CONSTRUCTION

The standard Figure 930 Air & Vacuum Valve has a cast iron body and cover, a 316 stainless steel float ball, Buna-N rubber seat and an outlet cowl. Refer to the List of Materials submitted for the order if non-standard materials were provided.

Refer to Page 4 for details of construction and parts location.

The body (1) has an inlet connection at the bottom where the valve attaches to the system and an outlet connection at the top through which air leaves the valve (during filling) and enters the valve (during draining). The outlet may be fitted with a "cowl" to deflect air during venting and minimize entry of foreign matter during air admission or a flanged connection to permit the outlet to be piped to a drain.

WARNING

Removing the valve from the line or disassembling the valve while there is pressure in the valve body may result in injury or damage to the valve

PREVENTIVE MAINTENANCE

Figure 930 Air & Vacuum Valves require no scheduled lubrication, adjustment or preventive maintenance.

The float ball with attached float guide are the only moving parts and require no lubrication.

A periodic visual inspection should be performed to ensure the outlet piping is not obstructed and to verify there is no fluid leakage.

TESTING

Valve operation can be easily tested. Close the inlet isolation valve and remove or loosen the pipe plug nearest the inlet to drain the water from the valve. The float should drop as vacuum forms inside the valve as the water leaves. NOTE: A ball or gate valve can be installed in place of the pipe plug to facilitate testing.

Replace or tighten the pipe plug and slowly open the inlet isolating valve. The valve should float closed and seat tightly when pressurized.

TROUBLESHOOTING

- Valve Does Not Close / Fluid Leakage
Verify debris has not collected on the seat preventing tight closure

Verify the pressure at the valve inlet is at least 10 PSI

Verify rubber seat and/or float ball seating surfaces are not deformed or damaged

Verify float guide is undamaged and attached to float

Verify float has buoyancy

Verify float ball rises freely without binding or sticking

- Valve Does Not Open
Verify there is no pressure inside the valve.

Verify there is no debris in the valve that is preventing the float from freely falling when fluid is drained from valve

DISASSEMBLY

Although small size Figure 930 Air & Vacuum Valves may be more easily serviced by removing it from the line, all valves can be serviced while the body remains connected to the pipeline. A skilled technician with proper tools should perform all work. No special tools are required.

First ensure there is no pressure within the valve. Remove the cover bolts and nuts (4 and 8) and lift off cover (2), it may be necessary to pry the cover off.

Lift out the float ball (10) with float guide (9) attached. Remove the rubber cushion (8) and flange bearing (13).

Invert cover and remove O-ring (6), seat screws (5), follower ring (4) and seat (3).

Inspect all parts for wear and damage. Minor scratches in the float are normal. Some floats may contain sand for added weight but if water is detected replace the float. Clean any scale build up from the float ball. The float ball (10) can be inverted to obtain a fresh sealing surface. Replace damaged parts.

REASSEMBLY

Reassembly is performed in reverse order from disassembly. Clean all parts especially the threaded, seating and sealing surfaces before reassembling valve. Worn or damaged parts should be replaced.

Carefully introduce pressure and check for leaks.

REPLACEMENT PARTS

Genuine replacement parts are available from your local VAG/GA Industries representative or from the factory:

VAG USA, LLC
 234 Clay Avenue
 Mars, PA 16046 USA
 Telephone: 724-776-1020
 Fax: 724-776-1254
 E-mail: quotes-ga@vag-group.com

Please have the nameplate data available when ordering parts.

REPAIR KITS

Soft Goods Repair Kits
 10" Kit A930-10 Part Number 2-80-11000-012
 12" Kit A930-12 Part Number 2-80-11000-013

Soft goods kit contains items 3, 6 and 8

All other parts ordered individually

WARRANTY

The Warranty for GA Industries valves is included in our Terms and Conditions which can be found here: <https://gaindustries.com/terms>

PARTS LIST
 10" and 12" Figures 930-D, 930-U

Item	Name	Standard Material
1.	Body	Cast Iron
2.	Cover	Cast Iron
3.	Seat	Buna-N Rubber
4.	Follower Ring	316 Stainless Steel
5.	Seat Screws	304 Stainless Steel
6.	Cover O-ring	Buna-N Rubber
7.	Cover Bolt	Zinc Plated Steel or 316 SS
8.	Cushion	EPDM Rubber
9.	Float Guide	303 Stainless Steel
10.	Float Ball	316 Stainless Steel
11.	Pipe Plug	Steel
12.	Cover Nut	Zinc Plated Steel or 316 SS
13.	Guide Bearing	Acetal Copolymer
14.	Cowl	Steel
15.	Cowl Bolt	Zinc Plated Steel or 316 SS
16.	Cowl Washer	Zinc Plated Steel or 316 SS

Note: Parts 14, 15 & 16 not supplied on Figure 930-DJ or 930-UJ Air & Vacuum Valves with flanged outlet.

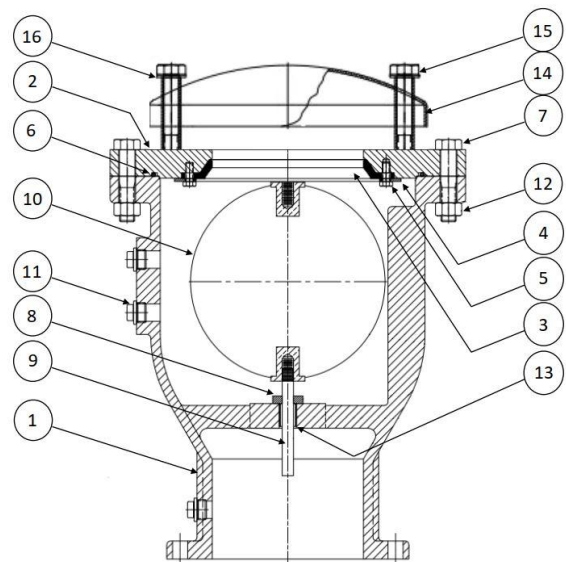

Section 4

INSTALLATION, OPERATION AND MAINTENANCE MANUAL

Figure 920

1" & 2" Compound Lever Air Release Valves

Drawing EAR-7003



234 Clay Avenue • Mars, PA 16046 USA
Telephone (724) 776-1020 • Fax (724) 776-1254
E-mail: info-ga@vag-group.com

Manual Number 920-IOM 022420 Rev E



WARNING: Cancer and Reproductive Harm – www.Prop65Warnings.ca.gov

INSTALLATION, OPERATION INSTALLATION, OPERATION and MAINTENANCE

Figure 920 Air Release Valves

INTRODUCTION

This manual will provide the information to properly install, operate and maintain the valve to ensure a long service life. The Air Release Valve is ruggedly constructed to provide years of trouble-free operation with minimal maintenance.

These Air Release Valves are not intended for use with fluids containing suspended solids such as wastewater and sewage. The GA Industries Figure 925, 927 or 929 Air Release Valves are recommended for such applications.

CAUTION

The valve is NOT recommended for use with toxic fluids, fuels or fluids containing hazardous gases

CAUTION

The valve will not function if used at a pressure higher than the maximum working pressure indicated on the nameplate.

The Shop Order (SO) Number, Figure Number, size and pressure rating are stamped on a nameplate attached to the valve. Please refer to the SO number when ordering parts.

DESCRIPTION OF OPERATION

The Air Release Valve is designed to automatically vent air that has accumulated within the valve. These valves are usually installed at high points in the system where air tends to collect. The valve is "normally open" and will vent air through its orifice at the top of the valve. The float rises when water enters the valve and closes the orifice. Air from the system accumulates in the valve forcing the water level down until the float drops and opens the venting orifice. As air is released the water level rises lifting the float and re-closing the valve.

This sequence occurs as often as necessary to release air that has collected in the valve.

RECEIVING AND STORAGE

Inspect the valve upon receipt for damage during shipment. Carefully unload all valves to the ground without dropping.

The valves should remain in a clean, dry and weather protected area until installed. For long term storage (greater than 6 months) the rubber surfaces of the seat should be coated with a non-toxic lubricant such as "SuperLube" made by Synco Chemical. Do not expose the rubber parts to sunlight or ozone.

INSTALLATION

The Figure 920 is standard with NPT screwed connections. An optional flange pipeline connection is available on special order.

Consult the drawings of record to verify the configuration supplied and installed.

The valve must be installed in an upright vertical orientation, normally at a high point in the system.

If installed outdoors, below ground in a vault or in an unheated area, adequate freeze protection must be provided. Some discharge of water may occur during operation so the valve outlet should be piped to an adequate drain.

An isolating valve should be installed between the valve and the pipeline or system to facilitate maintenance.

Carefully screw threaded end valves onto pipe nipple using compatible thread sealant. Tighten valve using wrench flats. DO NOT OVERTIGHTEN.

Flat-faced flanged valves should be mated with flat-faced flanges and full-face gaskets. If ring gaskets are used the bolt material shall be ASTM A307 Grade B (or equivalent). Higher strength bolting should only be used with full-face gaskets.

Lower heavy valves over the mating flange using slings or chains around the valve body. Lubricate the bolts or studs and insert around flange. Lightly tighten bolts until gaps are eliminated. Torque bolts in an alternating pattern in graduated steps. If leakage occurs wait 24 hours and re-torque the bolts but do not compress the gasket more than 50% or exceed bolt maximum torque rating.

VALVE CONSTRUCTION

The standard Figure 920 Air Release Valve has a cast iron body and cover, 316 stainless steel float and linkage mechanism and a rubber seat. Optional materials such as 316 stainless steel or ductile iron body and cover can be provided. Refer to the List of Materials submitted for the order if non-standard materials were provided.

Refer to Page 4 for details of construction and parts location.

The body (1) has an inlet connection at the bottom where the valve attaches to the system and a smaller outlet connection at the top through which air leaves the valve.

WARNING

Removing the valve from the line or disassembling the valve while there is pressure in the valve body may result in injury or damage to the valve

PREVENTIVE MAINTENANCE

Figure 920 Air Release Valves require no scheduled lubrication, adjustment or preventive maintenance.

A periodic visual inspection should be performed to ensure the outlet piping is not obstructed and to verify there is no fluid leakage.

TESTING

Valve operation can be easily tested. Close the inlet isolation valve and remove or loosen the pipe plug nearest the inlet to drain the water from the valve. The float should drop as the water leaves the valve. NOTE: A ball or gate valve can be installed in place of the pipe plug to facilitate testing.

Replace or tighten the pipe plug and slowly open the inlet isolating valve. The valve should float closed and seat tightly.

TROUBLESHOOTING

- Valve Does Not Close / Fluid Leakage

Verify debris has not collected on the seat preventing tight closure

Verify rubber orifice button and/or orifice seating surfaces are not damaged

Verify float has buoyancy

Verify linkage mechanism operates freely without binding or sticking

Verify the pressure at the valve inlet is at least 10 PSI

- Valve Does Not Open

Verify debris in the valve is not preventing the float from freely falling when fluid is drained from valve

Verify linkage mechanism operates freely without binding or sticking

Verify the pressure at the valve inlet does not exceed the maximum working pressure

DISASSEMBLY

While small valves may be more easily serviced by removing it from the line, all valves can be serviced while the body remains connected to the pipeline. A skilled technician with proper tools should perform all work. No special tools are required.

First ensure there is no pressure within the valve. Remove the cover bolts and nuts (16 & 17) and lift off cover (2) with float and linkage attached. It may be necessary to pry the cover off. Be careful no to damage or lose O-ring (21).

Remove the two spring pins connecting the lever arm (5) and float arm (6) to the bracket (3). The float and linkage will be free from the cover.

Remove the spring pin connecting the pivot link (12) to the float arm (6) and remove the float screw (13) and lockwasher (9). Remove the hex nut (8) and lockwasher (9) and unscrew the orifice button (7) from the lever arm (5).

Remove the bracket screw (4) to remove the leverage bracket (3). Using a hex socket remove the orifice (20) from the cover.

Inspect all parts for wear and damage. Minor scratches and dents in the float are normal. Some floats may contain sand for added weight but if water is detected replace the float. Carefully clean the orifice of scale. Replace damaged parts.

REASSEMBLY

Clean all parts especially seating and sealing surfaces before reassembling valve. Worn parts should be replaced during re-assembly.

Apply Loctite® PST thread sealant to orifice (20) and thread into cover. Torque to maximum 22 ft-lbs.

Thread orifice button (7) all the way into lever arm (5) and install hex nut (8) and lockwasher (9) but do not tighten. Connect the lever arm (5) and float arm (6) to the bracket (3) using two spring pins.

Adjust the orifice button (7) so that the end of the lever arm (5) nearest the orifice button is about 1/16" (1.6mm) farther from the cover than the opposite end when the orifice button (7) is gently resting on the orifice (20). Secure by tightening hex nut (8)

Secure float (15) to pivot link (12) using screw (13) and lockwasher (9). Attach pivot link (12) to float arm (6) using spring pin. Verify free movement of linkage mechanism and that the orifice button (7) presses against the orifice (3) when the float is lifted and pulls away when falls.

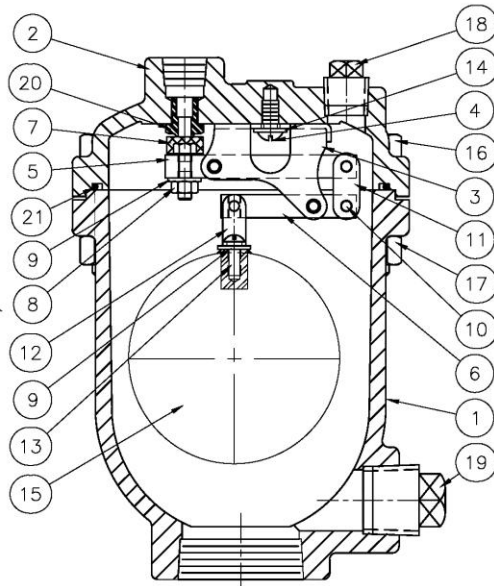

Lubricate and place O-ring (21) in cover (2) and carefully place cover (2) on body (1) ensuring o-ring is retained. Install the cover bolts (16) and nuts (17) and tighten in an alternating pattern.

Carefully introduce pressure and check for leaks

REPLACEMENT PARTS

Genuine replacement parts are available from your local VAG/GA Industries representative or from the factory:

VAG USA, LLC
 234 Clay Avenue
 Mars, PA 16046 USA
 Telephone: 724-776-1020
 Fax: 724-776-1254
 E-mail: quotes-ga@vag-group.co

Please have the nameplate data available when ordering parts.

REPAIR KITS

Soft Goods Kit A920 (Part Number 2-80-11000-005) includes Items 7, 8, 9 and 21.

Linkage Kit AL920 (Part Number 2-80-11000-081) includes Items 3, 4, 5, 6, 10, 11, 12 and 14

WARRANTY:

The Warranty for GA Industries valves is included in our Terms and Conditions which can be found here: <https://gaindustries.com/terms>

PARTS LIST

Item	Name	Material
1.	Body	Cast Iron
2.	Cover	Cast Iron
3.	Bracket	316 Stainless Steel
4.	Bracket Screw	304 Stainless Steel
5.	Lever Arm	316 Stainless Steel
6.	Float Arm	316 Stainless Steel
7.	Orifice Button	Buna-N/Stainless Steel
8.	Hex Nut	304 Stainless Steel
9.	Lock Washer	302 Stainless Steel
10.	Spring Pin	316 Stainless Steel
11.	Valve Link	316 Stainless Steel
12.	Pivot Link	316 Stainless Steel
13.	Float Screw	304 Stainless Steel
14.	Lock Washer	410 Stainless Steel
15.	Float Ball	316 Stainless Steel
16.	Cover Bolts	Zinc Plated Steel or 316SS
17.	Cover Nuts	Zinc Plated Steel or 316SS
18.	Pipe Plug	Steel or 316SS
19.	Pipe Plug	Malleable Iron or 316SS
20.	Orifice	316 Stainless Steel
21.	O-Ring	Buna-N Rubber

This page intentionally left blank.

Section 5

INSTALLATION, OPERATION AND MAINTENANCE MANUAL

Figure F284-D Anti-Slam Surge Check Valves



234 Clay Avenue
Mars, PA 16046 USA
Telephone (724) 776-1020
Fax (724) 776-1254
E-mail: info-ga@vag-group.com

IOM F284D 070822



WARNING: Cancer and Reproductive Harm – www.Prop65Warnings.ca.gov

INSTALLATION, OPERATION and MAINTENANCE

Anti-Slam Surge Check Valves

INTRODUCTION

This manual will provide the information to properly install, operate and maintain the valve to ensure a long service life. GA Industries Surge Check Valves are ruggedly constructed to provide years of trouble-free operation with minimal maintenance.

CAUTION

The valve is NOT recommended for use with compressed air or other gases.

CAUTION

Surge Check Valves are not intended for used with hazardous, flammable, or toxic fluids.

The Shop Order (SO) Number, Figure Number, size and pressure rating are stamped on a nameplate attached to the valve. Please refer to the SO number when ordering parts.

DESCRIPTION OF OPERATION

GA Industries Anti-Slam Surge Check Valves are designed to minimize the surge pressure and valve damage that can result when an air & vacuum valve is suddenly closed by the high velocity incoming water. The surge check valve automatically closes to restrict the discharge area upon excessive air discharge velocity or a sudden transition from air to water. The restricted area slows the incoming water velocity, the air valve is not slammed shut and surges are minimized.

Once the air valve is closed, the surge check reopens to allow unrestricted air inflow.

RECEIVING AND STORAGE

Inspect the valve upon receipt for damage during shipment. Carefully unload all valves to the ground without dropping.

The valves should remain in a clean, dry, and weather protected area until installed. For long term storage (greater than 6 months) the rubber surfaces of the seat should be coated with a non-toxic lubricant such as "SuperLube" made

by Synco Chemical. Do not expose the rubber parts to sunlight or ozone.

VALVE CONSTRUCTION

GA Industries Figure F284-D Anti-slam Surge Check Valves have a globe style valve body with integral flanges that are faced and drilled per ANSI Class 125/150.

The valve has a fusion bond epoxy coated ductile iron body, lead free bronze internal metal components and a rubber seat. Refer to Page 4 for details of construction and parts location.

INSTALLATION

GA Industries Figure 284-D Anti-Slam Surge Check Valves are usually supplied as a component of a factory assembly consisting of an air & vacuum valve or combination air valve and a surge check valve.

The Figure 284-D can also be supplied as a separate valve for field installation between the air & vacuum valve or combination air valve and its inlet isolating valve. In this case ensure the valve is installed so that the end of the valve that has the bronze seat with "spokes" is connected to the air valve.

CAUTION

Do not lift the valve by the bronze seat ring spokes

The valve should be installed between standard ANSI Class 125 or 150 flat faced flanges. Full face flange gaskets are recommended.

Remove all packing materials from the valve, including the tabs that retain the seat during shipping.

If ring gaskets are used the bolt material shall be ASTM A307 Grade B (or equivalent). Higher strength bolting should only be used with full-face gaskets.

Lower heavy valves using slings or chains around the valve body. Lubricate the bolts or studs and insert around flange. Lightly tighten bolts until gaps are eliminated. Torque bolts in an alternating pattern in graduated steps. If leakage occurs wait 24 hours and re-torque the bolts but do not compress the gasket more than 50% or exceed bolt maximum torque rating.

If installed outdoors, below ground in a vault or in an unheated area, adequate freeze protection must be provided.

Sizes 10-inch and smaller Figure F284-D Anti-Slam Surge Check Valves have enough clearance to allow it to be bolted to most butterfly valves. Refer to Table 1 on page 4 for clearance dimensions. However, the plug shaft in 12-inch size valves extends past the outlet flange and will interfere with an adjacent butterfly valve's operation.

PREVENTIVE MAINTENANCE

GA Industries Figure 284-D Anti-Slam Surge Check Valves require no scheduled lubrication, adjustment, or preventive maintenance but a periodic visual inspection should be performed.

TROUBLESHOOTING

If the associated air valve slams shut, close one or more of the restriction ports in the Anti-Slam Surge Check Valve disc by installing pipe plug(s).

<p style="text-align: center;">WARNING</p> <p style="text-align: center;">Removing the valve from the line or disassembling the valve while there is pressure in the valve body may result in injury or damage to the valve</p>
--

DISASSEMBLY

The valve should be removed from the line before disassembly. A skilled technician with proper tools should perform all work. No special tools are required.

Set the valve, with the flow arrow pointing down, on wooden blocks or 2 x 4's under the flange outboard of the bronze seat so that it can drop out of the body. Ensure the surface beneath the valve will not damage the internal components when they drop out of the valve.

Place a metal rod on top of the stem inside the bushing. Hit the top of the rod with a hammer or

mallet and the internal components should drop out of the valve body.

Inspect the seating surfaces. Superficial marks, or discoloration on the mating surface of the poppet are normal. The rubber seat is retained in a "dove-tail" groove in the seat and can be pulled out if damaged

Inspect the plug for damage, especially the guiding surfaces to ensure they have not worn unevenly. If they are not round, it can lead to misalignment and sticking so they should be replaced.

REASSEMBLY

Clean all parts especially the seating and sealing surfaces before reassembling valve. Worn parts should be replaced.

Set valve body on a flat surface with the flow arrow pointing down. Install bushing (2) into body (1). Set spring (3) over bushing (2). Install poppet stem in bushing. Lubricate and install new O-ring in dove-tail groove in seat being careful not to damage or cut the O-ring during installation.

Lubricate the O-Ring (6) and install in the groove on the OD of the seat. It is very important to lubricate this O-ring to prevent damage during installation which will cause a leak and not allow the seat to enter the body.

Place the seat into the valve making sure the seat stem enters the poppet and the poppet enters the bushing.

Using two hands, push down on the seat to pop it into the body. Larger valves may require a 2 x 4 to be placed across the seat and hit with a hammer.

Install valve in line with new gaskets, tighten flange bolts, carefully introduce pressure and check for leaks

REPLACEMENT PARTS

Genuine replacement parts are available from your local VAG/GA Industries representative or from the factory:

VAG USA, LLC
 234 Clay Avenue
 Mars, PA 16046 USA
 Telephone: 724-776-1020
 Fax: 724-776-1254
 E-mail: quotes-ga@vag-group.com

Please have the nameplate data available when ordering parts.

WARRANTY

The Warranty for GA Industries valves is included in our Terms and Conditions which can be found here: <https://gaindustries.com/terms>

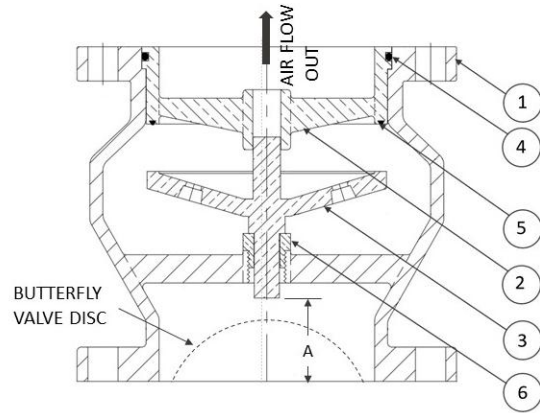

Anti-Slam Surge Check Valve

Item	Description	Standard Material
1	Body	Ductile Iron
2	Seat	Lead Free Bronze
3	Poppet	Lead Free Bronze
4	Seat O-Ring	EPDM Rubber
5	Seal	EPDM Rubber
6	Bushing	Bronze

Table 1 Butterfly Valve Disc Clearance

Size	A
2½"	1¾"
3"	1¾"
4"	1¾"
6"	2½"
8"	3¾"
10"	4¾"
12"	Not applicable

This page intentionally left blank.