

PARTS LIST		
PART	DESCRIPTION	MATERIAL
1	BODY	CAST IRON, ASTM A126 CL B*
2	COVER	CAST IRON, ASTM A126 CL B*
3	LEVERAGE BRACKET	316 STAINLESS STEEL
4	ORIFICE	316 STAINLESS STEEL
5	BRACKET SCREW	304 STAINLESS STEEL
6	LOCKWASHER	410 STAINLESS STEEL
7	ORIFICE BUTTON	BUNA-N / STAINLESS STEEL
8	HEX NUT	304 STAINLESS STEEL
9	LOCK WASHER	410 STAINLESS STEEL
10	COVER SEAL	BUNA-N RUBBER
11	LEVER ARM	316 STAINLESS STEEL
12	FLOAT ARM	316 STAINLESS STEEL
13	SPRING PIN	302 STAINLESS STEEL
14	LINK	316 STAINLESS STEEL
15	UNIVERSAL COUPLING	316 STAINLESS STEEL
16	COVER BOLTS	A307 ZINC PLATED STEEL (OPTIONAL 316 SS)
17	PIPE PLUG 1/2"	STEEL
18	PIPE PLUG 1"	MALLEABLE IRON
19	PIPE PLUG 2"	MALLEABLE IRON
20	FLOAT ROD	316 STAINLESS STEEL
21	FLOAT BALL	316 STAINLESS STEEL
22	FLOAT HOOD	304 STAINLESS STEEL
23	FLOAT HOOD BOLT	304 STAINLESS STEEL
24	CONNECTOR	316 STAINLESS STEEL
25	LOCK WASHER	410 STAINLESS STEEL

* LINED AND COATED WITH NSF-61 CERTIFIED EPOXY

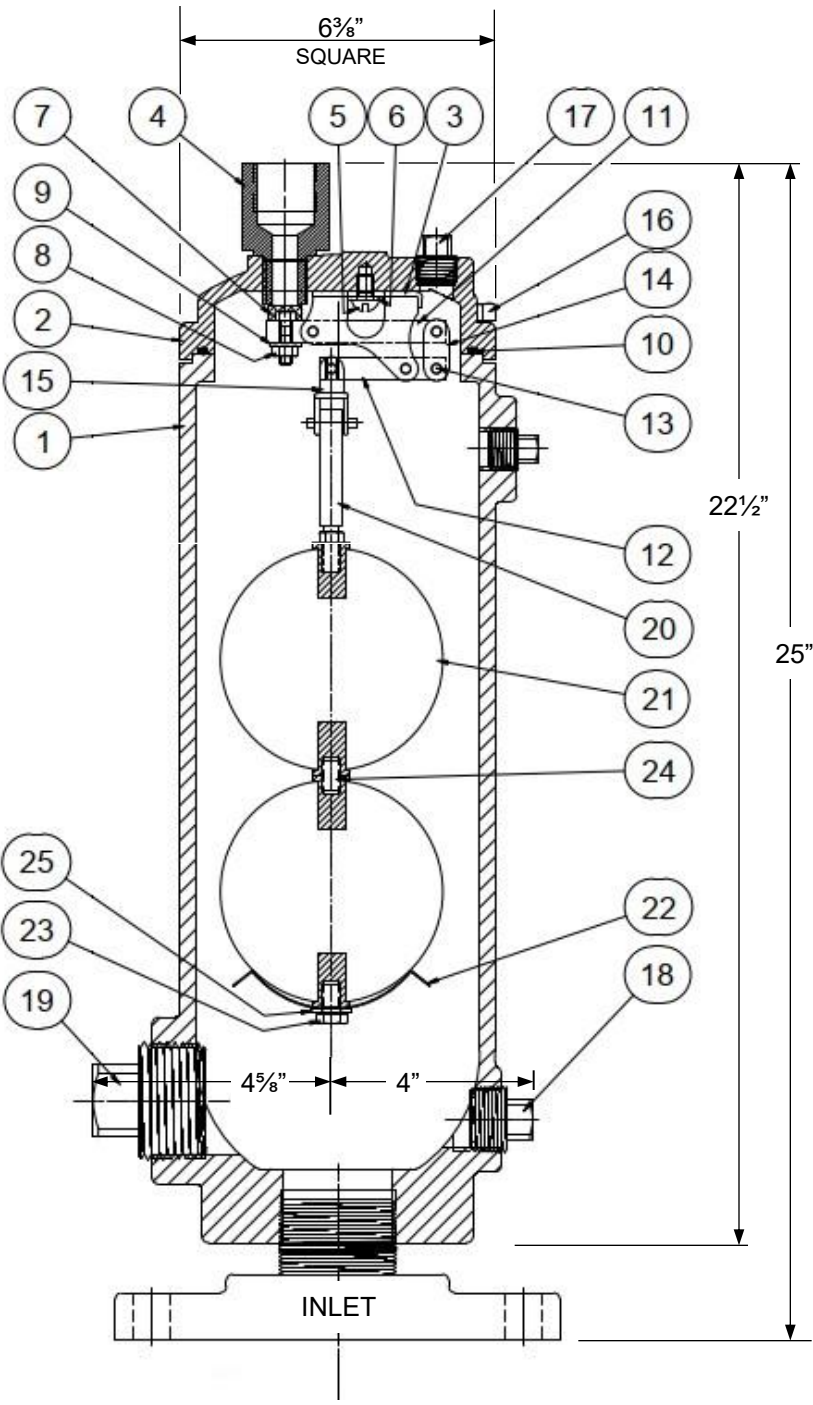

COMPANION FLANGE AND PIPE NIPPLE ONLY USED ON 4" SIZE

FIGURE NUMBER	INLET	OUTLET	ORIFICE DIAMETER	WORKING PRESSURE	PRESSURE RATING	HYDRO TEST PRESSURE
923	2" OR 3" NPT	1" NPT	0.438"	10 - 150 PSI	300 PSI	450 PSI
923H	2" OR 3" NPT	1" NPT	0.375"	10 - 300 PSI		
923H-D	4" ANSI B16.1 CLASS 125	1" NPT	0.375"	10 - 200 PSI		
923H-U	4" ANSI B16.1 CLASS 250	1" NPT	0.375"	10 - 300 PSI		

FIGURE 923 AIR RELEASE VALVES ARE MANUFACTURED AND TESTED IN ACCORDANCE WITH AWWA C512

GA INDUSTRIES a +GF+ Brand

DATE: 6-2-26 DRAWN BY: WJN

2" - 4" SUPER HIGH-CAPACITY AIR RELEASE VALVE

FIGURE 923 DRAWING NO. **EAR-7113W** REV