

NOTES:

1. REFER TO DRAWING EAV-7132.01 FOR LIST OF STANDARD MATERIALS
2. DIMENSIONS AND WEIGHT ARE APPROXIMATE

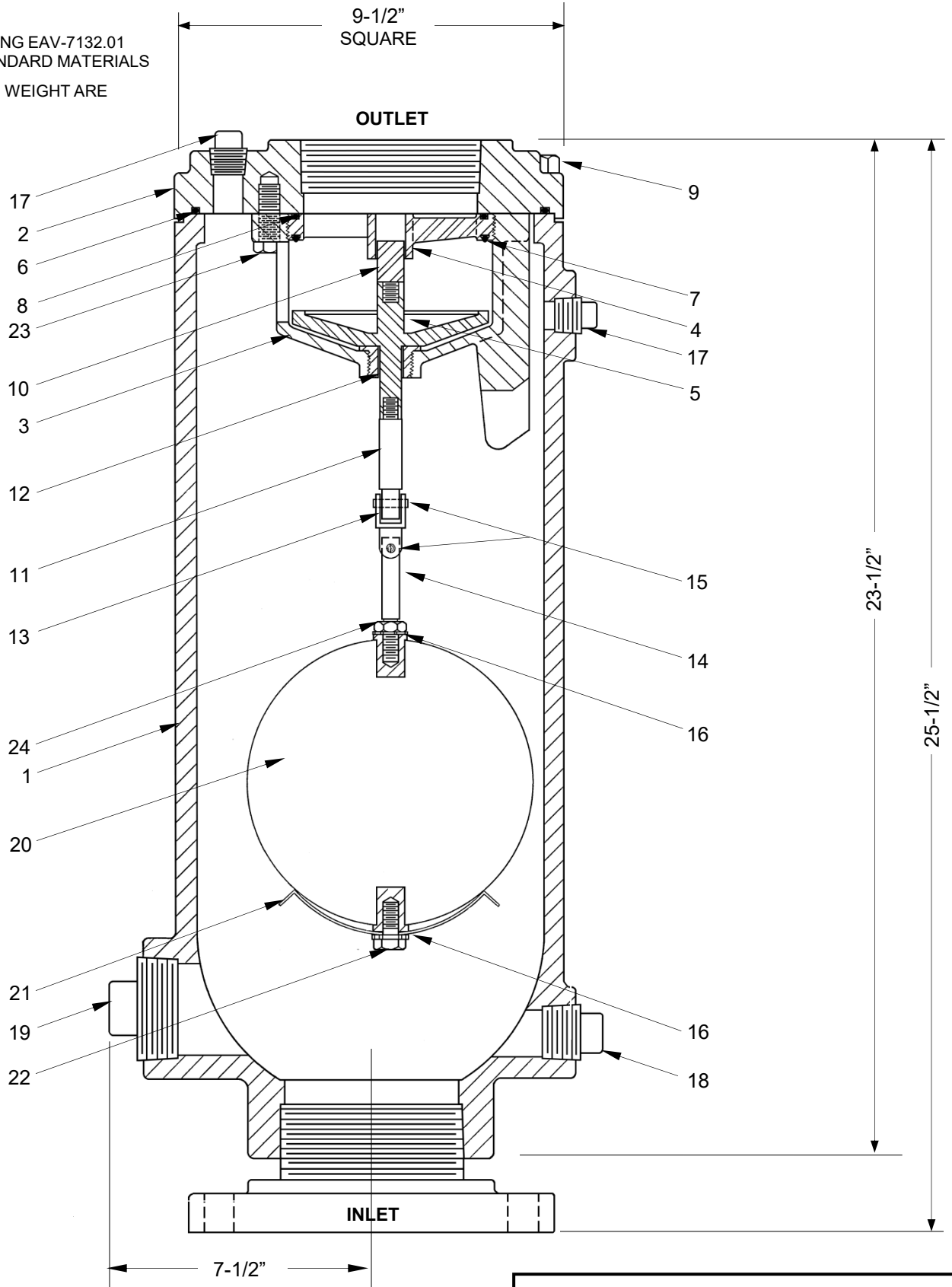

NOTE: VALVE SHOWN IN OPEN POSITION

| | | |
|---|--------|--------------------|
| GA INDUSTRIES a +GF+ Brand | | |
| DATE: | 4/1/09 | DRAWN BY: |
| | | WJN |
| 4" FLANGED SEWAGE AIR & VACUUM VALVE | | |
| FIGURE 935-D | | DRAWING NO. |
| | | EAV-7132A-W |
| | | REV |
| | | A |

| FIGURE NUMBER | INLET | OUTLET | WORKING PRESSURE | PRESSURE RATING | WEIGHT |
|---------------|---------------|--------|------------------|-----------------|----------|
| 935-D | 4" ANSI CL125 | 4" NPT | 10-200 PSI | 200 PSI | 190 lbs. |

LIST of STANDARD MATERIALS
3" & 4" Figure 935
Drawings EAV7132-W, EAV7132.01A-W

| ITEM | NAME | MATERIAL |
|-------------|----------------------|---|
| 1 | Body | Cast Iron, ASTM A126 Class B* |
| 2 | Cover | Cast Iron, ASTM A126 Class B* |
| 3 | Cage | 316 Stainless Steel |
| 4 | Seat | 316 Stainless Steel |
| 5 | Plug | 316 Stainless Steel |
| 6 | Cover O-Ring | Buna-N |
| 7 | Renewable Seat | Buna-N |
| 8 | Cage O-Ring | Buna-N |
| 9 | Cover Bolt | ASTM A307 Zinc Plated Steel (Optional 316SS) |
| 10 | Upper Plug Extension | 316 Stainless Steel |
| 11 | Connector | 316 Stainless Steel |
| 12 | Bushing | 316 Stainless Steel |
| 13 | Universal Coupling | 316 Stainless Steel |
| 14 | Float Rod | 316 Stainless Steel |
| 15 | Spirol Pin | 316 Stainless Steel |
| 16 | Lock Washer | 410 Stainless Steel |
| 17 | ½" Pipe Plug | Steel |
| 18 | 1" Pipe Plug | Malleable Iron |
| 19 | 2" Pipe Plug | Cast Iron |
| 20 | Float Ball | 316 Stainless Steel |
| 21 | Float Hood | 316 Stainless Steel |
| 22 | Float Screw | 18-8 Stainless Steel |
| 23 | Cage Bolt | 18-8 Stainless Steel |
| 24 | Hex Nut | 18-8 Stainless Steel |

* Lined and coated with NSF-61 certified epoxy

| | | |
|---|----------------------------------|-----------------|
| GA INDUSTRIES a +GF+ Brand | | |
| DATE: | 3/17/09 | DRAWN BY: WJN |
| 3" & 4" SEWAGE AIR & VACUUM VALVE LIST OF STANDARD MATERIALS | | |
| FIGURE 935 | DRAWING NO. EAV7132.01 | REV A |