

SIZE	INLET	OUTLET	WORKING PRESSURE
2" X 1"	2" NPT	1" NPT	10-200 PSI
2" X 2"	2" NPT	2" NPT	
3" X 2"	3" NPT	2" NPT	

WEIGHT - 60 LBS

**PARTS LIST**

ITEM	DESCRIPTION	MATERIAL
1.	BODY	316 STAINLESS STEEL
2.	COVER	316 STAINLESS STEEL
3.	CAGE	316 STAINLESS STEEL
4.	SEAT	316 STAINLESS STEEL
5.	PLUG	316 STAINLESS STEEL
6.	CONNECTOR	316 STAINLESS STEEL
7.	STUD	316 STAINLESS STEEL
8.	UNIVERSAL COUPLING	316 STAINLESS STEEL
9.	FLOAT ROD	316 STAINLESS STEEL
10.	FLOAT HOOD	316 STAINLESS STEEL
11.	COVER BOLT	316 STAINLESS STEEL
12.	FLOAT BALL	316 STAINLESS STEEL
13.	COVER O-RING	BUNA-N RUBBER
14.	RENEWABLE SEAT	BUNA-N RUBBER
15.	CAGE O-RING	BUNA-N RUBBER
16.	PIPE PLUG, 1/2"	316 STAINLESS STEEL
17.	PIPE PLUG, 1"	316 STAINLESS STEEL
18.	PIPE PLUG, 2"	316 STAINLESS STEEL
19.	HEX NUT	304 STAINLESS STEEL
20.	SPRING PIN	316 STAINLESS STEEL
21.	BUSHING	316 STAINLESS STEEL
22.	LOCK WASHER	410 STAINLESS STEEL
23.	FLOAT SCREW	304 STAINLESS STEEL

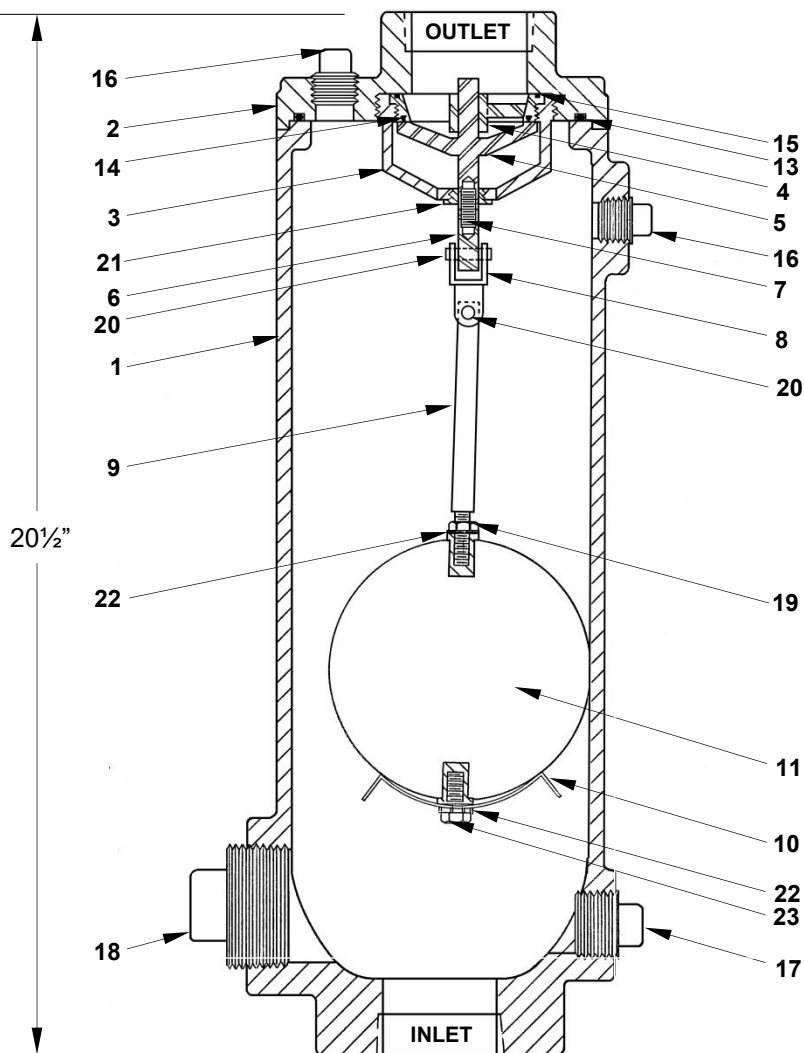

NOTE: VALVE SHOWN IN CLOSED POSITION

**GA INDUSTRIES, a GF+ Brand**

DATE:	3-8-09	DRAWN BY:	WJN
-------	--------	-----------	-----

**DUROVENT™ ALL STAINLESS STEEL  
SEWAGE AIR & VACUUM VALVE**

<b>FIGURE 935SS</b>	DRAWING NO. <b>EAV7105S-W</b>	REV <b>B</b>
---------------------	----------------------------------	-----------------