

SIZE	INLET	AIR & VACUUM OUTLET	AIR RELEASE OUTLET	AIR RELEASE DRAWING	AIR & VACUUM DRAWING	A	B	C	D	E	WEIGHT
4"	4" ANSI CLASS 125	4" NPT	½" NPT	EAR7008	EAV7119	17"	36"	9-1/2"	8-3/4"	11-3/4"	320 lbs.
6"	6" ANSI CLASS 125	6" NPT	½" NPT	EAR7008	EAV7119	22"	38"	13-1/2"	10-1/2"	14"	450 lbs.

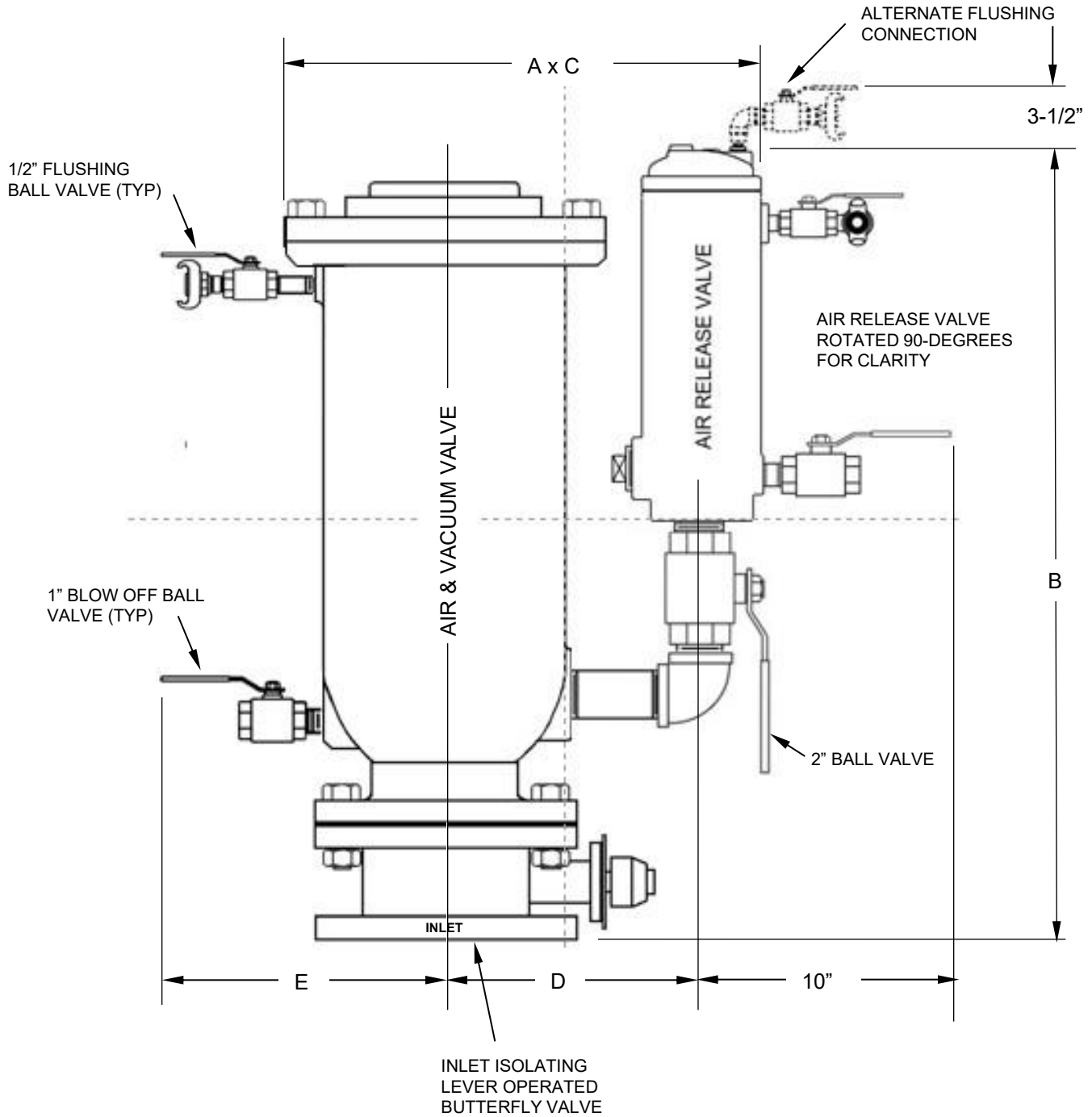

DIMENSIONS AND WEIGHTS ARE APPROXIMATE

FIGURE NUMBER	AIR RELEASE ORIFICE	MAX. WORKING PRESSURE	RATED PRESSURE	HYDRO TEST PRESSURE
955FL-D	0.313" DIA.	75 PSI	200 PSI	300 PSI
955F-D	0.188" DIA.	150 PSI		

<b>GA INDUSTRIES</b> a +GF+ Brand		
DATE: 2/14/09	DRAWN BY: WJN	
<b>4" &amp; 6" FLANGED DUAL BODY WASTEWATER COMBINATION AIR VALVE WITH FLUSHING ATTACHMENTS</b>		
<b>FIGURES 955F-D, 955LF-D</b>		DRAWING NO. <b>ECAV-7130FW</b> REV <b>A</b>