

**PARTS LIST**

ITEM	DESCRIPTION	MATERIAL
1.	FIGURE F990-D VACUUM BREAKING VALVE	DRAWING EAV-7057W
2.	FIGURE 920 AIR RELEASE VALVE	DRAWING EAR-7003W
3.	PIPE NIPPLE	BRASS

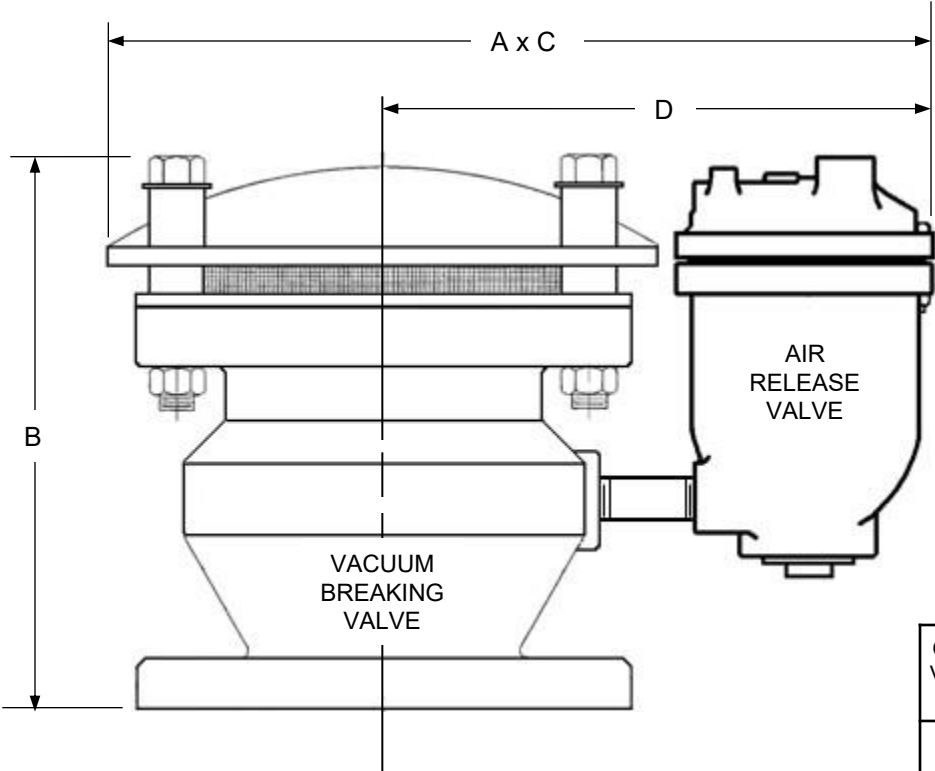

COMBINATION VALVE FIGURE NUMBER	VACUUM BREAKING VALVE	AIR RELEASE VALVE	MAX WORKING PRESSURE	FLANGE	PRESSURE RATING	HYDRO TEST PRESSURE
<b>F992-D</b>	FIGURE F990-D	FIGURE 920	150 PSI	ANSI B16.42 CLASS 150	300 PSI	450 PSI
<b>F992H-D</b>		FIGURE 920H	300 PSI			

SIZE	2-1/2"	3"	4"	6"	8"	10"	12"
A	8"	8"	10"	12"	14"	18"	20"
B	14 3/4"	15"	15 3/4"	17"	18 1/2"	22 1/4"	22"
C	17"	17"	19"	20"	23"	28"	31"
D	13"	13"	14"	14"	16"	19"	21"
WGT	62 lbs.	68 lbs.	86 lbs.	115 lbs.	175 lbs.	245 lbs.	380 lbs.

<b>GA INDUSTRIES</b> a +GF+ Brand		
DATE: 6-4-26	DRAWN BY: WJN	
<b>2-1/2" to 12" COMBINATION VACUUM BREAKING AND AIR RELEASE VALVE</b>		
<b>FIGURE F992</b>	DRAWING NO. <b>ECAV-7159W</b>	REV <b>B</b>