

Dimensions in inches and are approximate; if critical request certified drawing
 Approximate weight 306 lbs.
 Maximum Pressure 300 PSI at 150F
 Maximum Temperature 200F
 Flanges per ANSI B16.42 Class 150
 Flange drilling mates with ANSI B16.1 Class 125

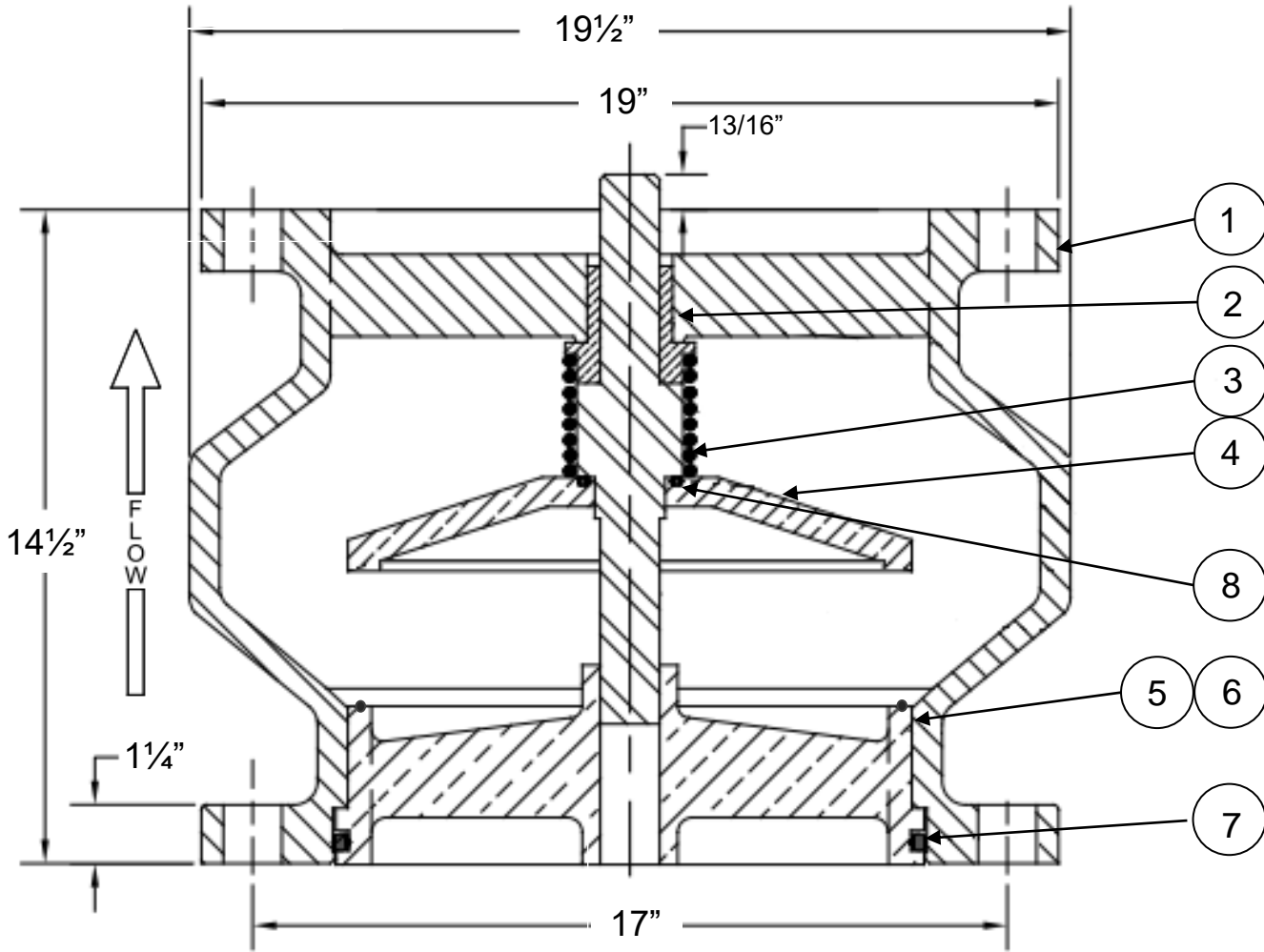

Item	Description	Material	Specification
1	Body	Ductile Iron*	ASTM A535 65-45-12
2	Bushing	Lead Free Bronze	C95400
3	Spring	Stainless Steel	Type 302
4	Poppet	Lead Free Bronze	C87600 or C87800
5	Seat Ring	Lead Free Bronze	C87600 or C87800
6**	O-Ring	Rubber	EPDM
7	O-Ring	Rubber	EPDM
8	O-Ring	Rubber	EPDM

* Fusion bond epoxy lined and coated

** Item 6 not used in metal-to-metal seated valves

GA INDUSTRIES, a VAG Brand		
DATE: 10-3-21	DRAWN BY: WJN	
12" Figure F280 Globe Silent Check Valve		
	DRAWING NO. C-7023-3F	REV