

INSTALLATION, OPERATION AND MAINTENANCE MANUAL

3” to 12” Figure 240-D, Drawing C-7058 4” & 6” Figure 242-D, Drawing C- 7057 Flanged Ball Check Valves

TABLE OF CONTENTS

Introduction	1
Description of Operation	1
Receiving & Storage	1
Installation	1
Valve Construction	1
Start-Up	2
Preventive Maintenance	2
Trouble Shooting	2
Disassembly	2
Assembly	2
Replacement Parts List	2
Warranty	2
Assembly Drawing/Parts Location	3



234 Clay Avenue • Mars, PA 16046 USA
Telephone (724) 776-1020 • Fax (724) 776-1254
E-mail: info-ga@vag-group.com

Manual Number BCV-IOM-052725



WARNING: Cancer and Reproductive Harm – www.Prop65Warnings.ca.gov

INSTALLATION, OPERATION and MAINTENANCE

Figures 240-D and 242-D Flanged Ball Check Valves

INTRODUCTION

This manual will provide the information to properly install, operate and maintain the valve to ensure a long service life. GA Industries Ball Check Valves are ruggedly constructed to provide years of trouble-free operation with minimal maintenance.

CAUTION

The valve is NOT recommended for use with toxic or highly corrosive fluids, fuels or fluids containing hazardous gases

The Shop Order (SO) Number, Figure Number, size and pressure rating are stamped on a nameplate attached to the valve. Please refer to the SO number when ordering parts.

DESCRIPTION OF OPERATION

The Figure 240-D and 242-D Ball Check Valves have only one moving part, the rubber coated ball and are typically installed on the discharge of submersible wastewater pumps. The valve opens when inlet pressure exceeds outlet pressure. Forward flow pushes the ball up an internal guide ramp toward the cover and away from the seat. Flow through the valve tends to "spin" the ball thereby shedding solids and stringy material that would otherwise collect. At pump shutdown, the ball will roll down the ramp and seal the inlet to prevent reverse flow through the valve.

RECEIVING AND STORAGE

Inspect the valve upon receipt for damage during shipment. Carefully unload all valves to the ground without dropping.

The valves should remain in a clean, dry and weather protected area until installed. For long term storage (greater than 6 months) the rubber surfaces of the ball should be coated with a non-toxic lubricant such as "SuperLube" made by Synco Chemical. Do not expose the rubber parts to sunlight or ozone.

INSTALLATION

Figure Numbers suffixed with "D" indicated the valve has ANSI Class 125 flanged connections that will mate to either Class 125 or Class 150 flanges.

Consult the drawings of record to verify the configuration supplied and installed.

Prior to installation ensure all debris, packing material or other foreign material has been removed from both ports.

The preferred installation is in a vertical pipe with upward flow where the ball will seat of its own weight. If installed in a horizontal pipe, the cover must be on top with at least 20 ft. (approximately 9 PSI) of static head at the valve outlet to ensure a tight seal. The valve can be installed in the wetwell, above or below the water, or in a separate valve vault.

The recommended velocity range is 3 to 5 ft/sec, and the maximum working pressure is 150 PSI.

Install the valve in the proper flow direction. Forward flow should tend to open the valve.

If installed outdoors, below ground in a vault or in an unheated area, adequate freeze protection must be provided.

Adequate isolating valves should be installed between the valve and the pipeline or system to facilitate maintenance.

The valve is not designed to support adjacent equipment, piping loads should not be imposed on the valve and large valves should be properly supported. Ensure mating flanges are square and parallel to the valve flanges before tightening flange bolts.

The valve's flat-faced flanged valves should be mated with flat-faced flanges and full-face gaskets. If ring gaskets are used the bolt material shall be ASTM A307 Grade B (or equivalent). Higher strength bolting should only be used with full-face gaskets.

The valves are heavy and cumbersome. Lower heavy valves using slings or chains around the valve body. Lubricate the bolts or studs and insert around flange. Lightly tighten bolts until gaps are eliminated. Torque bolts in an alternating pattern in graduated steps. If leakage occurs wait 24 hours and re-torque the bolts but do not compress the gasket more than 50% or exceed bolt maximum torque rating.

VALVE CONSTRUCTION

GA Industries ball check valves have a cast iron body and a bolted cast iron cover. The ball has a metal core with a Buna-N (nitrile) rubber coating that is

compatible with domestic wastewater that may also contain petroleum-based oils, grease and solvents. Consult factory for compatibility with other fluids. Refer to the List of Materials submitted for the order if non-standard materials were provided.

Refer to Page 3 for details of construction and parts location.

START-UP

The valve does not require any calibration or adjustment prior to start-up. The ball is weighted to accommodate most operating conditions.

The valve opens as flow through the valve increases.

Shut down the pump and observe the valve's closure. Non-slam operation is achieved when the ball seats before flow reversal.

PREVENTIVE MAINTENANCE

GA Industries Ball Check Valves require no scheduled lubrication, adjustment or preventive maintenance.

A monthly visual inspection should be performed for the first 3 months of operation to ensure the valve is functioning properly and there is no external fluid leakage or audible evidence of water leaking backwards through the closed valve.

Thereafter, an annual visual inspection should be performed.

TROUBLESHOOTING

- Leakage past ball when closed
 - Damage to rubber coating on ball
 - Replace ball
 - Foreign matter lodge between ball and seat
 - Clean
- Leakage past cover or flange gaskets
 - Damaged gasket or loose bolts
 - Replace gasket, tighten bolts
- Noisy operation or slam upon pump shutdown
 - Excessive fluid velocity
 - Trapped air

WARNING

Removing the valve from the line or disassembling the valve while there is pressure in the valve body may result in injury or damage to the valve

WARNING

Follow all applicable safety regulations and codes and read and understand all instructions before undertaking disassembly.

DISASSEMBLY

It may be necessary to disassemble the valve because debris is obstructing the valve's operation or to inspect for wear.

All GA Industries Ball Check Valves can be serviced while the body remains connected to the pipeline. A skilled technician should perform all work. No special tools are required.

First ensure there is no pressure within the valve and operating equipment is tagged and locked out. Refer to page 3 for parts identification and location.

1. Ensure there is no pressure within the valve and operating equipment is locked out.
2. Loosen and remove the cover fasteners (4).
3. Remove the cover (2). It may be necessary to pry off the cover. If valve is installed in vertical pipe, support the cover while removing to avoid personnel injury.
4. Carefully lift out the ball.
5. Inspect the ball for wear, tears and abrasion. Clean or replace if needed.
6. Inspect the seating surface in the body for damage.
7. Clean the gasket surfaces of the body and cover.

ASSEMBLY

The valve is reassembled by reversing the disassembly sequence using new or existing parts.

REPLACEMENT PARTS

Genuine replacement parts are available from your local VAG/GA Industries representative or from the factory:

VAG USA, LLC
 234 Clay Avenue
 Mars, PA 16046 USA
 Telephone: 724-776-1020
 Fax: 724-776-1254
 E-mail: quotes-ga@vag-group.com

Please have the nameplate data available when ordering parts. Identify needed part(s) by Shop Order (SO) Number, Figure Number, valve size and individual part number.

REPAIR KITS

Soft Goods Kit includes Items #6 and #7

Size	Kit Number	Part Number
3" Fig 240	BC3	2-80-15000-004
4" Fig 242	BC4-242	2-80-15000-006
4" Fig 240	BC4	2-80-15000-005
6" Fig 242	BC6-242	2-80-15000-008
6" Fig 240	BC6	2-80-15000-007
8" Fig 240	BC8	2-80-15000-009
10" Fig 240	BC10	2-80-15000-000
12" Fig 240	BC12	2-80-15000-002

WARRANTY:

The Warranty for GA Industries valves is included in our Terms and Conditions which can be found here: <https://gaindustries.com/terms>

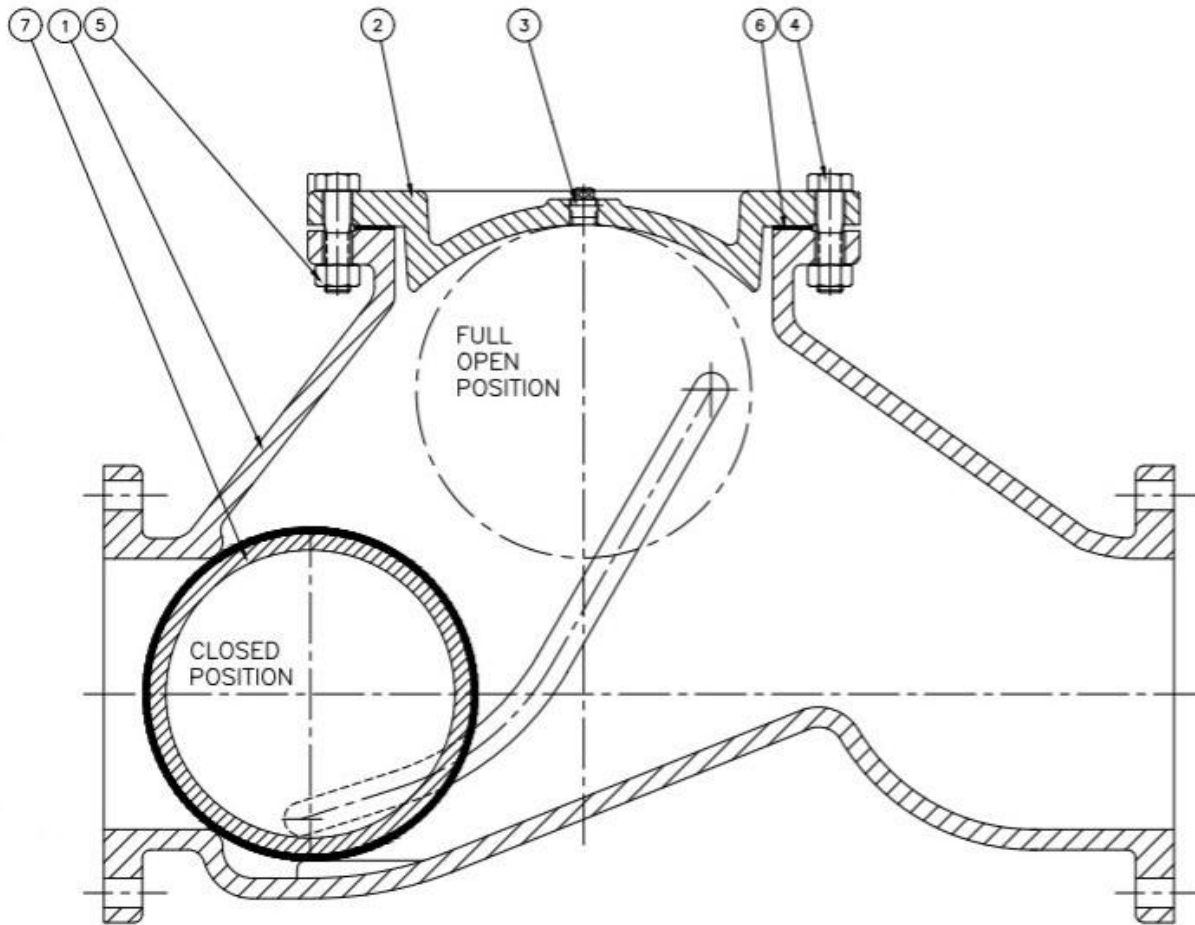

Figure 240-D and 242-D

Standard Materials of Construction

1.	Body	Cast Iron
2.	Cover	Cast Iron
3.	Pipe Plug	Malleable Iron or Steel
4.	Cover Bolts	Zinc Plated Steel (Standard) 316 Stainless Steel (Optional)
5.	Cover Nuts	Zinc Plated Steel (Standard) 316 Stainless Steel (Optional)
6.	Cover Gasket	Composition
7.	Ball	Aluminum or Steel Core, Buna-N Coated

