

# INSTALLATION, OPERATION AND MAINTENANCE MANUAL

## Figures 250-DOC and 250-UOC Drawing C-1092, 2” to 20” Oil-Cushioned Lever & Weight Swing Check Valves

### TABLE OF CONTENTS

Introduction .....	1
Description of Operation .....	1
Receiving & Storage .....	1
Installation .....	1
Valve Construction .....	2
Start-Up .....	2
Preventive Maintenance .....	2
Trouble Shooting .....	2
Disassembly .....	2
Assembly .....	3
Replacement Parts .....	4
Warranty .....	4
Parts List .....	4
Assembly Drawing/Parts Location ....	5



234 Clay Avenue • Mars, PA 16046 USA  
Telephone (724) 776-1020 • Fax (724) 776-1254  
E-mail: [info-ga@vag-group.com](mailto:info-ga@vag-group.com)



WARNING: Cancer and Reproductive Harm – [www.Prop65Warnings.ca.gov](http://www.Prop65Warnings.ca.gov)

# INSTALLATION, OPERATION and MAINTENANCE

## Figures 250-DOC and 250-UOC Oil-Cushioned Lever & Weight Swing Check

### INTRODUCTION

This manual will provide the information to properly install, operate and maintain the valve to ensure a long service life. The Figure 250 Swing Check Valve is ruggedly constructed to provide years of trouble-free operation with minimal maintenance.

### CAUTION

The valve is NOT recommended for use with toxic or highly corrosive fluids, fuels or fluids containing hazardous gases

The Shop Order (SO) Number, Figure Number, size and pressure rating are stamped on a nameplate attached to the valve. Please refer to the SO number when ordering parts.

### DESCRIPTION OF OPERATION

The Figure 250-DOC and 250-UOC Swing Check Valves are an oil-cushioned, counter-weighted rubber-seated check valve designed to permit flow in one direction and close to prevent reverse flow. The valve opens when the inlet pressure exceeds the outlet pressure. The degree of opening depends on the fluid velocity through the valve. The valve will swing closed as fluid velocity decreases and be fully seated before flow reversal precluding slam and bang. The valve employs a hydraulic "shock absorber" as an oil cushion to dampen the valve's rapid closure.

### RECEIVING AND STORAGE

Inspect the valve upon receipt for damage during shipment. Carefully unload all valves to the ground without dropping.

The valves should remain in a clean, dry and weather protected area until installed. For long term storage (greater than 6 months) the rubber surfaces of the seat should be coated with a non-toxic lubricant such as "SuperLube" made by Synco Chemical. Do not expose the rubber parts to sunlight or ozone.

### INSTALLATION

The "D" in the Figure Number indicates the valve has ANSI Class 125 flanged connections. Figure Numbers with a "U" indicate the valve has ANSI Class 250 flanged connections. An "A" in the Figure

Number (e.g., 250-DAOC, 250-UAOC) indicates the valve is configured for installation in a vertical pipe.

Consult the drawings of record to verify the configuration supplied and installed.

Prior to installation ensure all debris, packing material or other foreign material has been removed from both ports.

The valve can be installed in a horizontal or vertical (upward flow direction) pipe. In either case the counterweight arm must be horizontal when the valve is closed.

Install the valve in the proper flow direction. Forward flow should tend to open the valve.

If installed outdoors, below ground in a vault or in an unheated area, adequate freeze protection must be provided.

Adequate isolating valves should be installed between the valve and the pipeline or system to facilitate maintenance.

Installation immediately downstream of an elbow or a significant increase in pipe size may produce uneven or turbulent flow through the valve and lead to premature wear. Consult factory for recommendations

The valve is not designed to support adjacent equipment, piping loads should not be imposed on the valve and large valves should be properly supported. Ensure mating flanges are square and parallel to the valve flanges before tightening flange bolts.

Flat-faced flanged valves should be mated with flat-faced flanges and full-face gaskets. If ring gaskets are used the bolt material shall be ASTM A307 Grade B (or equivalent). Higher strength bolting should only be used with full-face gaskets.

Lower heavy valves using slings or chains around the valve body and/or the lifting eye. Lubricate the bolts or studs and insert around flange. Lightly tighten bolts until gaps are eliminated. Torque bolts in an alternating pattern in graduated steps. If leakage occurs wait 24 hours and re-torque the bolts but do

not compress the gasket more than 50% or exceed bolt maximum torque rating.

### VALVE CONSTRUCTION

The standard Figure 250-DOC and 250-UOC Swing Check Valves have a cast iron body, stainless steel body seat (older valves may have a bronze body seat), stainless steel hinge shaft and cast iron disc with a rubber disc seat. Refer to the List of Materials submitted for the order if non-standard materials were provided.

Refer to Page 5 for details of construction and parts location.

### START-UP

The valve generally does not require any calibration or adjustment prior to start-up. The counterweight(s) should be initially placed at the far end of the arm and secured by tightening the set screw (31A).

The valve should smoothly swing open as flow through the valve increases. The amount of opening depends on the flow velocity through the valve and can be observed by watching the external counterweight arm. The valve is "full ported" at about 25 degrees of swing but can swing open as much as 60 degrees.

Shut down the pump and observe the valve's closure. If the valve was less than 60 degrees open and the closure was smooth and quiet, then the weight(s) may be moved incrementally toward the shaft. Repeat these steps to the point where the valve opens to the extent possible but still closes quietly.

The air-cushion chamber cannot retard the valve's closure or prevent the valve from being slammed shut due to the tremendous forces of the reversing water. Non-slam operation is achieved when the counterweight closes the valve prior to flow reversal. In extreme cases, it may be necessary to install additional counterweight(s) to effect non-slam closure.

The oil cushion chamber will minimize the slam tendency when the valve closes too quickly due to its own counterweight action.

### PREVENTIVE MAINTENANCE

Figure 250-DOC and 250-UOC Swing Check Valves require no scheduled lubrication, adjustment or preventive maintenance.

A monthly inspection should be performed for the first 6 months of operation to ensure the valve is functioning properly and there is no external fluid leakage or audible evidence of water leaking backwards through the closed valve.

Thereafter, a quarterly visual inspection should be performed.

### TROUBLESHOOTING

- Shaft packing leakage  
Tighten packing gland nuts equally just enough to stop leakage, no more than ½ turn at a time. DO NOT OVER-TIGHTEN!  
Replace packing if necessary.
- Leakage past seat when closed  
Inspect valve for debris, clean  
Inspect seating surfaces for damage, replace as necessary
- Leakage past cover or flange gaskets  
Tighten cover or flange bolts
- Disc oscillating when open  
Move counterweight(s) toward shaft
- Valve slams upon closing  
Move counterweight(s) toward end of arm  
Ensure shaft packing is not too tight  
Install additional counterweight(s)

#### WARNING

Removing the valve from the line or disassembling the valve while there is pressure in the valve body may result in injury or damage to the valve

#### WARNING

Follow all applicable safety regulations and codes and read and understand all instructions before undertaking disassembly.

### DISASSEMBLY

All Figure 250-DOC and 250-UOC valves can be serviced while the body remains connected to the pipeline. A skilled technician should perform all work. No special tools are required.

First ensure there is no pressure within the valve and operating equipment is tagged and locked out. Refer to page 4 for parts identification.

It is not necessary to disassemble the entire valve to replace the shaft packing, follow steps 1 to 3. To install packing follow steps 5a and 6a.

To move counterweight and shock absorber to left hand side of valve, disassemble valve through Step 7. Remove shock absorber bracket screws (21) and shock absorber and install on opposite side of valve.

1. Ensure there is no pressure within the valve and operating equipment is locked out.
2. Mark the position of the counterweight(s) on the arm. Loosen the counterweight set screw (28) and slide the weight(s) off the arm. Loosen the counterweight arm set screws (26) and slide the arm (24) off the shaft, being careful not to lose the key (25).
3. Loosen and remove the gland bolts (23), slide off the gland (21) and remove the gland packing (22).
4. Remove the end plate bolts (38), the end plate (37) being careful not to lose or damage the end plate seal (39) unless it is to be replaced

5. Remove the cover fasteners (14) and lift off the cover (13). If necessary, carefully pry the cover off using a cold chisel between the body and cover. Be careful not to damage or lose the cover gasket (12) unless it is to be replaced.
6. Remove the shaft lock pin (18) by threading a screw into the tapped hole.
7. With the disc and disc arm properly supported, loosen the disc arm set screw (16) and pull the shaft (17) out of the valve. It may be necessary to drive out the shaft from the opposite end.  
NOTE: The outer bushing (20) and shaft key (15) should come out with the shaft. Be careful not to lose the disc arm key. After the shaft is out, remove the inner bushing (19) from the opposite side.
8. Carefully lift the disc arm assembly out of the body. Remove the disc nut cotter pin (35), disc nut (11) and disc nut washer (34).
9. Remove the seat follower screws (10), the seat follower (9) and the renewable seat (8).
10. In the unlikely event it's necessary to remove the body seat (2), the spring pins holding it into the body must be compressed until they no longer "bite" into the body. This is best accomplished by compressing the seat pins (4) using "vice-grips" and pulling the pins in a radial direction towards the valve centerline.

Inspect all parts for wear and damage. Replace damaged parts.

#### ASSEMBLY

The valve is reassembled by reversing the disassembly sequence with consideration of the following:

- 1a. Clean and polish all machined bearing and sealing surfaces. Apply a light coat of lubricant to assist in the assembly.
- 2a. Ensure the disc arm key slides inside the disc arm before installing the shaft lock pin (18). Ensure the shaft lock pin has dropped into the groove provided for it on the shaft.  
NOTE: If re-assembling with counterweight and shock absorber on left hand size, shaft lock pin is installed in hole on right side of valve, looking at the inlet.
- 3a. Lift the disc assembly several times to ensure free closure with no metal-to-metal contact.
- 4a. Install the inner and outer bushings then install the shaft packing. Install the end plate (37) with seal (39). Install and tighten the end plate screws (38) while ensuring the end plate seal (39) remains in the groove provided for it in the end plate
- 5a. Wrap the packing around the shaft and cut on a 45-degree angle, staggering the cuts with each ring.

- 6a. Tighten gland bolts evenly until packing is slightly compressed. After pressure has been introduced into the valve, re-tighten evenly until leakage stops.
- 7a. Ensure cover gasket sealing surfaces are clean and apply a thin coat of Permatex™ #2 to both surfaces. Tighten cover nuts in an alternating pattern. Re-tighten as needed after pressure has been introduced.
- 8a. Re-install the counterweight arm (24) with key (25) and tighten counterweight set screws (26).
- 11a. Slide counterweight(s) (27) onto shaft and lock in place using set screws (28). Lift counterweight arm and allow it to fall to ensure free movement.
11. Install shock absorber bracket and shock absorber.

#### REPLACEMENT PARTS

Genuine replacement parts are available from your local VAG/GA Industries representative or from the factory:

VAG USA, LLC  
234 Clay Avenue  
Mars, PA 16046 USA  
Telephone: 724-776-1020  
Fax: 724-776-1254  
E-mail: [quotes-ga@vag-group.com](mailto:quotes-ga@vag-group.com)

Please have the nameplate data available when ordering parts. Identify needed part(s) by Shop Order (SO) Number, Figure Number, valve size and individual part number.

#### REPAIR KITS

Soft Goods Kit includes Items 2A 5A, 8, 17 & 36

Size	Kit Number	Part Number
2" to 3"	SW3	2-80-24000-218
4"	SW4	2-80-24000-222
6"	SW6	2-80-24000-225
8"	SW8	2-80-24000-228
10"	SW10	2-80-24000-200
12"	SW12	2-80-24000-203
14"	SW14	2-80-24000-206
16"	SW16	2-80-24000-209
18" & 20"	SW1820	2-80-24000-212

Soft Goods AND Disc/Disc Arm Assembly Kit includes above parts plus Items 3, 4, 5B, 5C, 6, 6A, 6B & 12.

Size	Kit Number	Part Number
2" to 3"	SW3D	2-80-24000-221
4"	SW4D	2-80-24000-224
6"	SW6D	2-80-24000-227
8"	SW8D	2-80-24000-230
10"	SW10D	2-80-24000-202
12"	SW12D	2-80-24000-205
14"	SW14D	2-80-24000-208
16"	SW16D	2-80-24000-211
18" & 20"	SW1820D	2-80-24000-213

All other parts ordered individually. Consult factor for larger sizes

**WARRANTY:**

The Warranty for GA Industries valves is included in our Terms and Conditions which can be found here: <https://gaindustries.com/terms>

**PARTS LIST**

<b>Part No.</b>	<b>Part Name</b>	<b>Std. Material</b>
1	Body	Cast Iron
2	Body Seat	SS (or Bronze)
3	Seat O-Ring	Rubber
4	Seat Pins	Stainless Steel
5	Disc	Cast Iron
6	Disc Center Pin	Steel or SS
7	Disc Arm	Ductile Iron
8	Renewable Seat	Rubber
9	Seat Follower	Stainless Steel
10	Seat Follower Screws	Stainless Steel
11	Disc Nut	Steel or SS
12	Cover Gasket	Composition
13	Cover	Steel
14	Cover Fasteners	Steel or SS
15	Shaft Key	Stainless Steel
16	Disc Arm Set Screw	Stainless Steel
17	Shaft	Stainless Steel
18	Shaft Lock Pin	Brass or SS
19	Inner Bushing	Bronze
20	Outer Bushing	Bronze
21	Gland	Cast Iron
22	Packing	Teflon
23	Gland Bolts	Steel or SS
24	Counterweight Arm	Ductile Iron/Steel
25	Counterweight Arm Key	Stainless Steel
26	C'weight Arm Set Screw	Stainless Steel
27	Counterweight(s)	Cast Iron
28	Counterweight Set Screw	Stainless Steel
29	Shock Absorber Bracket	Steel
30	Bracket Screws	Steel
31	Bracket Pins	Steel
32	Hydraulic Shock Absorber	Commercial
33	Lock Nut	Commercial
34	Disc Nut Washer	Steel or SS
35	Disc Nut Cotter Pin	SS
37	Shaft End Plate	Steel
38	End Plate Screws	Steel or SS
39	End Plate Seal	Rubber

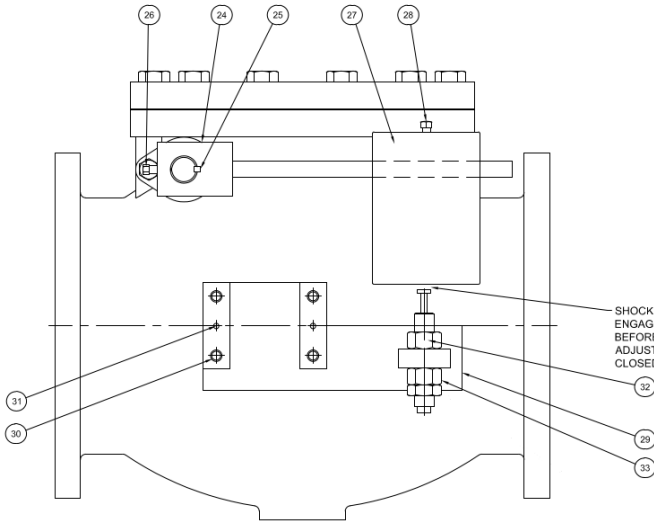
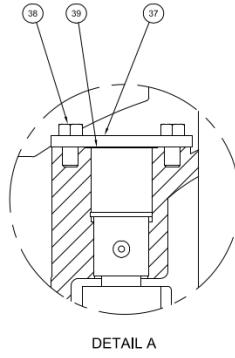
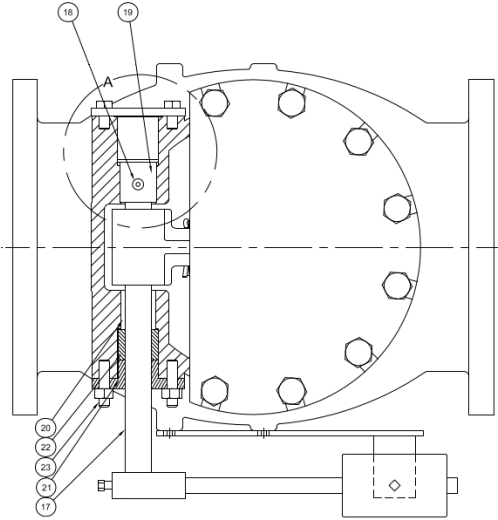

SHOCK ABSORBER MUST NOT  
ENGAGE COUNTERWEIGHT  
BEFORE VALVE IS SEATED.  
ADJUST FOR 1/16" GAP IN  
CLOSED POSITION

FLOW

