

INSTALLATION, OPERATION AND MAINTENANCE MANUAL

LUDLOW SERIES **FIGURE 340-W**

3” to 30” Drawing C-1366 Lever & Weight Swing Check Valves

TABLE OF CONTENTS

Introduction	1
Description of Operation	1
Receiving & Storage	1
Installation	1
Valve Construction	1
Start-Up	1
Preventive Maintenance	2
Trouble Shooting	2
Disassembly	2
Assembly	2
Assembly Drawing/Parts Location	3
Warranty	4



234 Clay Avenue • Mars, PA 16046 USA
Telephone (724) 776-1020 • Fax (724) 776-1254
E-mail: info-ga@vag-group.com



WARNING: Cancer and Reproductive Harm – www.Prop65Warnings.ca.gov

INSTALLATION, OPERATION and MAINTENANCE

Figure 340-W Swing Check

INTRODUCTION

This manual will provide the information to properly install, operate and maintain the valve to ensure a long service life. The Figure 340-W Lever & Weight Swing Check Valve is ruggedly constructed to provide years of trouble-free operation with minimal maintenance.

CAUTION

The valve is NOT recommended for use with toxic or highly corrosive fluids, fuels or fluids containing hazardous gases

The Shop Order (SO) Number, Figure Number, size and pressure rating are stamped on a nameplate attached to the valve. Please refer to the SO number when ordering parts.

DESCRIPTION OF OPERATION

The Figure 340-W Swing Check Valve is a counter-weighted rubber-seat check valve designed to permit flow in one direction and close to prevent reverse flow. The valve opens when the inlet pressure exceeds the outlet pressure. The degree of opening depends on the fluid velocity through the valve. The valve will swing closed as fluid velocity decreases and be fully seated before flow reversal precluding slam and bang.

RECEIVING AND STORAGE

Inspect the valve upon receipt for damage during shipment. Carefully unload all valves to the ground without dropping.

The valves should remain in a clean, dry and weather protected area until installed. For long term storage (greater than 6 months) the rubber surfaces of the seat should be coated with a non-toxic lubricant such as "SuperLube" made by Synco Chemical. Do not expose the rubber parts to sunlight or ozone.

INSTALLATION

The Figure 340-W is standard with ANSI Class 125 flanged connections.

Consult the drawings of record to verify the configuration supplied and installed.

Prior to installation ensure all debris, packing material or other foreign material has been removed from both ports.

The valve is designed to be installed in a horizontal pipe. The counterweight arm must be horizontal when the valve is closed.

Install the valve in the proper flow direction.

If installed outdoors, below ground in a vault or in an unheated area, adequate freeze protection must be provided.

Adequate isolating valves should be installed between the valve and the pipeline or system to facilitate maintenance.

The valve is not designed to support adjacent equipment, piping loads should not be imposed on the valve and large valves should be properly supported. Ensure mating flanges are square and parallel to the valve flanges before tightening flange bolts.

Flat-faced flanged valves should be mated with flat-faced flanges and full-face gaskets. If ring gaskets are used the bolt material shall be ASTM A307 Grade B (or equivalent). Higher strength bolting should only be used with full-face gaskets.

Lower heavy valves using slings or chains around the valve body and/or the lifting eye. Lubricate the bolts or studs and insert around flange. Lightly tighten bolts until gaps are eliminated. Torque bolts in an alternating pattern in graduated steps. If leakage occurs wait 24 hours and re-torque the bolts but do not compress the gasket more than 50% or exceed bolt maximum torque rating.

VALVE CONSTRUCTION

The standard Figure 340-W Lever & Weight Check Valve has a ductile iron body and cover, stainless steel body seat, stainless steel hinge shaft and ductile iron disc with a rubber disc seat. Refer to the List of Materials submitted for the order if non-standard materials were provided.

Refer to Page 3 for details of construction and parts location.

START-UP

The valve does not require any calibration or adjustment prior to start-up. The counterweight(s) should be initially placed at the far end of the arm and secured by tightening the set screw (31A).

The valve should smoothly swing open as flow through the valve increases. The amount of opening depends on the flow through the valve and can be observed by watching the counterweight arm. The valve is "full ported" at about 25 degrees of swing but can swing open as much as 60 degrees.

Shut down the pump and observe the valve's closure. If the valve was less than 60 degrees open and the closure was smooth and quiet, move the weight(s) incrementally toward the shaft. Repeat to the point where the valve opens to the extent possible but still closes quietly.

If the counterweight is at the end of the arm yet the valve does not close quietly it may be necessary to add another counterweight.

PREVENTIVE MAINTENANCE

Figure 340-W Lever & Weight Swing Check Valves require no scheduled lubrication, adjustment or preventive maintenance.

A monthly inspection should be performed for the first 6 months of operation to ensure the valve is functioning properly and there is no external fluid leakage or audible evidence of water leaking backwards through the closed valve.

Thereafter, a quarterly visual inspection should be performed.

TROUBLESHOOTING

- Shaft packing leakage
Tighten packing gland nuts equally just enough to stop leakage, no more than 1/2 turn at a time. Replace packing if necessary.
- Leakage past seat when closed
Inspect valve for debris, clean
Inspect seating surfaces for damage, replace as necessary
- Leakage past cover or flange gaskets
Tighten cover or flange bolts
- Disc oscillating when open
Adjust counterweight inward along arm
- Valve slams upon closing
Adjust counterweight outward along arm
Ensure shaft packing is not too tight
Install additional counterweight

WARNING

Removing the valve from the line or disassembling the valve while there is pressure in the valve body may result in injury or damage to the valve

WARNING

Follow all applicable safety regulations and codes and read and understand all instructions before undertaking disassembly.

DISASSEMBLY

All Figure 340-W valves can be serviced while the body remains connected to the pipeline. A skilled technician should perform all work. No special tools are required.

First ensure there is no pressure within the valve and operating equipment is tagged and locked out. Refer to page 3 for parts identification.

It is not necessary to disassemble the entire valve to remove the shaft packing, follow steps 1 to 4 and 4a.

1. Ensure there is no pressure within the valve and operating equipment is locked out.
2. Mark the position of the counterweight(s) on the counterweight arm. Loosen counterweight arm set screw (30A) and slide the counterweight arm (30) and weight (31) off the shaft (11). In large valves it may be necessary to first loosen the counterweight set screws (31A) and remove the counterweight(s) from the arm.
3. Loosen and remove the gland bolts (16) and slide the glands (15) off the shaft (11) on both sides of the valve.
4. Remove the shaft packing (17) from both sides of the valve.
5. Remove the cover nuts (10) and lift off cover (9). It may be necessary to carefully pry the cover off. Be careful not to damage or lose the cover gasket (8) unless it is to be replaced.
6. Remove the shaft lock pin (18) and while supporting the disc arm assembly pull the shaft (11) out of the valve.
NOTE: It may be necessary to tap on the end of the shaft to remove it from the disc arm.
NOTE: The outer bushing (14) and disc arm key (19) should come out with the shaft. Be careful not to lose the disc arm key. After the shaft is out, remove the inner bushing (13) from the opposite side.
7. Carefully lift the disc arm assembly out of the body. Remove the disc nut pin (6B), disc nut (6) and disc nut washer (6A).
8. Disc seat is vulcanized to the disc and cannot be removed. If the rubber disc seat is damaged, the entire disc with vulcanized seat must be replaced.

Inspect all parts for wear and damage. Replace damaged parts.

ASSEMBLY

The valve is reassembled by reversing the disassembly sequence with consideration of the following:

- 1a. Clean and polish all machined bearing and sealing surfaces. Apply a light coat of lubricant to assist in the assembly.
- 2a. Ensure the disc arm key slides inside the shaft before installing the shaft lock pin (18). Ensure the shaft lock pin is centered in the groove provided for it on the shaft. Tighten the shaft lock pin (18) until the shaft will not turn then back off 1/2 turn.
- 3a. Lift the disc assembly several times to ensure free closure with no metal-to-metal contact.
- 4a. Install the inner and outer bushings then install the shaft packing. Wrap the packing around the shaft and cut on a 45-degree angle, staggering the cuts with each ring.
- 5a. Tighten gland bolts evenly until packing is slightly compressed. After pressure has been introduced into the valve, re-tighten evenly until leakage stops.
- 6a. Ensure cover gasket sealing surfaces are clean and apply a thin coat of Permatex™ #2 to both surfaces. Tighten cover nuts in an alternating pattern. Re-tighten as needed after pressure has been introduced.

Part No.	Part Name	Std. Material
1.	Body	Ductile Iron
2.	Body Seat	Bronze or SS
3.	Disc w/Seat	Ductile Iron/Buna N
4.	Disc Arm	Ductile Iron
6.	Disc Nut	Brass
6A.	Disc Nut Washer	Brass
6B.	Disc Pin	Stainless Steel
8.	Cover Gasket	Composition
9.	Cover	Ductile Iron
10.	Cover Stud w/Nut	Steel or SS
10A.	Eye Bolt	Steel or SS
11.	Shaft	Stainless Steel
13.	Inner Bushing	Bronze
14.	Outer Bushing	Bronze
15.	Gland	Ductile Iron
16.	Gland Bolt	Steel
17.	Packing	Teflon
18.	Shaft Lock Pin	Steel
19.	Disc Arm Key	Stainless Steel
30.	3" - 20" Counterweight Arm	Cast Iron/Steel
30A	Counterweight Arm Set Scr.	Steel
30B	Counterweight Arm Key	Stainless Steel
30C	24" Counterweight Arm	Steel
30D	24" Counterweight Arm Scr.	Steel
30E	24" Counterweight Arm Pin	Steel
31.	Counterweight	Cast Iron or Steel
31A.	Counterweight Set Screw	Steel

REPLACEMENT PARTS

Genuine replacement parts are available from your local VAG/GA Industries representative or from the factory:

VAG USA, LLC
 234 Clay Avenue
 Mars, PA 16466 USA
 Telephone: 724-776-1020
 Fax: 724-776-1254
 E-mail: quotes-ga@vag-group.com

Please have the nameplate data available when ordering parts. Identify needed part(s) by Shop Order (SO) Number, Figure 340-W, valve size and Part No.

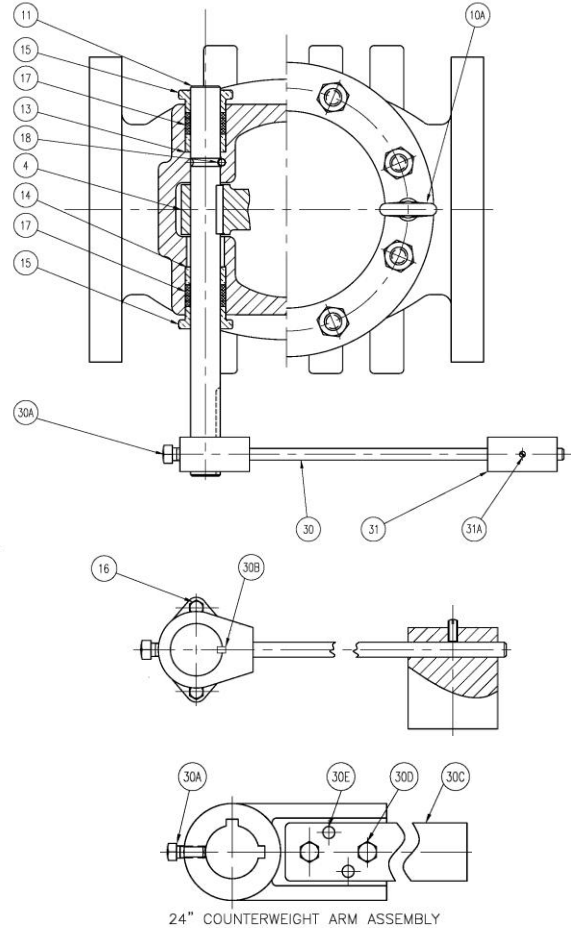
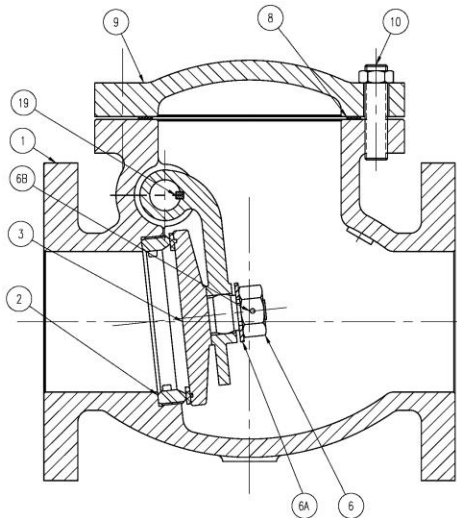

WARRANTY

For a period of one year from the date of shipment, and provided payments for the Products have been made by Buyer to Seller, Seller warrants to Buyer that its Products: (i) substantially conform to Seller's published specifications and (ii) are free from defects in material or workmanship. Specific products may have a warranty period greater than one year. Any Services provided by Seller are warranted to be performed in a good and workmanlike manner. Should a warranted Product or any Services fail to conform to these warranties, Buyer must promptly notify Seller in writing. Seller will, at its discretion and at no charge to the Buyer: (i) repair the Product or Services; (ii) replace the Product or any Services; or (iii) offer a full refund of that portion of the purchase price allocable to the non-conforming Product or Services. Warranty repair or replacement by Seller shall not extend or renew the applicable warranty period. Buyer shall obtain Seller's agreement on the specifications of any tests it plans to conduct to determine whether a non-conformance exists. Buyer shall bear the costs of access for Seller's remedial warranty efforts (including removal and replacement of systems, structures or other parts of Buyer's facility), de-installation, decontamination and re-installation. THE FOREGOING WARRANTIES ARE IN LIEU OF ALL OTHER WARRANTIES, EXPRESS OR IMPLIED, INCLUDING BUT NOT LIMITED TO THE IMPLIED WARRANTIES OF MERCHANTABILITY AND FITNESS FOR A PARTICULAR PURPOSE. This warranty allocates the risks of Product failure between Seller and Buyer. This allocation is recognized by both parties and is reflected in the price of the goods. Buyer acknowledges that it has read VAG USA, LLC's Terms and Conditions of Sale, understands it, and agrees to and is bound by its terms.

WHAT IS NOT COVERED BY WARRANTY

No representative of Seller has authority to waive, alter, vary or add to the terms hereof without prior written approval of an officer of Seller. Seller's warranty does not apply to: (i) dynamic vibrations imposed by the drive system in which such Products are installed unless the nature of such vibrations has been defined and accepted in writing by Company as a condition of operation; (ii) improper or unauthorized repair, installation or maintenance of the Products by a party other than Seller; (iii) use for purposes other than those for which designed, or other abuse, negligence, misuse, or normal wear and tear; (iv) unauthorized attachments, modifications or disassembly; (v) damage during shipping; or (vi) Products purchased from unauthorized distributors, resellers or internet sites. Buyer's care in selection, adequate testing at time of installation and proper installation, operation and maintenance of all Products is required for adequate performance.

LIMITATIONS OF LIABILITY

NOTWITHSTANDING ANY PROVISION OF THIS CONTRACT OR THE LAW, IT IS EXPRESSLY AGREED THAT SELLER'S TOTAL LIABILITY FOR ANY DAMAGES, COSTS OR EXPENSES ARISING OUT OF OR RELATED TO THIS CONTRACT OR ITS PRODUCTS OR SERVICES, WHETHER BASED IN CONTRACT, WARRANTY, INDEMNITY, TORT/EXTRA-CONTRACTUAL LIABILITY (INCLUDING NEGLIGENCE), STRICT LIABILITY OR OTHERWISE IS LIMITED TO THE REPAIR OR REPLACEMENT OF THE PRODUCT OR SERVICES OR, AT SELLER'S OPTION, A RETURN OF AN AMOUNT THAT SHALL NOT EXCEED THE PURCHASE PRICE. UNDER NO CIRCUMSTANCES WILL SELLER, IT'S OFFICERS, DIRECTORS, EMPLOYEES OR ASSIGNS BE LIABLE FOR ANY OTHER REMEDY, LOSS, COST, DAMAGE OR EXPENSE WHETHER DIRECT OR INDIRECT. IN NO EVENT WHATSOEVER SHALL SELLER BE LIABLE FOR ANY CONSEQUENTIAL, LIQUIDATE, EXEMPLARY OR PUNITIVE DAMAGES, INCLUDING BUT NOT LIMITED TO, LOSS OF USE, INCOME, PROFIT, OR PRODUCTION; INCREASED COST OF OPERATION, SPOILAGE OR DAMAGE TO MATERIAL, OR CHANGE OUT COSTS. BUYER SHALL INDEMNIFY, DEFEND AND HOLD SELLER HARMLESS FROM ANY LOSS, COST, EXPENSE, DAMAGE, OR CAUSE OF ACTION TO OR BY A THIRD PARTY THAT EXCEEDS THESE LIMITATIONS OF LIABILITY.