

INSTALLATION, OPERATION AND MAINTENANCE MANUAL

Figure 945

$\frac{1}{2}$ " , $\frac{3}{4}$ " and 1"
Combination Air Valves for Water

Drawing ECAV-7136



VAG USA, LLC
234 Clay Avenue • Mars, PA 16046 USA
Telephone (724) 776-1020 • Fax (724) 776-1254
E-mail: info-ga@vag-group.com

Manual Number 945.1-IOM 022420 Rev A (10-1-20)



WARNING: Cancer and Reproductive Harm – www.Prop65Warnings.ca.gov

INSTALLATION, OPERATION and MAINTENANCE

1" Figure 945 Combination Air Valves

INTRODUCTION

This manual will provide the information to properly install, operate and maintain the valve to ensure a long service life. The Combination Air Valve is ruggedly constructed to provide years of trouble-free operation with minimal maintenance.

Figure 945 Combination Air Valves are not intended for use with fluids containing suspended solids such as wastewater and sewage. GA Industries Figure 942, 955, 957 or 959 Combination Air Valves are recommended for such applications.

CAUTION

The valve is NOT recommended for use with toxic fluids, fuels or fluids containing hazardous gases

CAUTION

The valve will not function if used at a pressure higher than the maximum working pressure indicated on the nameplate.

The Shop Order (SO) Number, Figure Number, size and pressure rating are stamped on a nameplate attached to the valve. Please refer to the SO number when ordering parts.

DESCRIPTION OF OPERATION

The Figure 945 Combination Air Valve performs the following functions:

- Vents air through the large orifice ahead of the incoming water as the system is filled then closes tightly to prevent the escape of water.
- Automatically opens and closes the small orifice as often as needed to release air that has accumulated in the valve while the system is pressurized and operational
- Opens automatically to admit air through the large orifice to limit vacuum pressure within the pipe or system.

RECEIVING AND STORAGE

Inspect the valve upon receipt for damage during shipment. Carefully unload all valves to the ground without dropping.

The valves should remain in a clean, dry and weather protected area until installed. For long term storage (greater than 6 months) the rubber surfaces of the seat should be coated with a non-toxic lubricant such as "SuperLube" made by Synco Chemical. Do not expose the rubber parts to sunlight or ozone.

INSTALLATION

The 1" Figure 945 is standard with NPT screwed connections and reducer bushings are provided for smaller sizes.

Consult the drawings of record to verify the configuration supplied and installed.

The valve must be installed in an upright vertical orientation, normally at a high point in the system.

If installed outdoors, below ground in a vault or in an unheated area, adequate freeze protection must be provided. Some discharge of water may occur during operation so the valve outlet should be piped to an adequate drain.

An isolating valve should be installed between the valve and the pipeline or system to facilitate maintenance.

Carefully screw threaded end valves onto pipe nipple using compatible thread sealant. Tighten valve using wrench flats. DO NOT OVERTIGHTEN.

Flat-faced flanged valves should be mated with flat-faced flanges and full-face gaskets. If ring gaskets are used the bolt material shall be ASTM A307 Grade B (or equivalent). Higher strength bolting should only be used with full-face gaskets.

Lower heavy valves over the mating flange using slings or chains around the valve body. Lubricate the bolts or studs and insert around flange. Lightly tighten bolts until gaps are eliminated. Torque bolts in an alternating pattern in graduated steps. If leakage occurs wait 24 hours and re-torque the bolts but do not compress the gasket more than 50% or exceed bolt maximum torque rating.

The valve is standard with an NPT screwed outlet connection. It is recommended that the outlet be piped away in a manner that directs the high velocity air discharge away from personnel. An optional "cowl" can be provided to deflect the air discharge.

VALVE CONSTRUCTION

The standard Figure 945 Combination Air Valve has an iron body, stainless steel float and linkage mechanism and a rubber seat. Optional materials can be provided so refer to the List of Materials submitted for the order if non-standard materials were provided.

Refer to Figure 1 for details of construction and parts location.

The inlet connection is at the center of the bottom where the valve attaches to the system and the outlet connection through which air leaves the valve is at the opposite end on the rectangular cover

WARNING

Removing the valve from the line or disassembling the valve while there is pressure in the valve body may result in injury or damage to the valve

PREVENTIVE MAINTENANCE

Figure 945 Combination Air Valves require no scheduled lubrication, adjustment or preventive maintenance.

A periodic visual inspection should be performed to ensure the outlet piping is not obstructed and to verify there is no fluid leakage.

TESTING

Valve operation can be easily tested. Close the inlet isolation valve and remove or loosen the pipe plug nearest the inlet to drain the water from the valve. The floats should drop as the water leaves the valve. NOTE: A ball or gate

valve can be installed in place of the pipe plug to facilitate testing.

Replace or tighten the pipe plug and slowly open the inlet isolating valve. The valve should float closed and seat tightly.

TROUBLESHOOTING

- Valve Does Not Close / Fluid Leakage
Verify debris has not collected on the seats preventing tight closure

Verify rubber orifice button and/or orifice seating surfaces are not damaged

Verify floats have buoyancy

Verify linkage mechanism operates freely without binding or sticking

- Valve Does Not Open
Verify debris in the valve is not preventing the floats from freely falling when fluid is drained from valve

Verify linkage mechanism operates freely without binding or sticking

DISASSEMBLY

While small valves may be more easily serviced by removing it from the line, all valves can be serviced while the body remains connected to the pipeline. A skilled technician with proper tools should perform all work. No special tools are required.

First ensure there is no pressure within the valve. Remove the cover bolts (8) and lift off cover (2). It may be necessary to pry off the cover or tap upward with a mallet and cold chisel at the cover/body juncture.

Lift out the air/vacuum float (5), cushion (21) and guide bearing (23) being careful not to drop these small parts. If needed, unscrew the float guide (22) from the float (5).

Remove the spring pin connecting the float arm (14) to the leverage bracket (11). The float and linkage will be free from the cover.

Remove the float screw (18), lockwasher (17) and air release float (13). If the orifice button (10) is to be replaced, remove by breaking it off.

If the orifice (9) and/or leverage bracket (11) is being replaced, use a 1/2" socket to remove the orifice (9). The orifice was factory installed using Loctite® so it may be necessary to apply some heat to remove.

If the large orifice seat is to be replaced, remove the seat screws (6), support ring (4) and seat (3).

Inspect all parts for wear and damage. Minor scratches and dents in the float are normal. Some floats may contain sand for added weight but if water is detected replace the float. Carefully clean the orifice of scale. Remove all vestiges of the cover gasket from the body and cover surfaces. Clean gasket sealing surfaces with emery cloth. Replace damaged parts.

REASSEMBLY

Clean all parts especially seating and sealing surfaces before reassembling valve. Worn parts should be replaced during re-assembly.

Install the leverage bracket (11) and apply Loctite® PST thread sealant to orifice (9) and thread into cover. Torque to maximum 22 ft-lbs.

Attach the air release float (13) to float arm (12) using screw (18) and lockwasher (17). Tighten securely. Lubricate and install small end of the orifice button (10) into the small end all the way into the hole in the float arm (12) so that the small end points toward the float ball. Position the float arm with float attached against the leverage bracket and install spring pin (14). Ensure free movement and the orifice button (10) contacts the orifice (9) as the float rotates toward the cover.

Install large orifice seat (3) so its neck extends into the outlet. Install support ring (4) and seat screws (6). Tighten seat screws in an alternating pattern but ensure the rubber seat is distorted.

Install the guide bearing (23) and place the cushion (21) on top of the guide bearing so its hole lines up with that of the guide bearing. Thread the float guide (22) into one of the threaded holes in the air/vacuum float and carefully tighten.

Carefully lower the air/vacuum side of the body so that the float guide is inserted into the guide bearing without dislodging the cushion.

Place the cover gasket (7) on the top of the body (1), position the cover (2) with the air release mechanism and air/vacuum seat attached and install the cover bolts.

Tighten the cover bolts in an alternating pattern.

Carefully introduce pressure and check for leaks

Allow valve to remain under pressure for 24 hours then check again for leaks and tighten cover bolts if necessary.

REPLACEMENT PARTS

Genuine replacement parts are available from your local GA Industries representative or from the factory:

VAG USA, LLC
 234 Clay Avenue
 Mars, PA 16046 USA
 Telephone: 724-776-1020
 Fax: 724-776-1254
 E-mail: quotes-ga@vag-group.com

Please have the nameplate data available when ordering parts.

PARTS LIST
 (Refer to Figure 1)

Item	Name	Material
1.	Body	Cast or Ductile Iron
2.	Cover	Cast or Ductile Iron
3.	Air/Vacuum Seat	Buna-N Rubber
4.	Support Ring	316 Stainless Steel
5.	Air Release Float	316 Stainless Steel
6.	Seat Screws	Stainless Steel
7.	Cover Gasket	Composition
8.	Cover Bolts	A307 Steel
9.	Orifice	316 Stainless Steel
10.	Orifice Button	316 Stainless Steel
11.	Lev'rage Bracket	316 Stainless Steel
12.	Float Arm	316 Stainless Steel
13.	Air/Vacuum Float	316 Stainless Steel
14.	Spring Pin	Stainless Steel
15.	Pipe Plug	Steel
16.	Spring Pin	Stainless Steel
17.	Lock Washer	Stainless Steel
18.	Float Screw	Stainless Steel
19.	Pipe Plug	Steel
20.	Bushing	Steel (Note 1)
21.	Cushion	EPDM Rubber
22.	Ball Guide	UHMW Polyethylene
21.	Guide Bearing	Low Friction Polymer

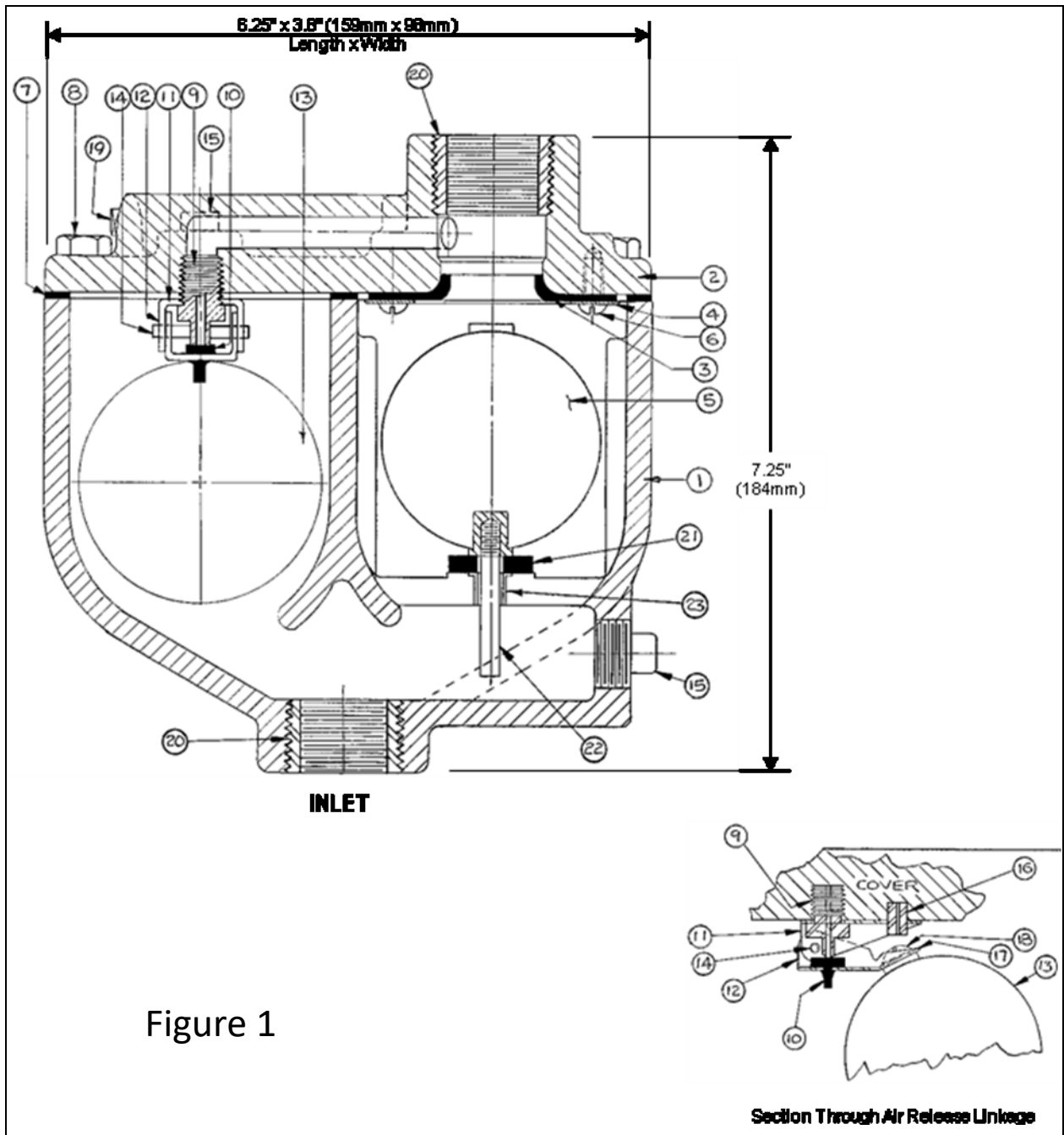

Figure 1

WARRANTY

For a period of one year from the date of shipment, and provided payments for the Products have been made by Buyer to Seller, Seller warrants to Buyer that its Products: (i) substantially conform to Seller's published specifications and (ii) are free from defects in material or workmanship. Specific products may have a warranty period greater than one year. Any Services provided by Seller are warranted to be performed in a good and workmanlike manner. Should a warranted Product or any Services fail to conform to these warranties, Buyer must promptly notify Seller in writing. Seller will, at its discretion and at no charge to the Buyer: (i) repair the Product or Services; (ii) replace the Product or any Services; or (iii) offer a full refund of that portion of the purchase price allocable to the non-conforming Product or Services. Warranty repair or replacement by Seller shall not extend or renew the applicable warranty period. Buyer shall obtain Seller's agreement on the specifications of any tests it plans to conduct to determine whether a non-conformance exists. Buyer shall bear the costs of access for Seller's remedial warranty efforts (including removal and replacement of systems, structures or other parts of Buyer's facility), de-installation, decontamination and re-installation. THE FOREGOING WARRANTIES ARE IN LIEU OF ALL OTHER WARRANTIES, EXPRESS OR IMPLIED, INCLUDING BUT NOT LIMITED TO THE IMPLIED WARRANTIES OF MERCHANTABILITY AND FITNESS FOR A PARTICULAR PURPOSE. This warranty allocates the risks of Product failure between Seller and Buyer. This allocation is recognized by both parties and is reflected in the price of the goods. Buyer acknowledges that it has read VAG USA, LLC's Terms and Conditions of Sale, understands it, and agrees to and is bound by its terms.

WHAT IS NOT COVERED BY WARRANTY

No representative of Seller has authority to waive, alter, vary or add to the terms hereof without prior written approval of an officer of Seller. Seller's warranty does not apply to: (i) dynamic vibrations imposed by the drive system in which such Products are installed unless the nature of such vibrations has been defined and accepted in writing by Company as a condition of operation; (ii) improper or unauthorized repair, installation or maintenance of the Products by a party other than Seller; (iii) use for purposes other than those for which designed, or other abuse, negligence, misuse, or normal wear and tear; (iv) unauthorized attachments, modifications or disassembly; (v) damage during shipping; or (vi) Products purchased from unauthorized distributors, resellers or internet sites. Buyer's care in selection, adequate testing at time of installation and proper installation, operation and maintenance of all Products is required for adequate performance.

LIMITATIONS OF LIABILITY

NOTWITHSTANDING ANY PROVISION OF THIS CONTRACT OR THE LAW, IT IS EXPRESSLY AGREED THAT SELLER'S TOTAL LIABILITY FOR ANY DAMAGES, COSTS OR EXPENSES ARISING OUT OF OR RELATED TO THIS CONTRACT OR ITS PRODUCTS OR SERVICES, WHETHER BASED IN CONTRACT, WARRANTY, INDEMNITY, TORT/EXTRA-CONTRACTUAL LIABILITY (INCLUDING NEGLIGENCE), STRICT LIABILITY OR OTHERWISE IS LIMITED TO THE REPAIR OR REPLACEMENT OF THE PRODUCT OR SERVICES OR, AT SELLER'S OPTION, A RETURN OF AN AMOUNT THAT SHALL NOT EXCEED THE PURCHASE PRICE. UNDER NO CIRCUMSTANCES WILL SELLER, IT'S OFFICERS, DIRECTORS, EMPLOYEES OR ASSIGNS BE LIABLE FOR ANY OTHER REMEDY, LOSS, COST, DAMAGE OR EXPENSE WHETHER DIRECT OR INDIRECT. IN NO EVENT WHATSOEVER SHALL SELLER BE LIABLE FOR ANY CONSEQUENTIAL, LIQUIDATE, EXEMPLARY OR PUNITIVE DAMAGES, INCLUDING BUT NOT LIMITED TO, LOSS OF USE, INCOME, PROFIT, OR PRODUCTION; INCREASED COST OF OPERATION, SPOILAGE OR DAMAGE TO MATERIAL, OR CHANGE OUT COSTS. BUYER SHALL INDEMNIFY, DEFEND AND HOLD SELLER HARMLESS FROM ANY LOSS, COST, EXPENSE, DAMAGE, OR CAUSE OF ACTION TO OR BY A THIRD PARTY THAT EXCEEDS THESE LIMITATIONS OF LIABILITY.