

LIST OF PARTS					
1	BODY	11	SHAFT	35	END PLATE BOLTS
2	BODY SEAT	12	DISC ARM SET SCREW	36	END PLATE O-RING
2.1	SEAT O-RING	13	INNER BUSHING	32	COWL
2.2	SEAT PIN	14	OUTER BUSHING	32.1	COWL BOLTS
3	DISC	15	GLAND	32.2	SCREEN
	DISC CENTER PIN	16	GLAND STUDS	32.3	COWL NUTS
4	DISC ARM	17	GLAND PACKING	32.4	COWL WASHER
5	SEAT WASHER	18	SHAFT LOCK PIN	37	STUD SLEEVE
5.1	SEAT FOLLOWER	19	DISC ARM KEY		
5.2	SEAT SCREWS	30	COUNTERWEIGHT ARM		
6	DISC NUT	30.1	CWT. ARM SET SCREW		
6.1	DISC NUT WASHER	30.2	CWT. ARM KEY		
6.2	DUSC NUT PIN	31	COUNTERWEIGHT		
8	COVER GASKET	31.1	CWT. SET SCREW		
9	COVER	33	COVER PLUG		
10	COVER BOLTS	34	SHAFT END PLATE		

DIMENSIONS						
VALVE SIZE	A	B	C	D	E	F
3"	4.25	16.5	11.5	5	16	6
4"	5	17.5	11.75	6	17.5	6.5
6"	6	20.5	13.25	7.5	22.5	8.75
8"	7.13	22.5	15	8	23.5	9
10"	9	23.5	16.75	10	30	11.5
12"	10.5	35	18.5	11.75	36	14

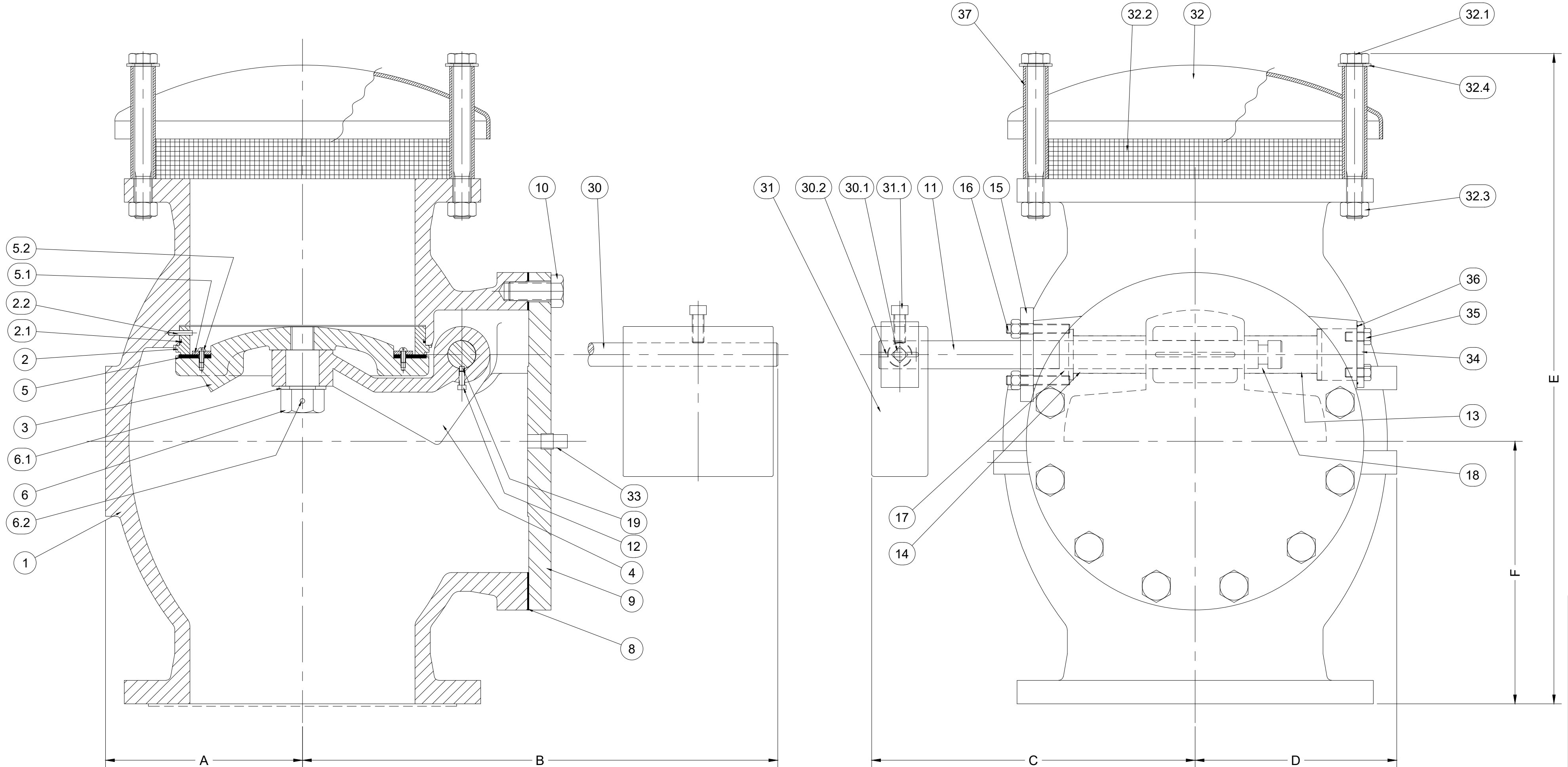

REV.	DESCRIPTION	DATE	BY
B	UPDATED SIZES	08-20-2019	JH
A	REDRAWN IN AUTOCAD; UPDATED AND ADDED DIMENSIONS, ADDED SIZES 18"-20"	08-15-2017	DAK

DIMENSIONS IN INCHES
 STANDARD TOLERANCES (UNLESS OTHERWISE NOTED)
 X = ±.1
 XX = ±.01
 XXX = ±.005
 FRACTIONS = ±1/64
 ANGLES = ±1°
 DRAFTS: 3° MAX
 PER ANSI Y14.5M GD&T -3/32 FLATNESS, ROUNDNESS, POSITION

CASTING STOCK MINIMUM (FOR MACHINED SURFACES)
 0 TO <1 = 1/8
 1 TO <6 = 3/16
 6 TO <12 = 1/4
 12 AND > = 3/8

GA INDUSTRIES
 FIGURE #991 HIGH CAPACITY SEWAGE VACUUM RELIEF & AIR INLET VALVE

SERIAL NO.	FIG. NUMBER	DATE	REFERENCES	FILE	DRAWING NO.	REV.	DRAWN BY	APPR. BY	SCALE	PROPERTY OF
	991	04-15-1992		EAV	EAV-7060	B	M.JD		NTS	VAG USA, LLC.

O:\Projects\Engineering\Autocad\Empire\Empire-SIEAV-7060-B.dwg