

VALVE DIMENSIONS																
SIZE	B		C		D		E		F		G		H		NO. OF TAPPED HOLES	WEIGHT IN LBS.
	IN.	MM	IN.	MM	IN.	MM	IN.	MM	IN.	MM	IN.	MM	IN.	MM		
3"	7.52	191	9.96	253	8.00	203	14.53	369	0.75	19	3.19	81	9.06	230	0	70
4"	9.02	229	10.98	279	9.00	229	16.90	429	0.95	24	4.25	108	9.45	240	2	112

NOTES:

1. FLANGE DRILLING PER ANSI B16.1 CLASS 125
2. ACTUATOR SUPPLIED IN POSITION A UNLESS SPECIFIED OTHERWISE
3. IN COMPLIANCE WITH AWWA C517
4. COLD WORKING PRESSURE: 175 PSI
5. HYDROSTATIC TEST PRESSURE: 265 PSI

PARTS LIST	
ITEM NO.	DESCRIPTION
1	BODY
2	PLUG
3	COVER
4	COVER BEARING
5	BODY BEARING
6	COVER O-RING
7	COVER BOLTS
8	GRIT EXCLUDER SEAL
9	THRUST BEARING
10	BUSHING
11	RETAINING RING
12	U-CUP SEAL
13	KEY
14	GEAR ACTUATOR
15	GEAR ACTUATOR BOLTS

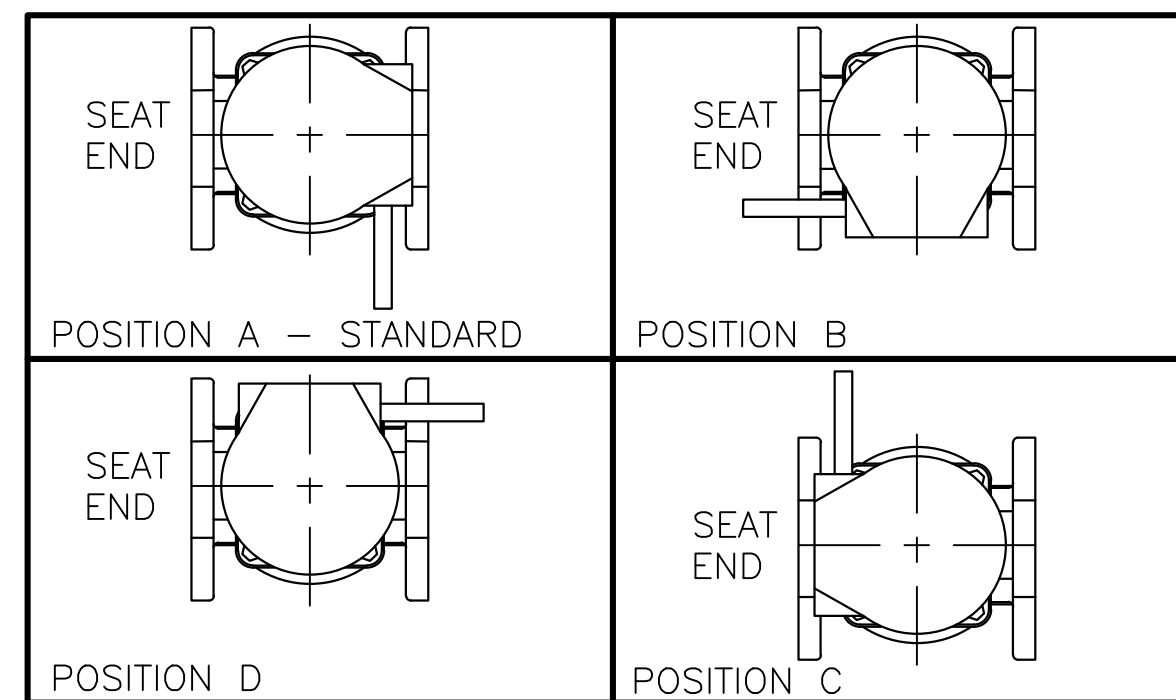
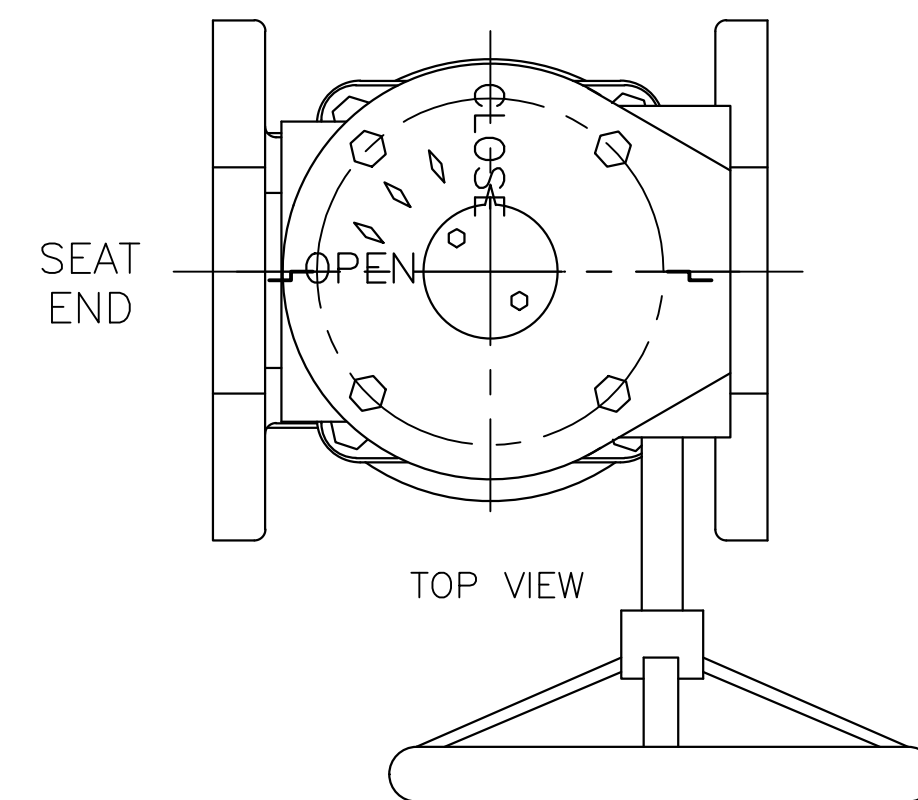
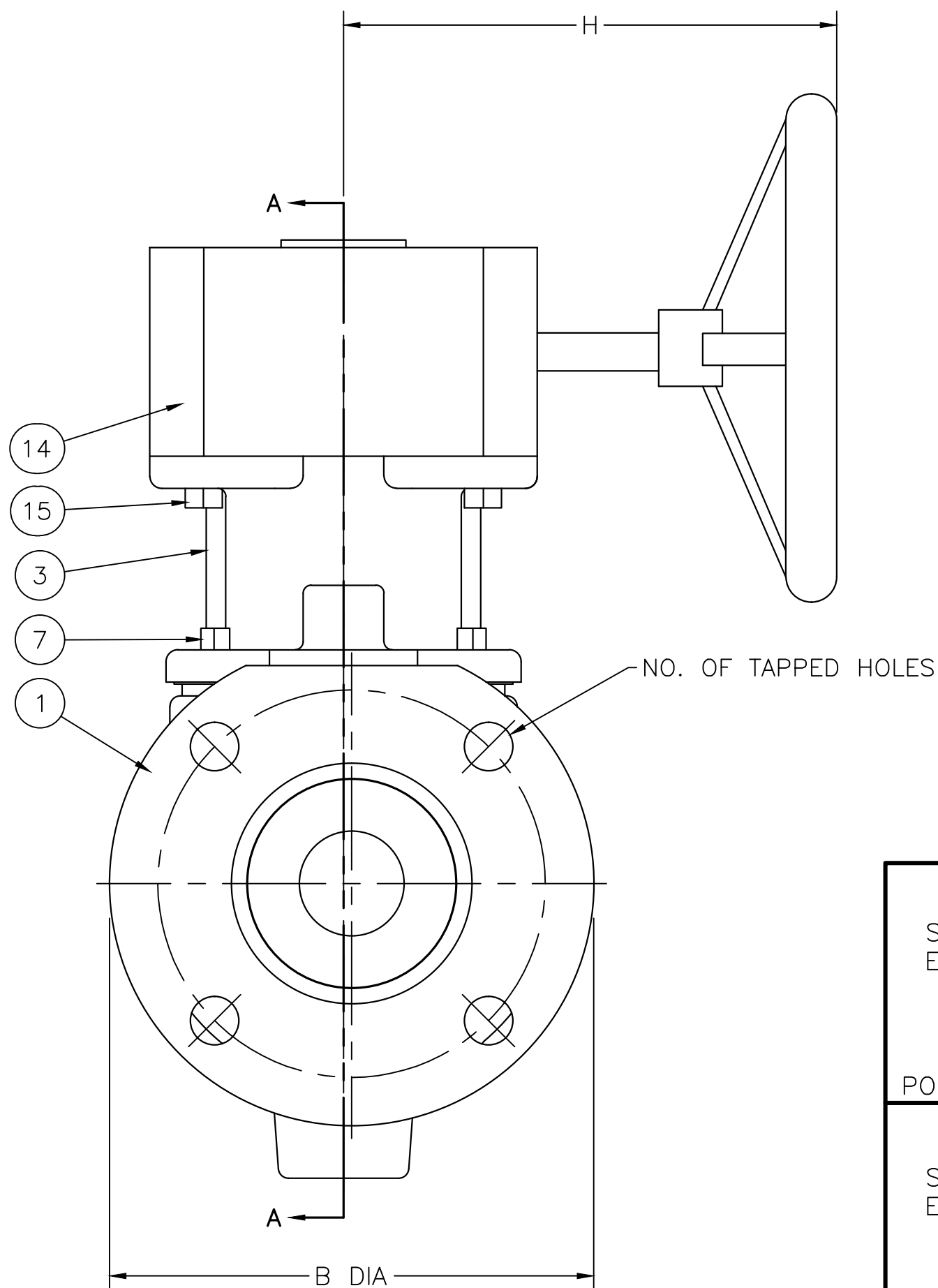
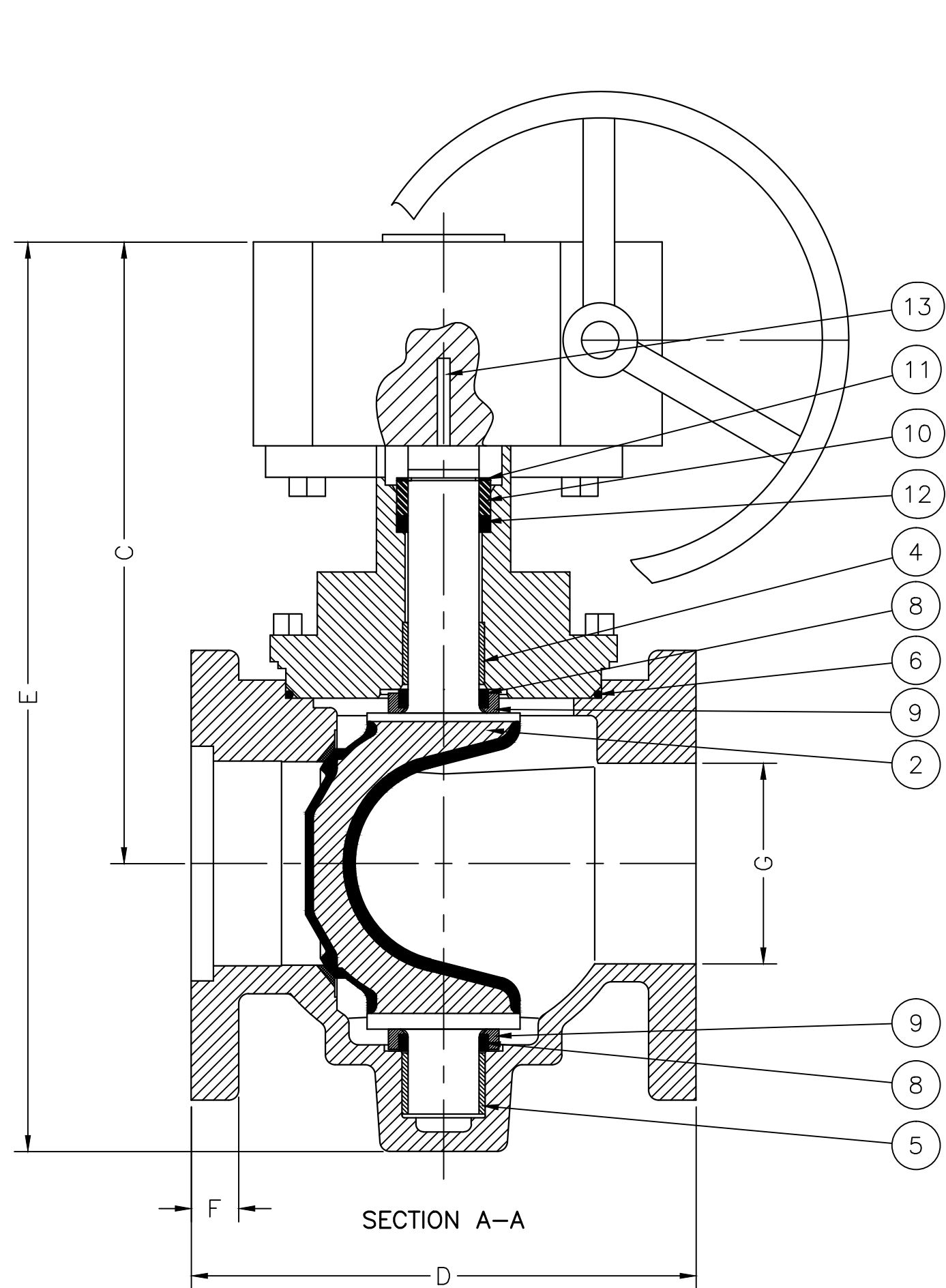

GA INDUSTRIES, LLC

3"-4" ECO-CENTRIC PLUG VALVE
WORM GEAR ACTUATOR W/HANDWHEEL
ANSI 125 LB FLANGES

STANDARD TOLERANCES (UNLESS OTHERWISE NOTED) FINISHED SURFACES ONLY DIMENSIONS SHOWN IN INCHES .x = ±.02 .xx = ±.01 .xxx = ±.002 FRACTIONS ±1/64" ANGLES ±1° FINISH ♀- XX RMS	SERIAL NO. *	SCALE N.T.S.	DRAWN BY HGM
	REFERENCES *	EFFECTIVE DATE 08-13-2009 TO	APPR. BY JT
	FIG. NUMBER 517	FILE PL	DRAWING NO. PL-1000
			REV.

REV.	DESCRIPTION	DATE	BY
* *			

J:\AUTOCAD\PLUG\PL-SHOW\PL-1000.DWG