

VALVE DIMENSIONS																
SIZE	B		C		D		E		F		G		H SQ.		NO. OF TAPPED HOLES	WEIGHT IN LBS.
	IN.	MM	IN.	MM	IN.	MM	IN.	MM	IN.	MM	IN.	MM	IN.	MM		
3"	7.68	195	11.89	302	11.50	292	16.46	418	0.94	24	3.19	81	2	50.8	0	62
4"	9.13	232	12.87	327	14.25	362	18.80	478	0.98	25	4.25	108	2	50.8	0	96
6"	11.10	282	14.25	362	15.75	400	21.02	534	1.06	27	6.26	159	2	50.8	0	138
8"	13.39	340	17.32	440	17.36	441	26.69	678	1.12	28	8.27	210	2	50.8	0	253

- NOTES:
 1. FLANGE DRILLING PER ANSI A21.1 AWWA C111
 2. IN COMPLIANCE WITH AWWA C517
 3. COLD WORKING PRESSURE: 175 PSI
 4. HYDROSTATIC TEST PRESSURE: 265 PSI

PARTS LIST	
ITEM NO.	DESCRIPTION
1	BODY
2	PLUG
3	COVER
4	COVER BEARING
5	BODY BEARING
6	COVER O-RING
7	COVER BOLTS
8	GRIT EXCLUDER SEAL
9	THRUST BEARING
10	BUSHING
11	RETAINING RING
12	U-CUP SEAL
13	KEY
14	SQUARE NUT
15	SQUARE NUT BOLTS
16	ADJUSTABLE TORQUE COLLAR

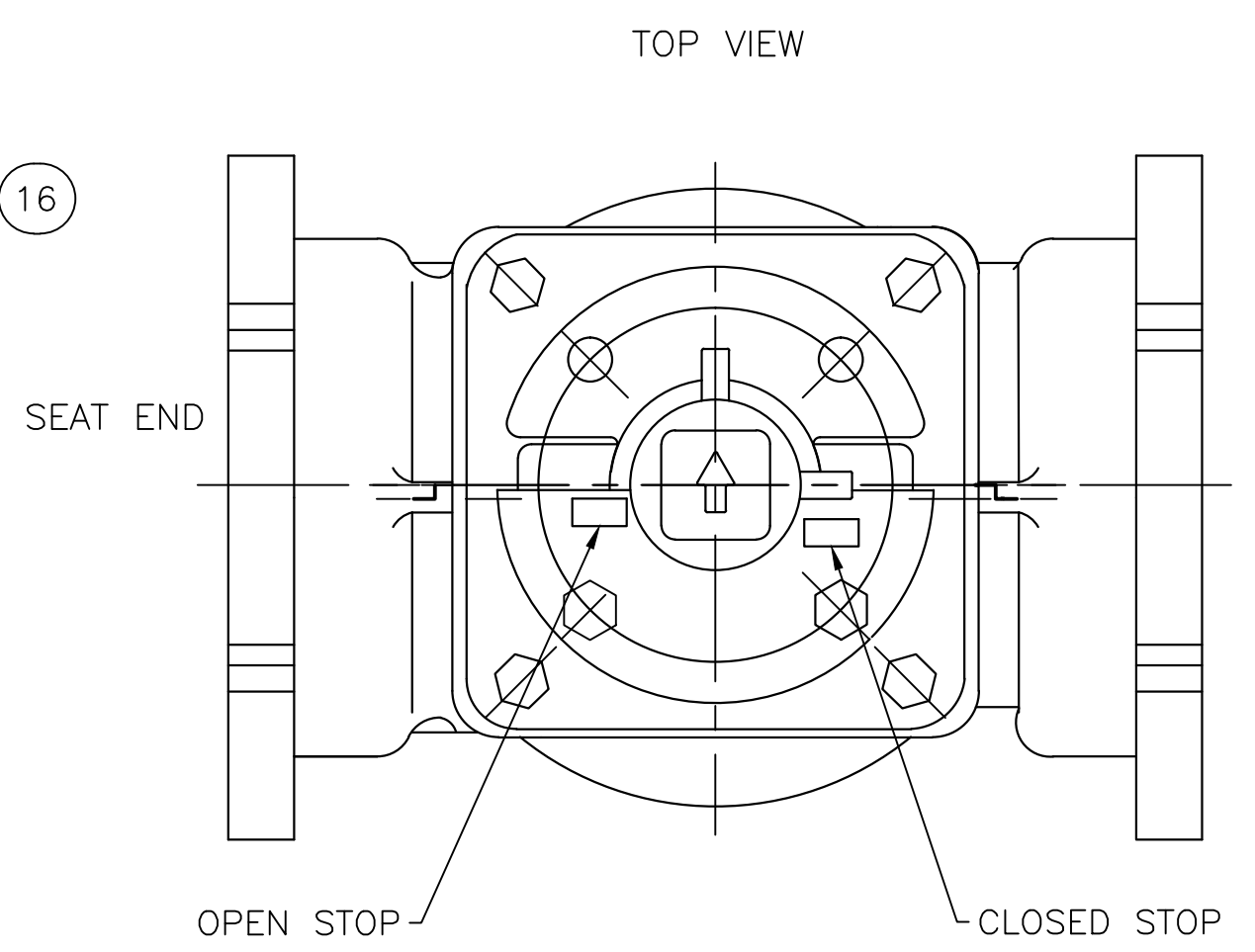
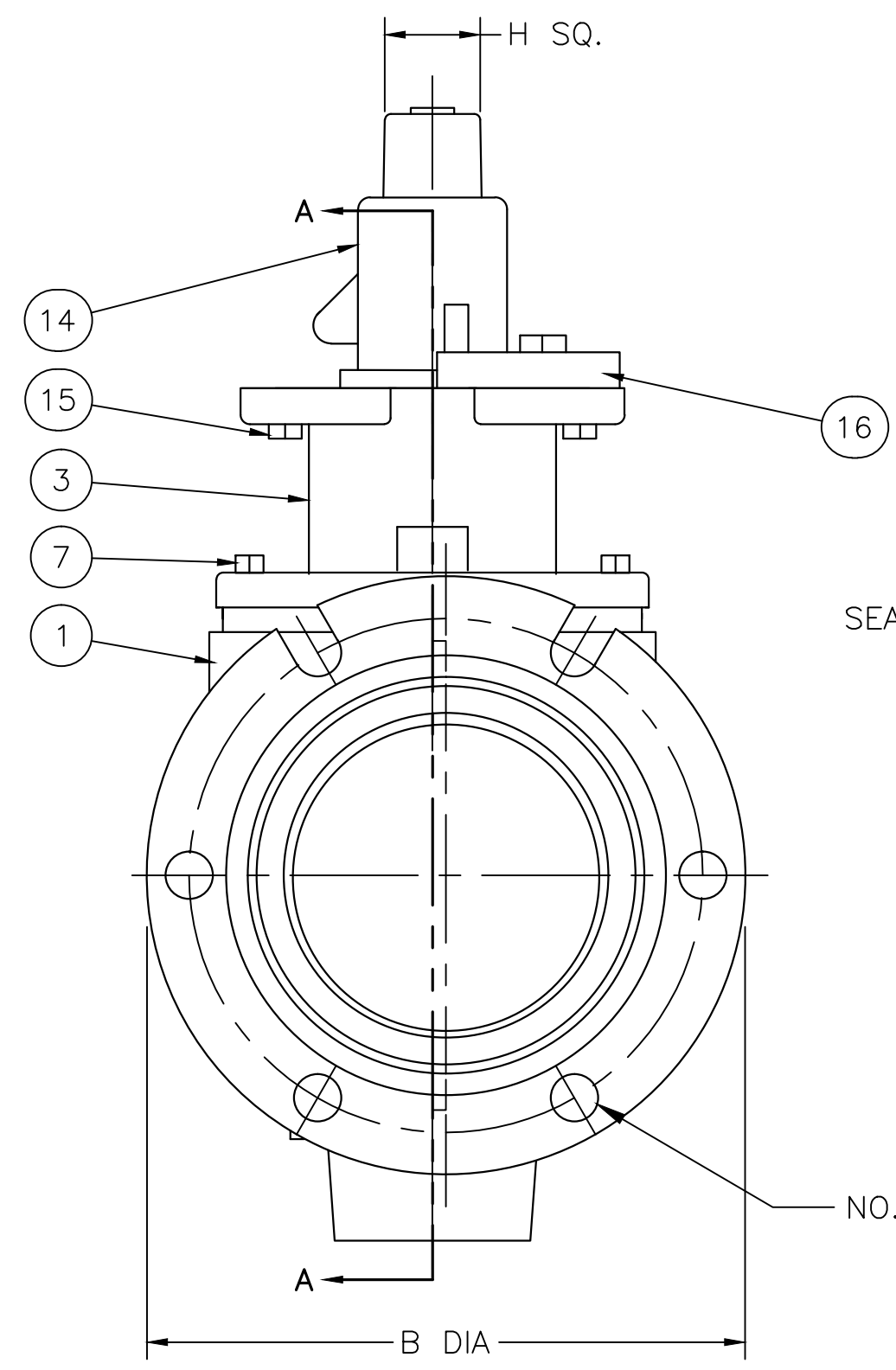
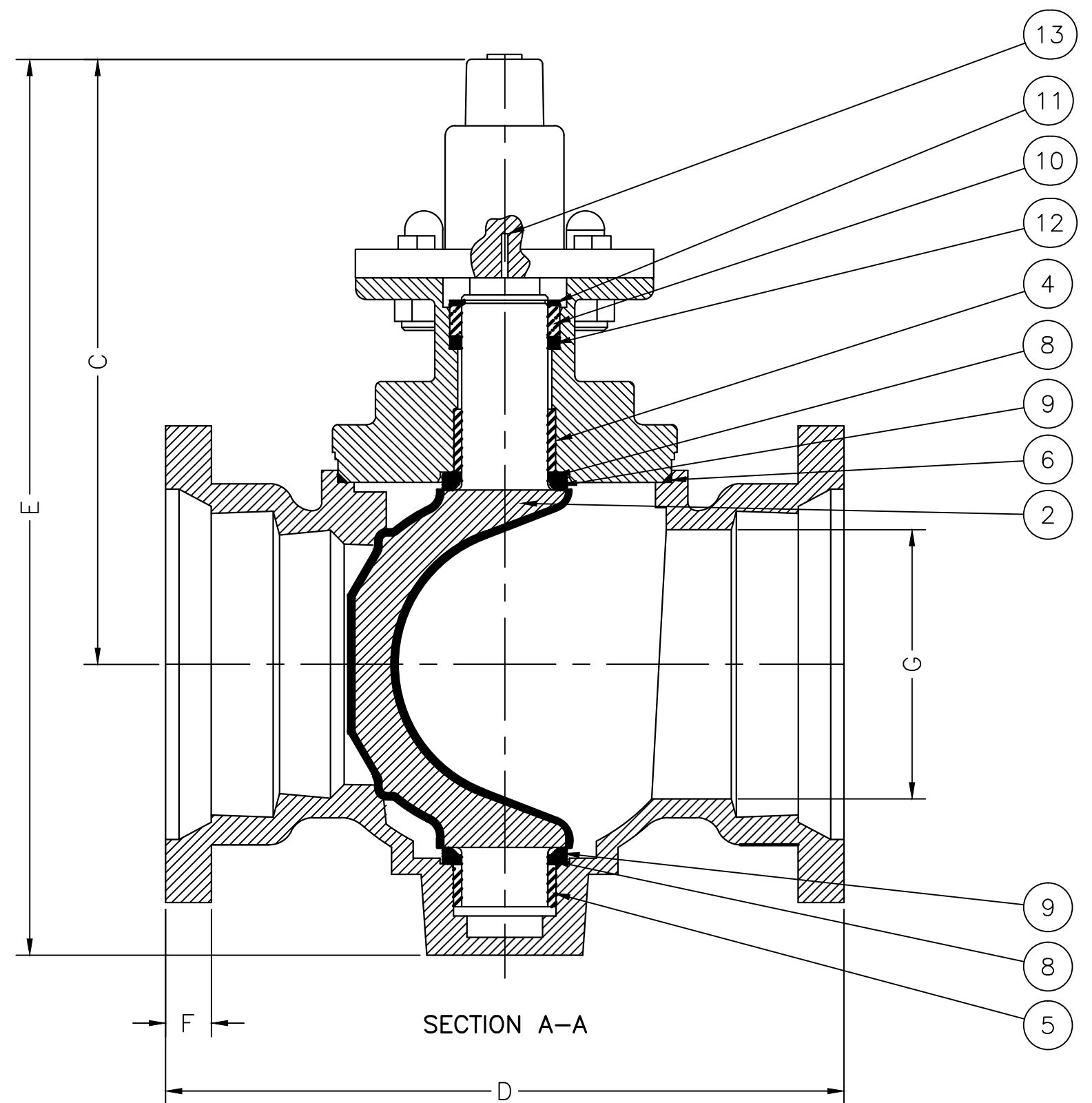

GA INDUSTRIES, LLC
 3"-8" ECO-CENTRIC PLUG VALVE
 W/DIRECT OPERATING NUT
 MECHANICAL JOINT FLANGE

STANDARD TOLERANCES (UNLESS OTHERWISE NOTED) FINISHED SURFACES ONLY DIMENSIONS SHOWN IN INCHES .x = ±.02 .xx = ±.01 .xxx = ±.002 FRACTIONS ±1/64" ANGLES ±1° FINISH $\sqrt{\text{XX}}$ RMS	SERIAL NO. *	SCALE N.T.S.	DRAWN BY HGM APPR. BY JT	
	REFERENCES *	EFFECTIVE DATE 07-17-2009 TO	FIG. NUMBER 517	DRAWING NO. PL-1002

REV.	DESCRIPTION	DATE	BY
* *			

J:\AUTOCAD\PLUG\PL-SHOW\PL-1002.DWG