

INSTALLATION, OPERATION AND MAINTENANCE MANUAL

FIGURE SB200

SLAMINATOR® RUBBER FLAPPER CHECK VALVE

TABLE OF CONTENTS

Introduction	2
Receiving & Storage	2
Description of Operation	2
Valve Construction	2
Installation	3
Preventive Maintenance	3
Trouble Shooting	3
Disassembly	3
Reassembly	4
Visual Position Indicator	4
Limit Switch Installation/Adjustment	4
Backflow Actuator Installation	5
Parts & Service	6
Repair Kits	6
Warranty	6



234 Clay Avenue • Mars, PA 16046 USA
Telephone (724) 776-1020 • Fax (724) 776-1254
E-mail: info-ga@vag-group.com



WARNING: Cancer and Reproductive Harm – www.Prop65Warnings.ca.gov

Figure SB200 Slaminator[®] Rubber Flapper Check Valve

INTRODUCTION

This manual will provide the information to properly install, operate and maintain the valve to ensure a long service life. The GA Industries Figure SB200 Slaminator[®] Rubber Flapper Check Valve is designed to provide years of dependable operation. This manual will provide you with the information needed to properly install and maintain the valve and to ensure a long service life.

The valve is of the swing check type utilizing an angled seat and fully encapsulated, resilient disc. It opens to allow fluid flow in the forward direction and closes automatically to prevent flow in the reverse direction.

The Figure SB200 can handle a wide range of fluids including those containing suspended solids. The valve's size, flow direction, maximum working pressure, and series number are cast on the valve body or stamped on the nameplate.

CAUTION

Do not use valve for line testing at pressures higher than nameplate rating or damage to valve may occur.

The "Maximum Working Pressure" is the non-shock pressure rating of the valve at 150° F. The valve is not intended as an isolation valve for line testing at pressures higher than the valve rating.

RECEIVING AND STORAGE

Inspect valves upon receipt for damage in shipment. Unload all valves carefully to the ground without dropping. Do not allow lifting slings or chains to contact the backflow actuator or visual position indicator (if provided). Use eye bolts or rods through flange bolt holes to lift large valves.

Valves should remain crated, clean and dry until installed to avoid weather related damage. For storage longer than six months, apply a thin coat of approved lubricant to the flexible disc.

Do not remove flange protectors until ready to install or expose flexible disc to sunlight or ozone for an extended period.

DESCRIPTION OF OPERATION

The valve is designed to automatically prevent reverse flow. During forward flow conditions, the movement of the fluid forces the disc to the open position allowing 100% unrestricted flow area through the valve. Upon flow reversal, the disc automatically returns to the closed position to prevent reverse flow.

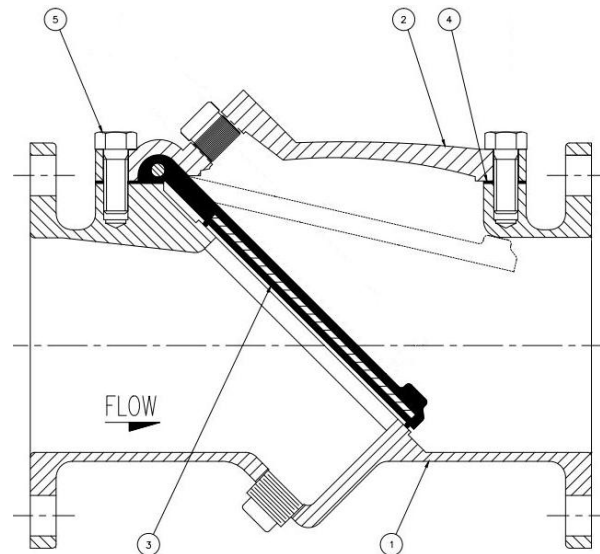

Figure 1

Item	Description	Standard Material
1	Body	Ductile Iron
2	Cover	Ductile Iron
3	Flexible Disc	Buna-N Rubber Encapsulated Steel
4	Gasket	Buna-N
5	Cover Bolt	Stainless Steel

VALVE CONSTRUCTION

The standard GA Industries Figure SB200 Slaminator[®] Rubber Flapper Check Valve is constructed of rugged ductile iron body with a reinforced rubber flexible disc and a stainless steel internal spring to assist closure. See the specific Materials List submitted for the order if other than standard construction. The disc and spring are the only moving parts assuring long life with minimal maintenance. The body (1) is

flanged for connection to the pipeline with an open top sealed with a cast cover (2). The flexible disc (3) and spring (6) are retained by the cover.

An optional valve mounted position indicator, with or without limit switch, is available to provide local and remote position indication. These also can be field installed (see Page 4).

An optional backflow actuator is available to manually open the valve to allow reverse flow. The backflow device can be easily installed in the field (see Page 5).

INSTALLATION

The Figure SB200 Slaminator® Rubber Flapper Check Valve must be properly installed for proper operation. It may be installed in either horizontal or vertical (flow-up) applications. However, when horizontal, the valve must be installed with the nameplate facing up. In all installations, the arrow cast in the valve cover must be pointed in the direction of forward flow.

Do not remove flange protectors until ready to install and ensure there is no debris inside the valve before installation.

Flanged valves should only be mated with flat-faced pipe flanges equipped with full-face gaskets.

CAUTION

The use of ring gaskets or mating flanges with a raised face may damage valve flanges.

The valve and adjacent piping must be supported and aligned to prevent imposing stress on the valve. Once the flange bolts or studs are lubricated and inserted around the flange, uniformly hand tighten. Then tighten the bolts to the recommended torque in graduated steps using the cross-over tightening method. If leakage occurs, allow gaskets to absorb fluid and check torque and leakage after 24 hours. Do not exceed bolt rating or extrude gasket.

PREVENTIVE MAINTENANCE

The Figure SB200 Slaminator® Rubber Flapper Check Valve requires no scheduled lubrication or maintenance. The valve can be inspected or serviced without removal from the line.

Valve Inspection: If internal inspection of the valve is required, follow the disassembly instructions provided below.

TROUBLESHOOTING

Common problems and solutions are presented below to assist you in troubleshooting the valve assembly in an efficient manner.

- Leakage at flanges

Tighten bolts, replace gasket.

- Valve leaks backwards when closed

Inspect disc for damage and replace. Inspect metal seating surface; clean if necessary.

- Valve does not open

Check for obstruction in valve; see Disassembly procedure below. Operating pressure may be insufficient to open valve. If less than 0.5 PSIG review application with factory

- Leakage at Backflow Actuator

Remove line pressure and exercise actuator. If leak persists, replace seals in actuator; see the Backflow Actuator Seal Replacement Procedure on Page 6.

DISASSEMBLY

The valve can be disassembled for inspection or repair while in the line or when removed if more convenient. All work on the valve should be performed by a skilled mechanic with proper tools. A power hoist should be employed when disassembling large valves.

WARNING

Lock out any associated pumps. Isolate the valve and relieve pressure before removing it from the line or disassembling while in the line or pressure may be released causing bodily harm.

Relieve pressure and drain the pipeline. Refer to figure 2 on page 2. Remove the cover bolts (4), pry cover (2) loose and lift off valve body. Remove flexible disc (3) and inspect for cracks, tears or damage in rubber sealing surface. Inspect seating surface in body for damage. Check internal spring (6) and ensure it is securely attached to cover (2). Clean and inspect parts. Replace worn parts as necessary.

REASSEMBLY

Clean gasket surfaces on body and cover with a stiff wire brush in the direction of the serrations

or machine marks. Clean seating surface in body with emery cloth. Lay disc (3) over seat with beaded seating surface directed down toward machined seat. Install spring assist onto cover using (*) bolts. Lay cover gasket (5) and cover (2) with spring (6) over bolt holes and disc hinge. Insert lubricated bolts (4) noting that the bolts in the hinge area are longer than the other cover bolts. Incrementally and uniformly tighten cover bolts in a cross over pattern.

VISUAL POSITION INDICATOR OPERATION

The optional visual position indicator (Figure 2) provides a local indication of the flexible disc's position.

The counterweight (11) rests against the back of the flexible disc and pivots as the disc swings from closed to open. The word CLOSED is exposed when the valve is closed and OPEN when the valve is fully open.

VISUAL POSITION INDICATOR FIELD INSTALLATION

WARNING

Lock out any associated pumps. Isolate the valve and relieve pressure before removing it from the line or disassembling while in the line or pressure may be released causing bodily harm.

WARNING

Do not field install the visual position indicator unless the valve is in the horizontal position or damage to the indicator assembly may result. Once the indicator is installed, the valve may be installed in a vertical (flow up) pipe

- Remove pipe plug from the port in the cover
- Apply sealant to threads on the lower bushing (10)
- Insert counterweighted end of assembly (9) through the port and tighten, ensuring the indicator flag (23) and channel bracket (25) are parallel to the valve's centerline.
- Proper action can be verified by lifting the counterweight. Do not attempt to move the indicator flag by hand.
- Re-pressurize and check for leaks. If further tightening is needed, ensure

indicator remains parallel to valve centerline.

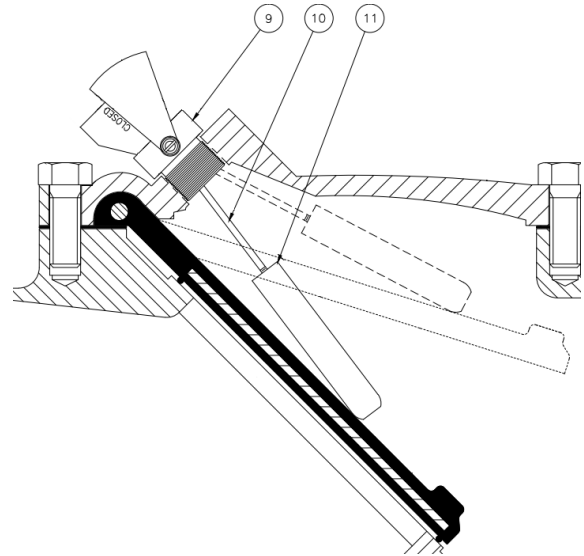

Figure 2

Item	Description	Material
9	Position Indicator Assembly	See Figure 3
10	Counterweight Arm	Stainless Steel
11	Counterweight	Stainless Steel

LIMIT SWITCH INSTALLATION AND ADJUSTMENT

An optional single pole double throw (SPDT) limit switch can be provided for remote indication of valve position. The limit switch can be supplied with the visual position indicator assembly or added later. Refer to Figure 3.

To install the limit switch on the visual position indicator assembly:

- Attach the limit switch mounting bracket (29) to the channel bracket (25) using the limit switch bracket mounting screws (30).
- Mount the limit switch (28) on the bracket using the limit switch mounting screws (31) so that the switch's "whisker" is on the left side of the flag (23) when looking at the flag.

Typically, the limit switch contacts close when the valve is closed. Adjust the switch position so that the indicator flag (23) actuates the switch when the valve is fully closed. **DO NOT ADJUST THE FLAG POSITION.**

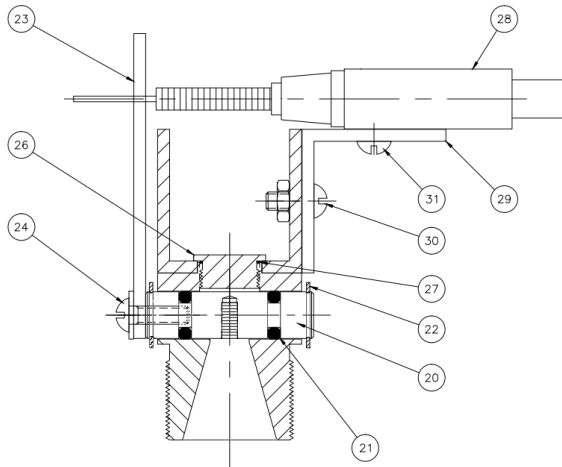

Figure 3

Item	Description	Material
19	Lower Bushing	Brass
20	Roller	Stainless Steel
21	Roller O-Ring	Buna-N Rubber
22	Retaining Ring	Stainless Steel
23	Indicator Flag	Stainless Steel
24	Indicator Flag Screw & Washer	Stainless Steel
25	Channel Bracket	Aluminum
26	Upper Bushing w/Flush Port	Stainless Steel
27	Upper Bushing O-Ring	Buna-N Rubber
28	SPDT Limit Switch	See Switch for Model Number
29	Switch Mounting Bracket	Aluminum
30	Bracket Mounting Screw & Nut	Stainless Steel
31	Switch Mounting Screw	Stainless Steel

BACKFLOW ACTUATOR OPERATION

The actuator is not designed to open the valve with pressure at its outlet. Therefore, prior to using the actuator, close the pump isolation valve and relieve line pressure between the check valve and isolation valve. To open the valve, loosen the jam nut (15) turn the T-handle clockwise. The handle should turn easily. When resistance is felt, the disc has reached its body stop and is in the fully open position. Then open the isolating valve to allow backflow through the valve.

WARNING

Relieve line pressure before using back flow actuator or damage may occur.

Upon completion of the backflushing operation, turn the T-handle fully counterclockwise to allow the valve disc to return to the closed position. Lock the backflow actuator in the closed position

with the jam nut (15). The system is again ready for normal operation.

BACKFLOW ACTUATOR FIELD INSTALLATION

- Isolate the rubber flapper check valve, depressurize and drain pipeline.

WARNING

Removal of the bottom plug while under pressure may cause bodily harm.

- Remove the pipe plug in the bottom boss of the valve.
- Inspect the backflow rod (16) and ensure the T-handle has been turned fully counterclockwise. The rod should extend about 1" past the end of the brass backflow tube (14). Apply thread sealant to brass threads.
- Insert the threaded end of the assembly into the valve boss. Slowly turn the assembly into the boss. Continue turning the assembly into the valve for a tight fit.
- Introduce pressure and check for leaks. Tighten if needed.

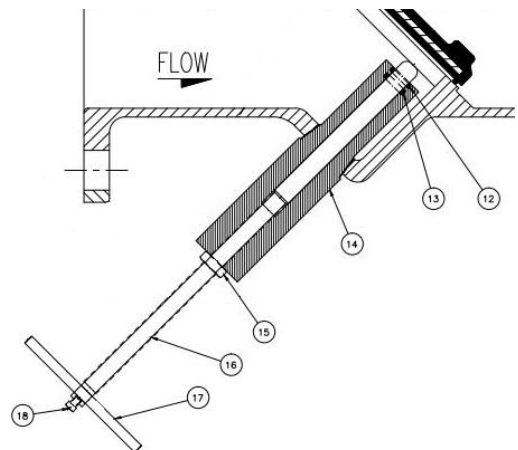

Figure 4

Item	Description	Material
12	Rod Wiper	Urethane
13	Rod Seal	Buna-N Rubber
14	Backflow Tube	Brass
15	Jam Nut	Stainless Steel
16	Backflow Rod	Stainless Steel
17	T-Handle	Stainless Steel
18	Setscrew	Stainless Steel

Backflow Actuator Seal Replacement:

There are two parts (12 & 13) on the backflow actuator that are subject to wear. Before replacing the seals, the pipeline must first be depressurized and drained. Next, remove the backflow assembly from the valve by turning the Backflow tube (14) counterclockwise. Disassemble the actuator as follows:

- Remove the Set Screw (18) with an Allen wrench.
- Loosen the jam nut (15) and spin it back until it's just under the T-Handle (17). Turn the T-Handle fully clockwise (17), then remove the Setscrew (18), T-handle (17) and jam nut (15) from the Backflow rod (16).
- Remove the rod (16) from the tube (14) by hand turning it counterclockwise. Do not use tools that would score or damage the smooth sealing surface.
- Using a pick remove the rod wiper (12) and rod seal (13) from the end of the backflow tube (14).
- Inspect and if needed clean the inside of the backflow tube.
- Lubricate rod wiper and rod seal with approved grease and install in the grooves in the backflow tube.
- If necessary, clean the backflow rod with fine emery cloth. Lubricate the non-threaded portion with approved grease and thread into the backflow tube being careful not to damage the rod seal or wiper.
- Install jam nut, T-handle and setscrew.
- Turn T-handle fully counterclockwise.
- Apply thread sealant to bushing and carefully thread into valve taking care not to cross-thread the bushing.
- Introduce pressure and check for leaks. Tighten if necessary.

PARTS AND SERVICE

Parts and service are available from your local representative or the factory. Make note of the Valve Size, Series No., and Serial No. located on the valve nameplate and contact:

VAG USA, LLC
234 Clay Avenue
Mars, PA 16046 USA
Telephone: 724-776-1020
Fax: 724-776-1254
E-mail: quotes-ga@vag-group.com

REPAIR KITS

Repair Kit includes Buna-N flexible disc (3) and cover gasket (4).

Size	Kit Number	Part Number
2"	RF2	2-80-16000-005
2½"	RF2.5	2-80-16000-062
3"	RF3	2-80-16000-008
4"	RF4	2-80-16000-009
6"	RF6	2-80-16000-010
8"	RF8	2-80-16000-011
10"	RF10	2-80-16000-000
12"	RF12	2-80-16000-001
14"	RF14	2-80-16000-002
16"	RF16	2-80-16000-003
18"	RF18	2-80-16000-004
20"	RF20	2-80-16000-006
24"	RF24	2-80-16000-007

WARRANTY

The Warranty for GA Industries valves is included in our Terms and Conditions which can be found here: <https://gaindustries.com/terms>

This page intentionally left blank