

NO.	DIMENSIONS																					
	2 1/2"		3"		4"		6"		8"		10"		12"		14"		16"		18"		20"	
	IN.	MM	IN.	MM	IN.	MM	IN.	MM	IN.	MM	IN.	MM	IN.	MM	IN.	MM	IN.	MM	IN.	MM	IN.	MM
A	12	305	12	305	13	330	17 1/2	445	18	457	23	584	28	711	33	838	36	914	40	1016	40	1016
B	7	178	7	178	8 1/2	216	9	229	12	305	14	356	16	406	22	559	23	584	24	610	24	610
C	5	127	5	127	5	127	6	152	9	229	9	229	11	279	13	330	14	356	17 1/4	438	17 1/4	438
D	10	254	10	254	11	279	12	305	14	356	15	381	17	432	20	508	24	610	28	711	28	711
E	5	127	5	127	5	127	7	178	8	203	9	229	11	279	14	356	16	406	18	457	18	457
F	5	127	5	127	4	102	3	77	3	77	---	---	8	204	---	---	---	---	---	---	---	---
G	15	381	15	381	16	406	19	483	21	533	23	584	32	813	34	864	35	889	37	940	37	940

NO.	PART NAMES	NO.	PART NAMES
1	BODY	19	DISC ARM KEY
2	BODY SEAT	20	CUSHION CHAMBER
2A	SEAT O-RING	21	CHAMBER SCREWS
2B	SEAT PIN	22	PLUNGER
3	DISC & CENTER PIN	23	PLUNGER O-RING
4	DISC ARM	25	CHAMBER LINER
5A	RENEWABLE SEAT	26	ADJUSTING SLEEVE
5B	SEAT FOLLOWER	27	SLEEVE LOCKNUT
5C	SEAT SCREWS	28	LINK
6	DISC NUT	28A	LINK PIN
6A	DISC NUT WASHER	29	LEVER
6B	DISC NUT PIN	29A	LEVER SET SCREW
8	COVER GASKET	29B	LEVER PIN
9	COVER	29C	LEVER COTTER PIN
10	COVER BOLTS	30	COUNTERWEIGHT ARM
11	SHAFT	30A	COUNTERWEIGHT ARM SET SCREWS
12	DISC ARM SET SCREW	30B	COUNTERWEIGHT ARM KEY
13	INNER BUSHING	31	COUNTERWEIGHT
14	OUTER BUSHING	31A	COUNTERWEIGHT SET SCREW
15	GLAND	32	CHECK VALVE
16	GLAND STUDS	33	COVER PLUG (14"-20" VALVES ONLY)
17	GLAND PACKING	34	SHAFT END PLATE
18	SHAFT LOCK PIN	35	SHAFT END PLATE BOLTS
		36	SHAFT END PLATE SEAL

HORIZONTAL INSTALLATION

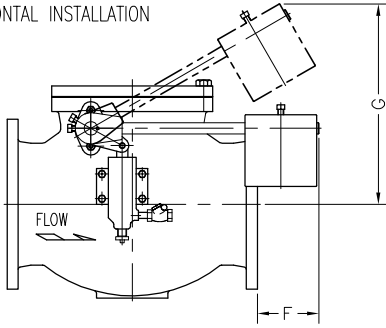

VERTICAL INSTALLATION

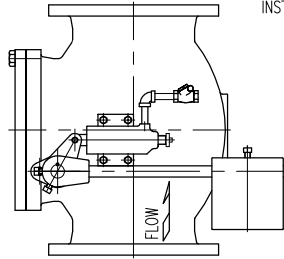

NOTE: SUFFIX "A" USED AFTER FIGURE NUMBER FOR VERTICAL INSTALLATION (FIG. NO. 250-DA)

NOTE: "A" DIMENSION ON VALVES WITH RAISED FACE FLANGES DOES NOT INCLUDE THE RAISED FACE HEIGHT

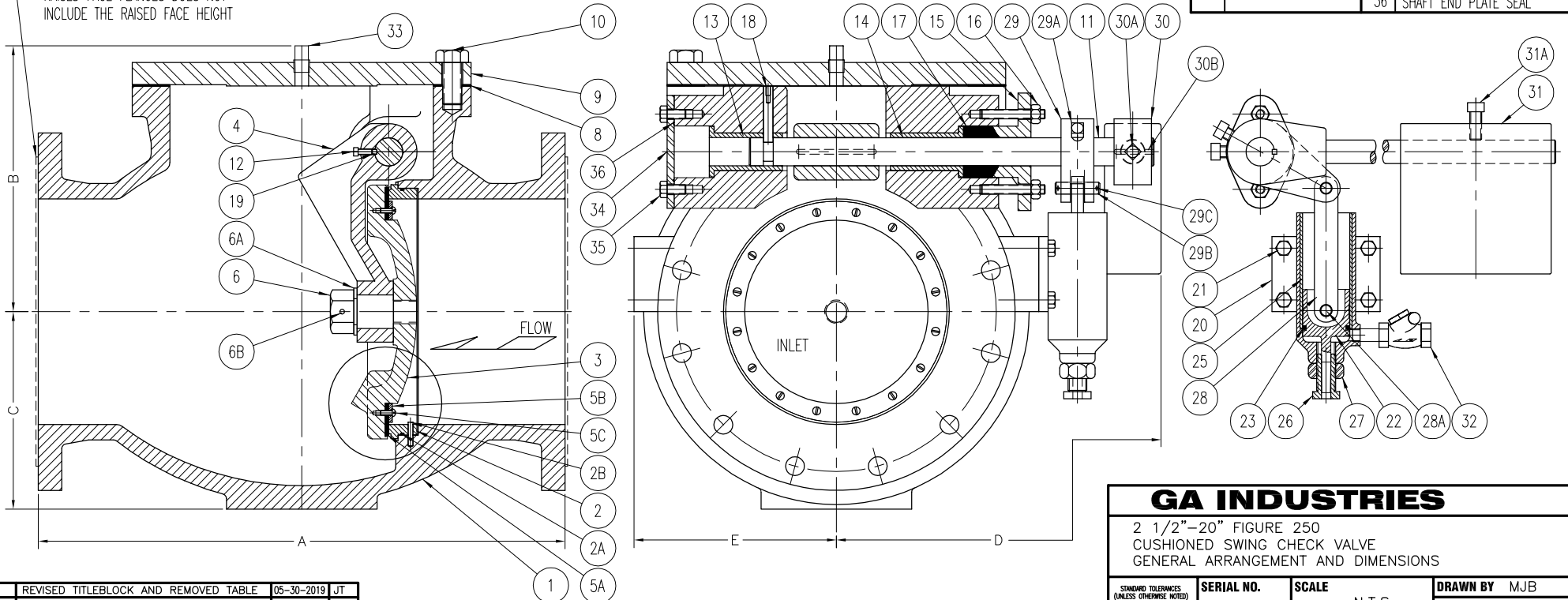

GA INDUSTRIES

2 1/2"-20" FIGURE 250
CUSHIONED SWING CHECK VALVE
GENERAL ARRANGEMENT AND DIMENSIONS

STANDARD TOLERANCES (UNLESS OTHERWISE NOTED) FINISHED SURFACES ONLY DIMENSIONS SHOWN IN INCHES x = ±.02 xx = ±.01 xxx = ±.002 FRACTIONS 1/16" ANGLES 1/2° FINISH .8F - XX RMS	SERIAL NO.	SCALE	DRAWN BY
		N.T.S.	MJB
REFERENCES	EFFECTIVE DATE	FILE	APPR. BY
	08-27-1993 TO	C	
	FIG. NUMBER	DRAWING NO.	REV.
SEE ABOVE	C	C-1018	J

REV.	DESCRIPTION	DATE	BY
J	REVISED TITLEBLOCK AND REMOVED TABLE	05-30-2019	JT
H	REMOVED MM VIEW	08-10-2018	JH
G	REDRAWN IN AUTOCAD	11-17-2006	RJT
F	REDRAWN FOR SIZE 3 (C)	10-18-1999	JJF
E	ADDED VALVE SIZES ITEM NO. 33	05-05-1998	MJB

J:\GA-VALVE (GA-SHOW\C-1018-.LDWG

AVAILABLE IN SIZE 1 & 11