

VALVE DIMENSIONS																		
SIZE	A		B		C		D		E DIA		F DIA		G		H SQ.		J	
	IN.	MM	IN.	MM	IN.	MM	IN.	MM	IN.	MM	IN.	MM	IN.	MM	IN.	MM	IN.	MM
42"	72	1829	32 3/4	832	44 1/4	1124	7 7/8	200	5 3/4	146	53	1346	6.4	162.5	1 1/2	38	2 5/8	67
48"	84	2134	36	914	47 13/16	1214	8 1/4	210	5 3/4	146	59 1/2	1511	6.4	162.5	1 1/2	38	3	76

PARTS LIST	
ITEM NO.	DESCRIPTION
1	BODY
2	PLUG
3	COVER BOLTS
4	COVER O-RING
5	COVER
6	THRUST BEARING
7	BEARING
8	PACKING
9	KEY
10	PLUG BUSHING
11	RETAINING RING
12	RETAINING BOLTS
13	PIPE PLUG
14	END PLATE O-RING
15	END PLATE
16	END PLATE SCREWS
17	COVER MOUNTING FLANGE
18	COVER MTG. FLG. SCREWS

- NOTES:
 1. FLANGE DRILLING PER ANSI B16.1 CLASS 125
 2. IN COMPLIANCE WITH AWWA C517
 3. COLD WORKING PRESSURE: 150 PSI
 4. HYDROSTATIC TEST PRESSURE: 225 PSI

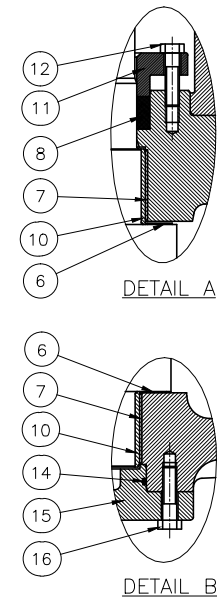
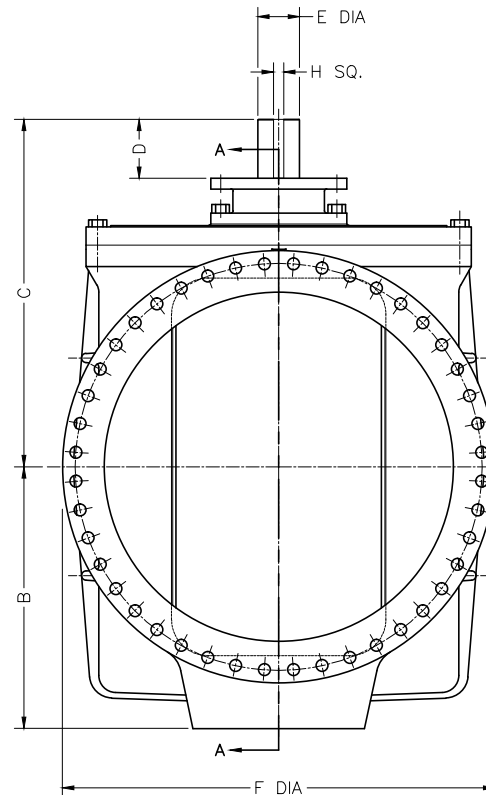
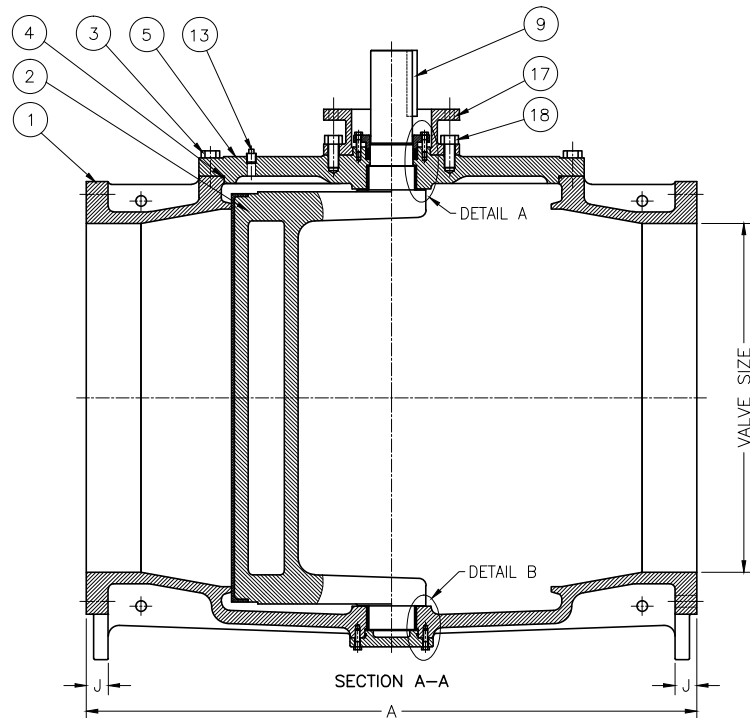
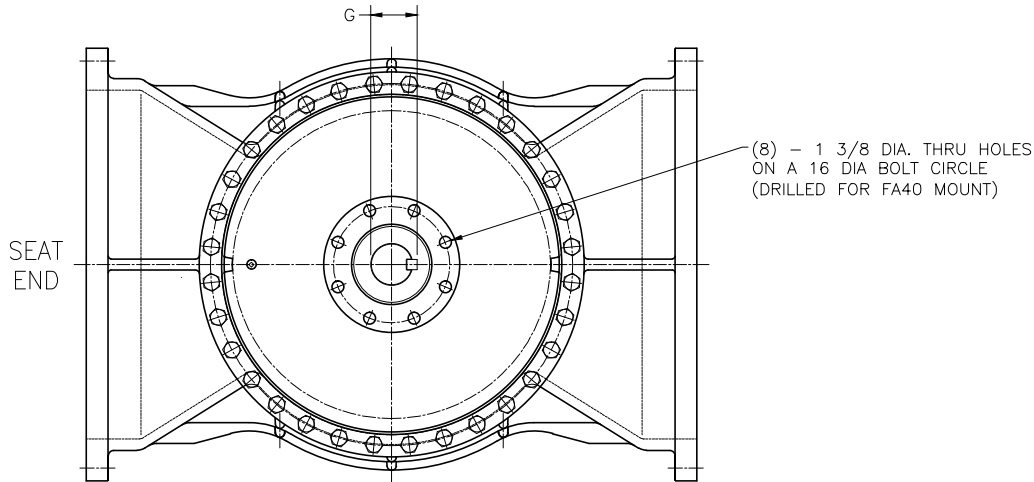

GA INDUSTRIES, LLC

42"-48" ECO-CENTRIC PLUG VALVE - FLANGED
 ANSI 125 LB FLANGES

STANDARD TOLERANCES (UNLESS OTHERWISE NOTED) FINISHED SURFACES ONLY DIMENSIONS SHOWN IN INCHES X .0005 XX .001 XXX .002 FRACTIONS: 1/16" ANGLES: 1° FINISH: 8° - XX RMS	SERIAL NO. *	SCALE N.T.S.	DRAWN BY SWR	
	REFERENCES *	EFFECTIVE DATE 11-09-2010	TO	APPR. BY JT
	FIG. NUMBER 517	FILE PL	DRAWING NO. PL-1042	REV. A

REV.	DESCRIPTION	DATE	BY
A	ITEM 11 & 12 WERE REVISED	02-11-2011	HGM

J:\AUTOCAD\PLUG\PL-SHOW\PL-1042-A.DWG
 AVAILABLE IN SIZES I AND II