

SEAT
END

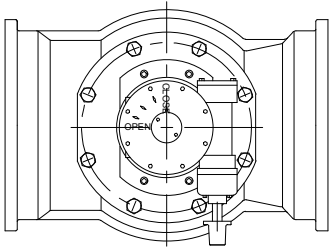

POSITION A - STANDARD

SEAT
END

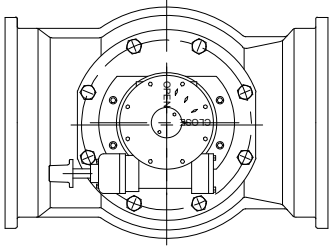

POSITION B

SEAT
END

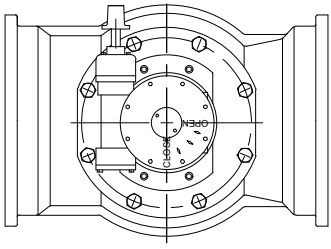

POSITION C

SEAT
END

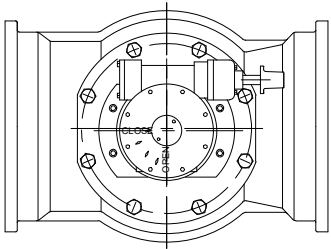

POSITION D

OPTIONAL ACTUATOR POSITIONS
CUSTOMER TO SPECIFY POSITION WITH ORDER
POSITION "A" SHOWN IN MAIN VIEW
POSITION "A" IS STANDARD

DIMENSIONS

Valve Size	A		B		C		ØD		ØE		F		H		J		L SQ.		APPROX. WEIGHT	
	IN	MM	IN	MM	IN	MM	IN	MM	IN	MM	IN	MM	IN	MM	IN	MM	IN	MM	LB	KG
14"	25.00	635	10.88	276	19.05	592	20.31	516	13.97	355	1.31	33.3	6.50	164	16.38	416	2.0	52	827	375.1
16"	29.02	737	13.00	330	20.85	638	22.56	573	16.13	410	1.38	35.1	6.50	164	16.38	416	2.0	52	1106	501.7
18"	37.99	965	13.88	334	20.85	638	24.83	631	18.00	457	1.44	36.6	6.50	164	16.38	416	2.0	52	1417	642.7
20"	44.00	1118	15.75	400	22.75	686	27.08	688	20.06	510	1.50	38.1	6.50	164	16.38	416	2.0	52	2095	950.3

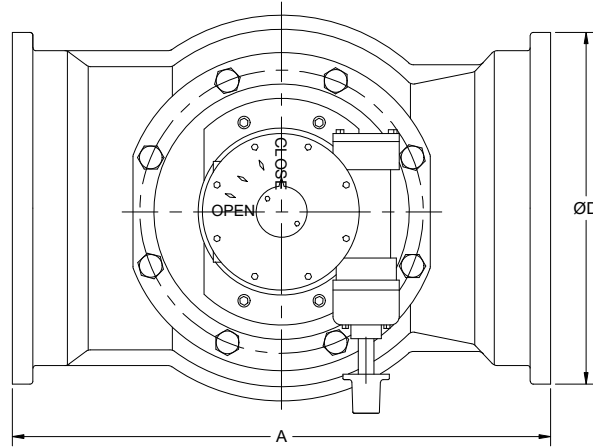

NOTES:

1. FLANGE DRILLING PER ANSI B16.1 / CL125
2. IN COMPLIANCE WITH AWWA C517
3. COLD WORKING PRESSURE: 150 PSI
4. HYDROSTATIC TEST PRESSURE: 225 PSI

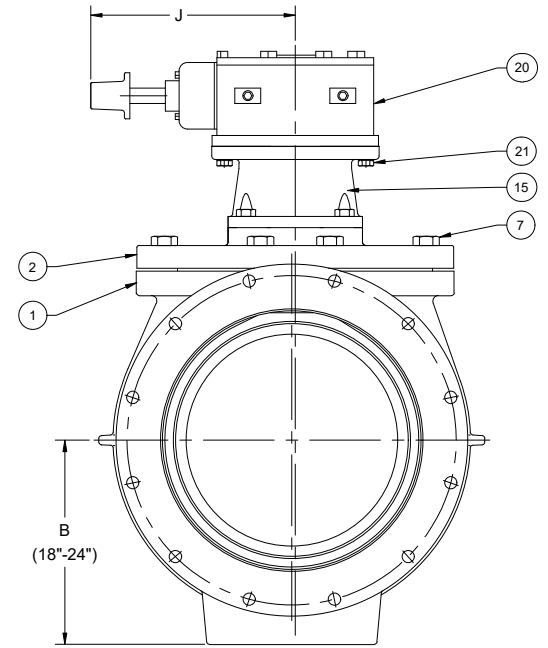
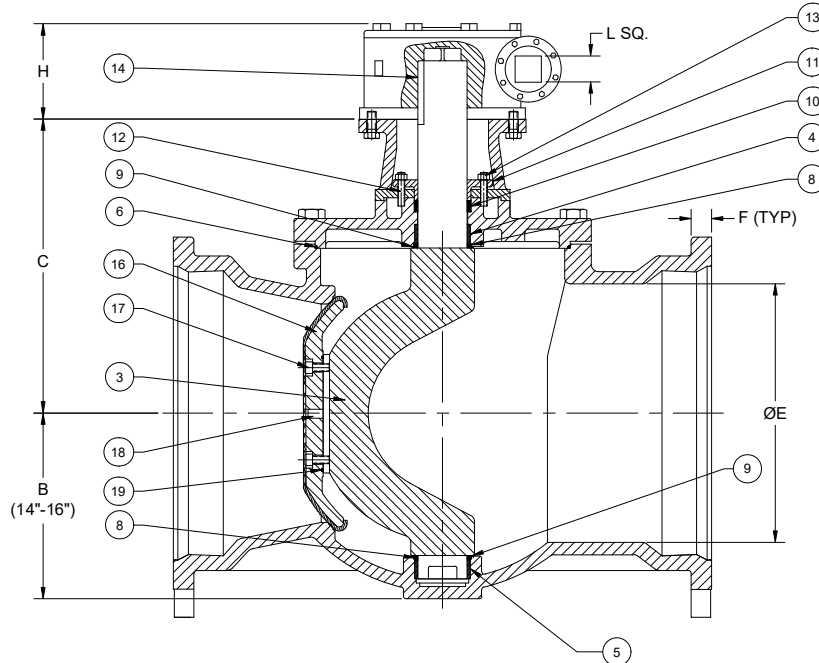

PARTS LIST	
NO.	Description
1	Body
2	Cover
3	Shaft
4	Cover Bearing
5	Body Bearing
6	Cover O-Ring
7	Cover Bolts
8	Grit Excluder Seal
9	Thrust Bearing
10	Packing
11	Gland
12	Gland Studs
13	Gland Nuts
14	Key
15	Mounting Bracket
16	Vulcanized Plug
17	Plug Screws
18	Plug Pin
19	Plug O-Ring
20	Worm Gear Actuator
21	Actuator Bolts

REV.	DESCRIPTION	DATE	BY

DIMENSIONS IN INCHES
STANDARD TOLERANCES (UNLESS OTHERWISE NOTED):
X = ±.1
XX = ±.05
XXX = ±.005
FRACTIONS = ±1/64
ANGLES = 30"
DRAFTS: 3" MAX
PER ANSI Y14.5M (2014) - (S) FLATNESS, ROUNDNESS, POSITION

GA INDUSTRIES, LLC
14" - 20" ECOCENTRIC PLUG VALVE w/ ADJUSTABLE PACKING
& BURIED SERVICE WORM GEAR ACTUATOR w/ SQUARE NUT
MECHANICAL JOINT FLANGES

SERIAL NO.	FIG. NUMBER	APPR. BY	DRAWN BY
	B517	JT	JT
DATE	SCALE	NTS	
10-24-2014			
REFERENCES	FILE	DRAWING NO.	REV.
PL-1005 / PL-2001	PL	PL-2012	

L:\Autocad\Plug\PL-Show\PL-2012.dwg