

DIMENSIONS

PARTS LIST

VALVE SIZE	A	B 125/150#	B 250/300#	C ©	D	E	F	G	H	K	L	M	P	R	S	APPROX. WEIGHT
6"	6	20	20	24 5/8	6 1/2	6 1/2	10	7 1/4	30	3 3/4	3 3/4	7	3 3/4	3	3/4-10 UNC	1,100
ⓑ 8"	8	23 1/2	23 1/2		8 1/4	7 3/4	12 1/2	7 3/4	30	5	4 1/2	9 3/4	5	4	3/4-10 UNC	1,300
ⓑ 10"	10	28 1/8	28 1/8		9 5/8	9	15	10	30	5	4 1/4	10 1/2	5	4 1/4	3/4-10 UNC	1,600
12"	12	31	32 1/2	32 1/2	10 7/8	10 3/4	15 1/2	9 1/2	30	7 1/2	5 1/4	13	7 1/2	5 1/4	3/4-10 UNC	2,200
ⓑ 14"	14	37	37		13	12 7/8	18 1/2	13	38	6 1/8	5 1/2	15	6 1/8	5 1/2	1"-8 UNC	3,000
ⓑ 16"	16	39	41		15	12 1/2	22	12 1/2	38	9 1/2	7	16 1/4	9 1/2	7	3/4-10 UNC	4,200
18"	18	43 1/4	43 1/4	46	16 1/2	15	23	15	38	9 1/2	7	20	9 1/2	7	3/4-10 UNC	4,500
Ⓐ 20"	20	47	49	47	18	16	26 1/2	16	38	10 1/2	7 1/2	21	10 1/2	7 1/2	1 1/4-7 UNC	5,500
24"	24	56	57 3/4	55	21 3/4	23	31 1/4	19 1/2	50	12 1/2	10	25	12 1/2	10	1 1/4-7 UNC	9,600
30"	30	70	70	61	27 1/4	24	40 1/2	24	50	12 1/2	10	30	12 1/2	10	1 1/4-7 UNC	16,000
36"	36	78	78	63	29	26 3/4	41 1/2	24 1/8	50	16 1/4	16 1/4	35	21 5/8	13	SEE "B-B"	24,000

No.	DESCRIPTION
54	HOUSING BOLTS
55	HOUSING DOWEL PIN
56	CYLINDER
57	ADAPTOR
58	ADAPTOR BOLTS
59	CYLINDER STUD
60	CYLINDER NUT
61	CYLINDER BOLT

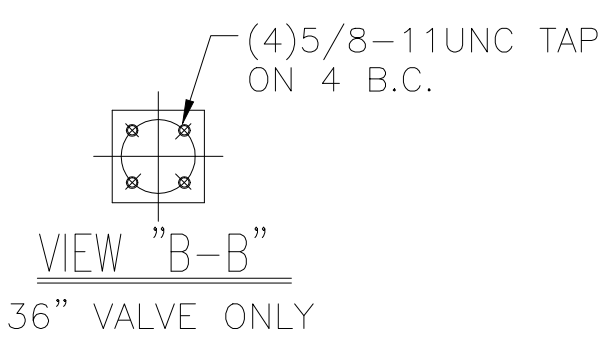
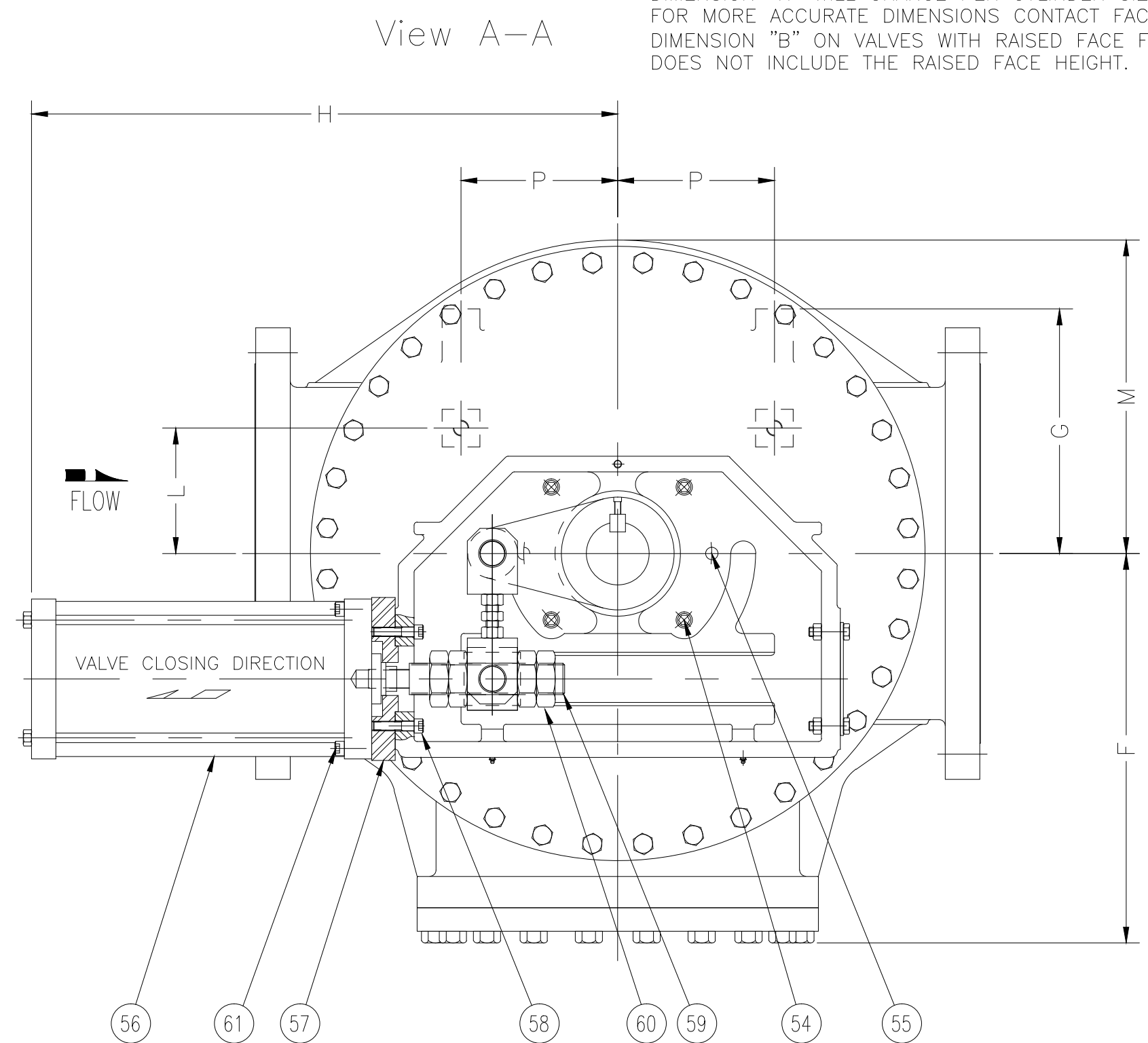
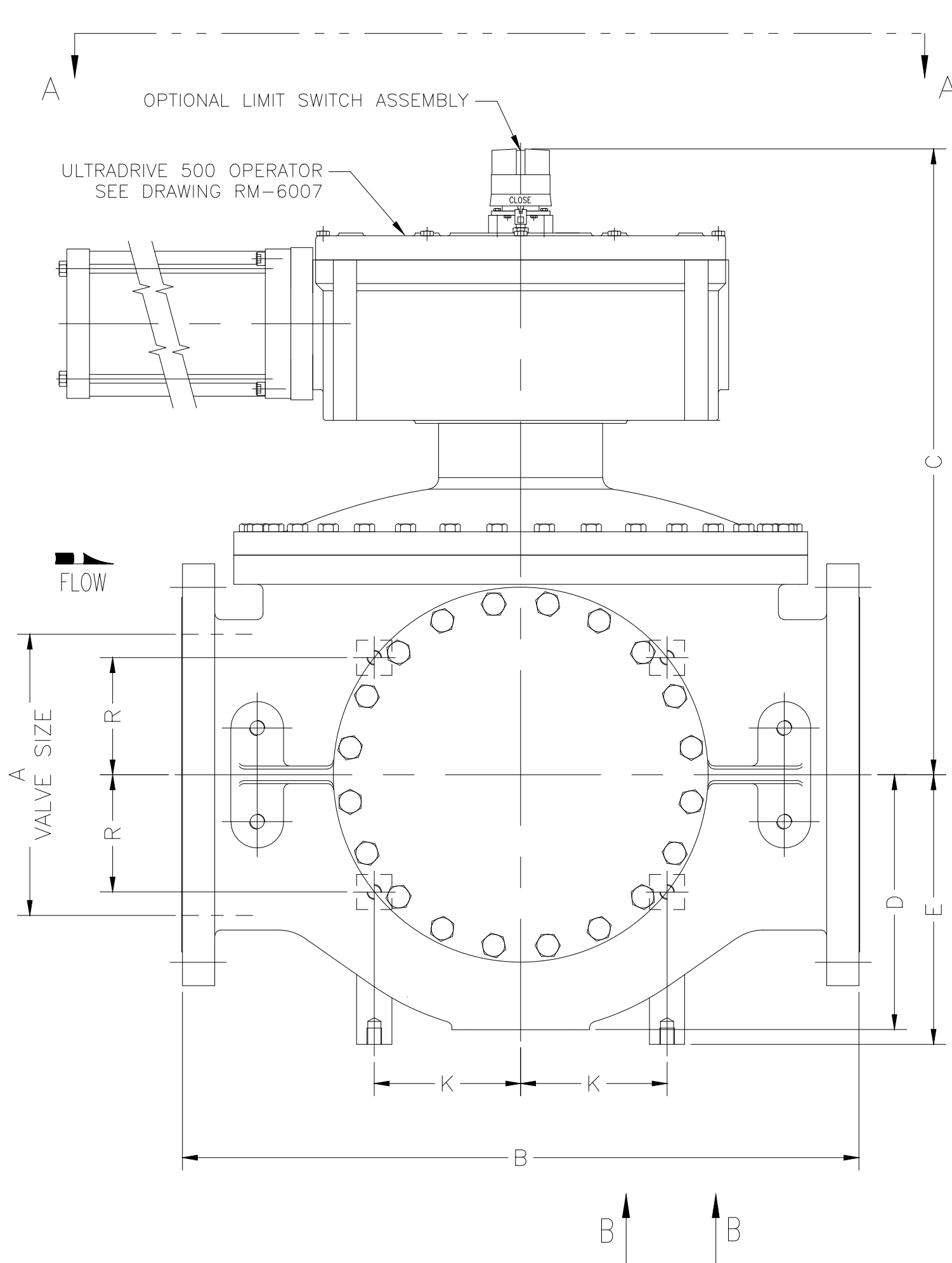
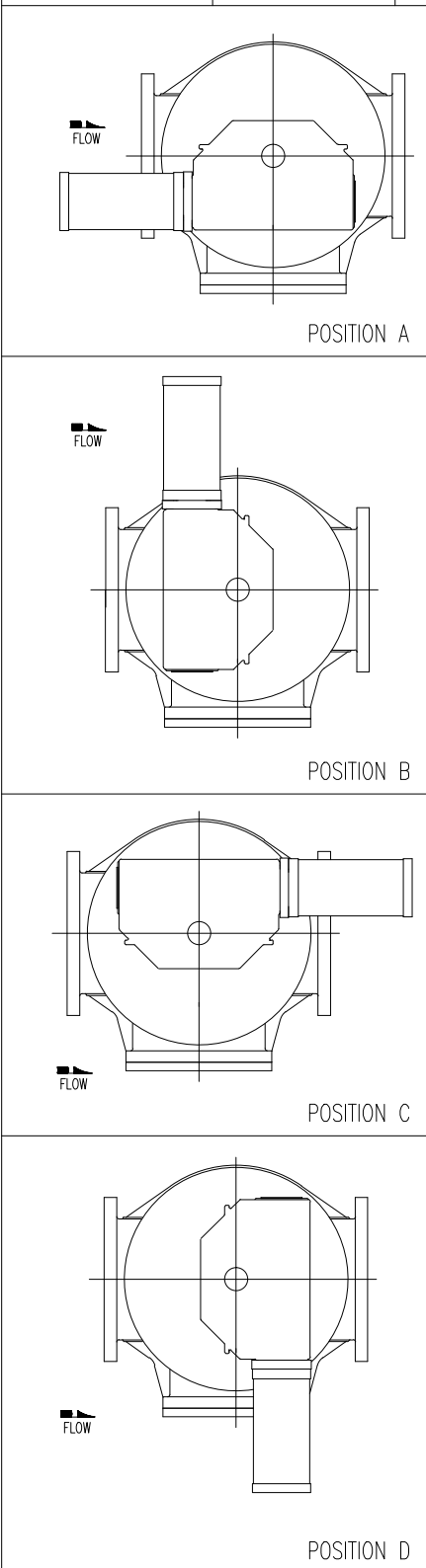

NOTES:
 DIMENSION "H" WILL CHANGE PER CYLINDER SIZE.
 FOR MORE ACCURATE DIMENSIONS CONTACT FACTORY.
 DIMENSION "B" ON VALVES WITH RAISED FACE FLANGES
 DOES NOT INCLUDE THE RAISED FACE HEIGHT.

REV.	DESCRIPTION	DATE	BY
D	ADDED WEIGHTS AND 150# & 300# TO DIMENSION CHART	04-07-2014	HGM
C	ADDED DIM. "C" ON 6" SIZE, DRAWN IN AUTOCAD	05-26-2009	RJT
B	ADDED 6" AND 16" SIZES	01-09-2004	JJF
A	ADDED 18" AND 20" SIZES	03-21-2003	JJF

GA INDUSTRIES, INC.

6"-36" ROTARY BALL VALVE, WITH CYLINDER OPERATED
 ULTRA DRIVE OPERATOR AND
 ACCESS COVER RIGHT SIDE FACING INLET (STANDARD)

STANDARD TOLERANCES (UNLESS OTHERWISE NOTED) FINISHED SURFACES ONLY DIMENSIONS SHOWN IN INCHES .x = ±.02 .xx = ±.01 .xxx = ±.002 FRACTIONS ±1/64" ANGLES ±1° FINISH ⌀/- XX RMS	SERIAL NO.	SCALE NONE	DRAWN BY JJF	
	REFERENCES	EFFECTIVE DATE 01-31-2003 TO	APPR. BY MJB	
	FIG. NUMBER	FILE R1	DRAWING NO. 81197	REV. D

J:\ROTARY\RT-SHOW\81197-D.DWG

AVAILABLE IN SIZES I AND III