

# Figures 200-D, 200-DBF, 200-DPI Rubber Flapper Check Valve

## Description

GA Industries Figure 200-D Rubber Flapper Check Valves have a full 100% flow area for low head loss and clog resistance. Long term reliability is ensured because the valve's reinforced rubber flexible disc is the only moving part and it's integral O-ring provides drop tight sealing at both low and high working pressures.

The valve's 45-degree seat angle, short stroke and its flexible disc's inherent memory combine to provide quick-closing, slam resistant operation.

The Figure 200-D can be easily fitted with backflow device and/or a visual position indicator with or without an electrical position switch.

## Product Features

- 250 PSI rated epoxy coated ductile iron body and cover
- Tight sealing at low and high pressure
- Flexible disc successfully passed 1 million cycle test
- Stainless steel cover fasteners standard
- Available with backflow device and/or position indicator
- Optional electrical position switch

## Standard Materials

- Body & Cover Ductile Iron, ASTM A536 Grade 65-45-12
- Flexible Disc Buna-N, Nylon and Steel Reinforced
- External Fasteners Type 316 Stainless Steel

## Corrosion Protection

- Standard: Internal and External PPG/Amerlok 400 NSF-61 Certified 2-Part Epoxy, minimum 6 mil DFT



## Approvals & Certifications

- Fully conforms to AWWA Standard C508

## Options/Accessories

- Option 1D With Honeywell Micro Switch NEMA 1, 2, 4, 6, 12 & 13 DPDT Limit Switch (4" to 24", Requires Visual Position Indicator)
- Option PI Visual Position Indicator (4" to 24")

## Ordering Data

- Figure Number (200-D, 200-DBF, 200-DPI or 200-DBFPI)
- Size
- Options and/or Accessories

Non-Shock Working Water Pressure at up to 150F (66C)				
Figure Number	200-D	200-DBF	200-DPI	200-DBFPI
Style	Plain	With Backflow Device	With Visual Position Indicator	With Backflow Device and Visual Position Indicator
Size	2" to 24"	2" to 24"	4" to 24"	4" to 24"
Flange	ANSI B16.1 Class 125			
Max Working Pressure	250 PSI			
Hydro Test	500 PSI			

Data Sheet 200.01D

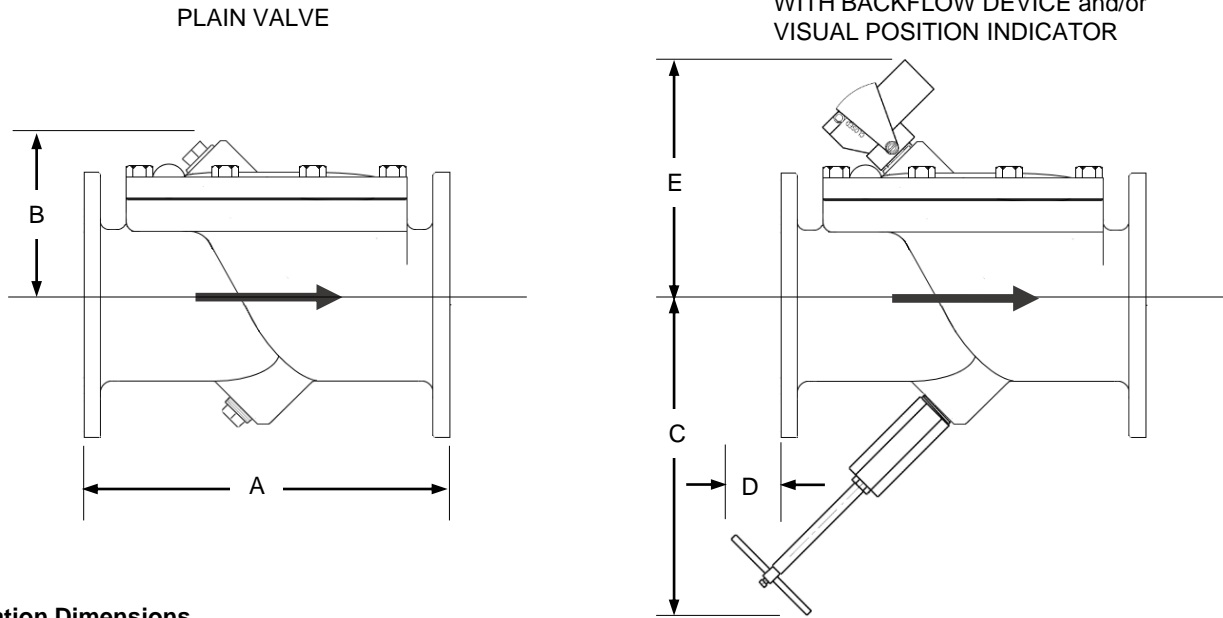

Installation Dimensions

SIZE	2"	2½"	3"	4"	6"	8"	10"	12"	14"	16"	18"	20"	24"
A	8	8½	9½	11½	15	19½	24½	27½	31	32	36	40	48
B	3¾	3¾	5⅝	5¾	6⅝	8⅝	10¾	12½	13	14¼	15¼	16⅝	19¼
C	7	7	8	8	13	17	20	23	27	31	34	38	45
D	0	0	0	2	2	3	4	4	4	5	6	6	7
E	--	--	--	8¾"	9⅞"	11⅞	13½	15¼	15¾	16¾	17¾	19⅝	21¼
WGT	28	33	38	69	125	230	377	615	735	1040	1550	1850	2500

Dimensions in inches, weight in pounds. Dimensions C and D are with backflow device fully retracted.

