

Figure 200-D 30" to 42" Rubber Flapper Check Valve

Description

GA Industries Figure 200-D Rubber Flapper Check Valves have a full 100% flow area for low head loss and clog resistance. Long term reliability is ensured because the valve's reinforced rubber flexible disc is the only moving part and it's integral O-ring provides drop tight sealing at both low and high working pressures.

The valve's 45-degree seat angle, short stroke and its flexible disc's inherent memory combine to provide quick-closing, slam resistant operation.

The Figure 200-D can be supplied with optional backflow device and/or internal spring assisted closure.

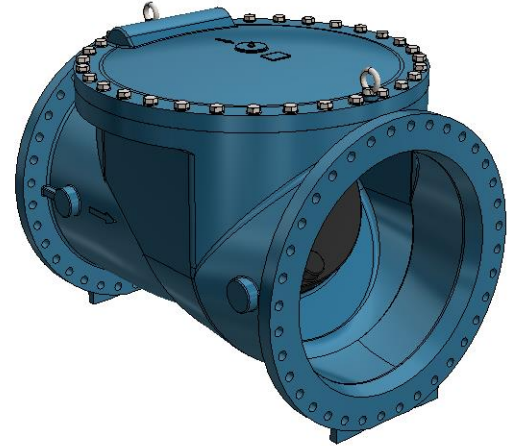

Product Features

- 250 PSI rated epoxy coated ductile iron body and cover
- Tight sealing at low and high pressure
- Flexible disc successfully passed 1 million cycle test
- Stainless steel cover fasteners standard
- Available with backflow device and/or internal spring assist
- Lifting eyes and feet facilitate storage and handling

Standard Materials

- Body & Cover Ductile Iron, ASTM A536 Grade 65-45-12
- Flexible Disc Buna-N, Nylon and Steel Reinforced (Optional EPDM)
- External Fasteners Stainless Steel

Corrosion Protection

- Standard: Internal and External PPG/Amerlok 400 NSF-61 Certified 2-Part Epoxy, minimum 6 mil DFT

Approvals & Certifications

- Fully conforms to AWWA Standard C508

Options/Accessories

- Option BF Backflow Device – allows disc to be manually pushed open to
- Option SG Slaminator® Internal Spring Assist

Ordering Data

- Figure Number (200-D)
- Size
- Options and/or Accessories

Non-Shock Working Water Pressure at up to 150F (66C)				
Figure Number	200-D	200-DBF	200-D-SG	200-DBF-SG
Style	Plain	With Backflow Device	With Slaminator® Internal Spring Assist	With Slaminator® and Backflow Device
Size	30" to 42"			
Flanges	ANSI B16.1 Class 125 / ANSI B16.42 Class 150			
Max Working Pressure	250 PSI			
Hydro Test	500 PSI			

Data Sheet 200.02A

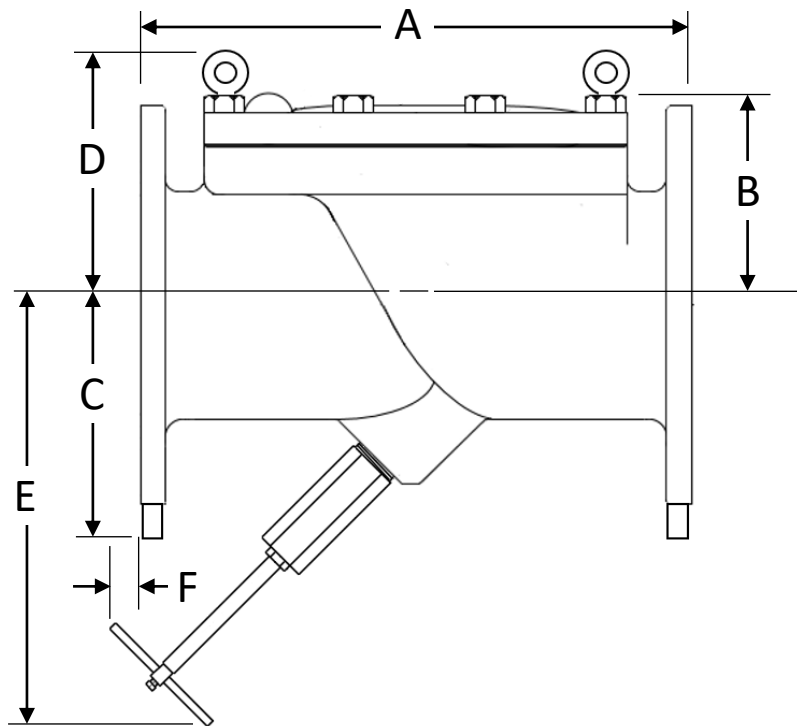

Installation Dimensions

SIZE	30"	36"	42"
A	60	RTF	71 $\frac{3}{8}$
B	23 $\frac{1}{2}$	RTF	30 $\frac{7}{8}$
C	21 $\frac{1}{8}$	RTF	26 $\frac{3}{8}$
D	25	RTF	32 $\frac{7}{8}$
E	Refer to Factory		
F	Refer to Factory		
WGT	3,400	RTF	8,400

Dimensions in inches, weight in pounds and are approximate. Request certified drawing if critical. Dimensions E and F are with backflow device fully retracted.