

Figures 220-D, 220-U Lever & Weight Swing Check Valves

Description

GA Industries Figures 220-D and 220-U heavy duty, customizable swing check valves employ an adjustable counterweight for reliable non-slam operation.

These valves are installed on the discharge of a pump to prevent backflow when the pump is offline, opening smoothly at pump start and closing quickly and quietly upon pump shutdown.

Especially designed to withstand the rigors of pump station operation, and especially well suited for use on VFD pumping applications, the Figures 220-D and 220-U meet the design, materials of construction and testing required by AWWA C508 and are suitable for use with water or sewage.

Product Features

- Opens to full flow area when swung only 25° away from seat for low head loss and reduced pumping cost
- Durable and replaceable rubber disc seat for tight sealing
- Bolted cover allows access to all internal components
- Lever & weight field convertible right hand to left hand side and from horizontal to vertical installation

Standard Materials

- Body & Disc Cast Iron, ASTM A126 Class B
- Cover Steel, ASTM A36
- Body Seat Stainless Steel, Type 316
- Disc Seat Buna-N
- Hinge Shaft Stainless Steel, Type 303
- Cushion Chamber Bronze
- External Fasteners Steel, A307, Zinc Plated
- Coating Internal and external NSF-61/600 certified 2-part epoxy

Non-Shock Working Water Pressure at up to 150F (66C)		
Figure No.	220-D	220-U
Flange	ANSI B16.1 Class 125	ANSI B16.1 Class 250
Size	30" & 36"	30" & 36"
Max Working Pressure	150 PSI	300 PSI
Shell Test	300 PSI	450 PSI

See Data Sheet 220.01 for smaller sizes

Data Sheet 220.02D

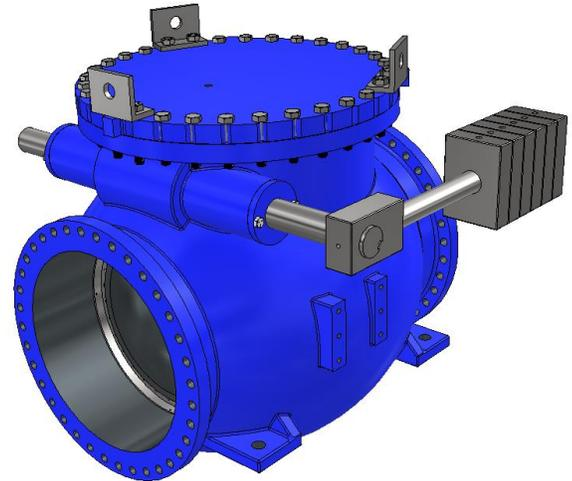

Approvals & Certifications

- NSF-61 Certified for Contact with Drinking Water
- NSF-372 Certified Lead Free (Max 0.25% Lead Content by Weighted Average)
- AIS and BABA Compliant

Options

- Option 1D With Honeywell HDLS NEMA 1, 3, 4, 4X, 6, 6P, 12 & 13 DPDT Limit Switch
- Option LH With Lever & Weight Factory Installed on Left Side Facing Inlet
- Option P3 With 316 SS Hinge Shaft, Disc Center Pin, Lock Nut and Washer, Shaft End Plate and External Fasteners
- Option S3 With Type 316 Stainless Steel Hinge Shaft (Included in Option P3)
- Option SE With 316 Stainless Steel External Fasteners (Included in Option P3)
- Option VI Configured for Vertical Flow Up Installation

Ordering Data

- Figure Number (220-D or 220-U)
- Size
- Options and/or Accessories

Data Sheet 220.02D

DUAL COUNTERWEIGHTS AND ARMS
SUPPLIED ONLY WHEN NEEDED

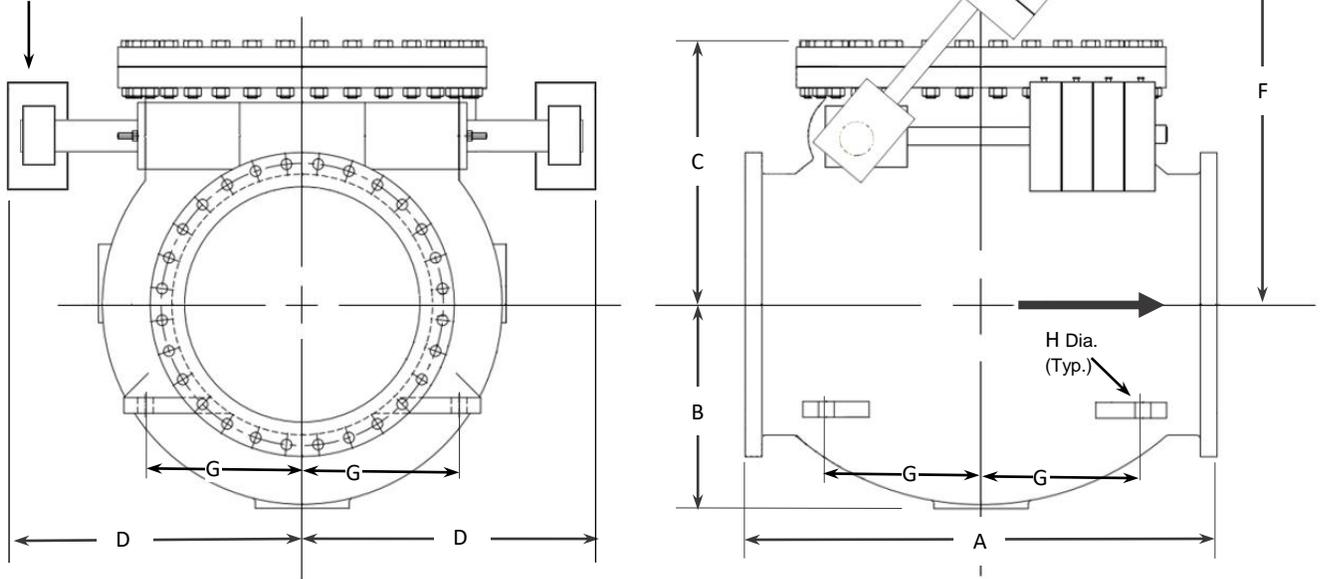

Installation Dimensions

SIZE	A	B	C	D	F	G	H	WGT
30"	60	26	33	34½	57	20	2	8,000
36"	63	30	33	44	60	22¾	2	13,000

- Dimension F is valve fully-open.
- Face to face same for both Class 125 and Class 250 flanged valves, Class 250 supplied with flat face.
- Dimensions in inches, weight in pounds and are approximate. Request certified drawings if critical..

Vertical Installation

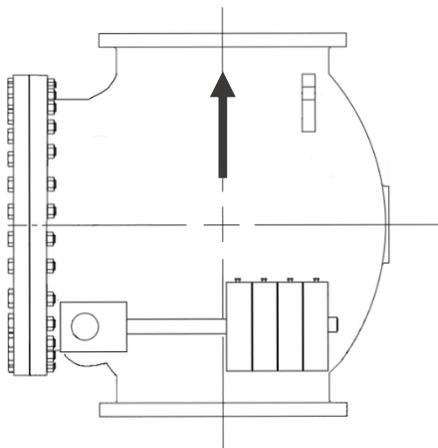

Full Open Head Loss

