

# INSTALLATION, OPERATION AND MAINTENANCE MANUAL

## Figures 230-D and 230-U 16” to 20” Lever & Spring Swing Check Valves Drawing C- 1449

### TABLE OF CONTENTS

Introduction .....	1
Description of Operation .....	1
Receiving & Storage .....	1
Installation .....	1
Valve Construction .....	1
Start-Up .....	2
Preventive Maintenance .....	2
Trouble Shooting .....	2
Disassembly .....	2
Assembly .....	3
Replacement Parts .....	3
Warranty .....	3
Assembly Drawing/Parts Location .....	4



**234 Clay Avenue • Mars, PA 16046 USA**  
**Telephone (724) 776-1020 • Fax (724) 776-1254**  
**E-mail: [info-ga@vag-group.com](mailto:info-ga@vag-group.com)**

Manual Number 230.1-IOM-051921



**WARNING: Cancer and Reproductive Harm – [www.Prop65Warnings.ca.gov](http://www.Prop65Warnings.ca.gov)**

# INSTALLATION, OPERATION and MAINTENANCE

## 16" to 20" Figures 230-D and 230-U Lever & Spring Swing Check

### INTRODUCTION

This manual will provide the information to properly install, operate and maintain the valve to ensure a long service life. The Figure 230 Swing Check Valve is ruggedly constructed to provide years of trouble-free operation with minimal maintenance.

#### CAUTION

The valve is NOT recommended for use with toxic or highly corrosive fluids, fuels or fluids containing hazardous gases

The Shop Order (SO) Number, Figure Number, size and pressure rating are stamped on a nameplate attached to the valve. Please refer to the SO number when ordering parts.

### DESCRIPTION OF OPERATION

The Figure 230 Swing Check Valve is a spring-assisted, rubber- or metal-seated check valve designed to permit flow in one direction and close to prevent reverse flow. The valve opens when the inlet pressure exceeds the outlet pressure. The degree of opening depends on the fluid velocity through the valve. The valve will swing closed as fluid velocity decreases and be fully seated before flow reversal precluding slam and bang.

### RECEIVING AND STORAGE

Inspect the valve upon receipt for damage during shipment. Carefully unload all valves to the ground without dropping.

The valves should remain in a clean, dry and weather protected area until installed. For long term storage (greater than 6 months) the rubber surfaces of the seat should be coated with a non-toxic lubricant such as "SuperLube" made by Synco Chemical. Do not expose the rubber parts to sunlight or ozone.

### INSTALLATION

Figure Numbers suffixed with "D" indicated the valve has ANSI Class 125 flanged connections, Figure Numbers suffixed with "U" indicate the valve has ANSI Class 250 flanged connections.

Consult the drawings of record to verify the configuration supplied and installed.

Prior to installation ensure all debris, packing material or other foreign material has been removed from both ports.

Install the valve in the proper flow direction. Forward flow should tend to open the valve. The valve can be installed in a horizontal or vertical (upward flow direction) pipe.

If installed outdoors, below ground in a vault or in an unheated area, adequate freeze protection must be provided.

Adequate isolating valves should be installed between the valve and the pipeline or system to facilitate maintenance.

Installation immediately downstream of an elbow or a significant increase in pipe size may produce uneven or turbulent flow through the valve and lead to premature wear. Consult factory for recommendations.

The valve is not designed to support adjacent equipment, piping loads should not be imposed on the valve and large valves should be properly supported. Ensure mating flanges are square and parallel to the valve flanges before tightening flange bolts.

Flat-faced flanged valves should be mated with flat-faced flanges and full-face gaskets. If ring gaskets are used the bolt material shall be ASTM A307 Grade B (or equivalent). Higher strength bolting should only be used with full-face gaskets.

Lower heavy valves using slings or chains around the valve body and/or the lifting eye. Lubricate the bolts or studs and insert around flange. Lightly tighten bolts until gaps are eliminated. Torque bolts in an alternating pattern in graduated steps. If leakage occurs wait 24 hours and re-torque the bolts but do not compress the gasket more than 50% or exceed bolt maximum torque rating.

### VALVE CONSTRUCTION

The standard Series 230 Swing Check Valve has a cast iron body, bronze or stainless steel (indicated by Figure Number suffixed with "S") body seat, stainless steel hinge shaft and cast iron disc with a rubber disc

seat. An "M" suffixed to the Figure Number (e.g., 230-DM, 230-USM) indicates optional metal-to-metal seating was supplied. Refer to the List of Materials submitted for the order if non-standard materials were provided.

Refer to Page 4 for details of construction and parts location.

### START-UP

The valve generally does not require any calibration or adjustment prior to start-up. The spring compression is factory set to accommodate most operating conditions.

The valve should smoothly swing open as flow through the valve increases. The amount of opening depends on the flow velocity through the valve and can be observed by watching the action of the spring arm. The valve is "full ported" at about 25 degrees of swing but can swing open as much as 60 degrees.

Shut down the pump and observe the valve's closure. If the valve was less than 60 degrees open and the closure was smooth and quiet then the spring compression may be decreased by turning the spring rod nut (44) counterclockwise. If the valve slams, increase the spring compression by turning the spring rod nut (44) clockwise. Repeat these steps to the point where the valve opens to the extent possible but still closes quietly.

Non-slam operation is achieved when the spring pulls the valve fully closed prior to flow reversal.

### PREVENTIVE MAINTENANCE

Figure 230 Swing Check Valves require no scheduled lubrication, adjustment or preventive maintenance.

A monthly inspection should be performed for the first 6 months of operation to ensure the valve is functioning properly and there is no external fluid leakage or audible evidence of water leaking backwards through the closed valve.

Thereafter, a quarterly visual inspection should be performed.

### TROUBLESHOOTING

- Shaft packing leakage  
Tighten packing gland nuts equally just enough to stop leakage, no more than ½ turn at a time. DO NOT OVER-TIGHTEN!  
Replace packing if necessary.
- Leakage past seat when closed  
Inspect valve for debris, clean  
Inspect seating surfaces for damage, replace as necessary
- Leakage past cover or flange gaskets  
Tighten cover or flange bolts
- Disc oscillating when open  
Decrease spring tension

- Valve slams upon closing  
Increase spring tension  
Ensure shaft packing is not too tight

<p style="text-align: center;"><b>WARNING</b></p> <p>Removing the valve from the line or disassembling the valve while there is pressure in the valve body may result in injury or damage to the valve</p>
--

<p style="text-align: center;"><b>WARNING</b></p> <p>Follow all applicable safety regulations and codes and read and understand all instructions before undertaking disassembly.</p>
--

### DISASSEMBLY

All Figure 230 valves can be serviced while the body remains connected to the pipeline. A skilled technician should perform all work. No special tools are required.

First ensure there is no pressure within the valve and operating equipment is tagged and locked out. Refer to page 4 for parts identification and location.

It is not necessary to disassemble the entire valve to replace the shaft packing, follow steps 1, 6, 5a & 6a..

1. Ensure there is no pressure within the valve and operating equipment is locked out.
2. Accurately measure and note the distance from the end of the spring rod (43) to the spring rod nut (44).
3. Remove the spring rod nut (44), spring rod washer (44A), spring support (42) and spring (41).
4. Remove the lever pin cotter pins (47) and the spring lever pin (46). While supporting the spring chamber (40), remove the spring assembly screws (49) and the spring chamber with the spring rod inside.
5. Loosen spring lever set screw (48) and slide the lever off the shaft (11) being careful not to lose the spring lever key (45A).
6. Loosen and remove the gland stud nuts (16), slide off the gland (15) and remove the shaft packing (17).
7. Remove the end plate bolts (35), the end plate (34) being careful not to lose or damage the end plate seal (36) unless it is to be replaced
8. Remove the cover bolts (10) and lift off the cover (9). If necessary, carefully pry the cover off using a cold chisel between the body and cover. Be careful not to damage or lose the cover gasket (8) unless it is to be replaced.
9. Remove the shaft lock pin (18) by threading a screw into the tapped hole.
10. With the disc and disc arm properly supported, loosen the disc arm set screw (12) and pull the shaft (11) out of the valve.

It may be necessary to drive out the shaft from the opposite end.

NOTE: The outer bushing (14) and disc arm key (19) should come out with the shaft. Be careful not to lose the disc arm key. After the shaft is out, remove the inner bushing (13) from the opposite side.

11. Carefully lift the disc arm assembly out of the body. Remove the disc nut pin (6B), disc nut (6) and disc nut washer (6A).
12. Remove the seat screws (5C), the seat follower (5B) and the renewable seat (5A) or metal seat washer (5D).
13. In the unlikely event it's necessary to remove the body seat (2), the spring pins holding it into the body must be compressed until they no longer "bite" into the body. This is best accomplished by compressing the seat pins (2B) using "vice-grips" and pulling the pins in a radial direction towards the valve centerline.

Inspect all parts for wear and damage. Replace damaged parts.

**ASSEMBLY**

The valve is reassembled by reversing the disassembly sequence with consideration of the following:

- 1a. Clean and polish all machined bearing and sealing surfaces. Apply a light coat of lubricant to assist in the assembly.
- 2a. Ensure the disc arm key slides inside the disc arm before installing the shaft lock pin (18). Ensure the shaft lock pin has dropped into the groove provided for it on the shaft.
- 3a. Install the inner and outer bushings then install the shaft packing. Install the end plate (34) with seal (36). Install and tighten the end plate bolts (35) while ensuring the end plate seal (36) remains in the groove provided for it in the end plate.
- 4a. Lift the disc assembly several times to ensure free closure with no metal-to-metal contact.
- 5a. Wrap the packing around the shaft and cut on a 45-degree angle, staggering the cuts with each ring.
- 6a. Tighten gland bolts evenly until packing is slightly compressed. After pressure has been introduced into the valve, re-tighten evenly until leakage stops.
- 7a. Ensure cover gasket sealing surfaces are clean and apply a thin coat of Permatex™ #2 to both surfaces. Tighten cover nuts in an alternating pattern. Re-tighten as needed after pressure has been introduced.
- 8a. Re-install the spring lever (45) with key (45A) and tighten spring arm set screw (48).
- 9a. Align spring rod eye with spring lever and install pin (46) and cotter pins (47).

- 10a. Position spring chamber (40), install and tighten spring assembly screws (49).
- 11a. Install spring (41), spring support (42), spring rod washer (44A) and spring rod nut (44). Tighten spring rod nut until spring is compressed to the distance measured in step 2.

**REPLACEMENT PARTS**

Genuine replacement parts are available from your local VAG/GA Industries representative or from the factory:

VAG USA, LLC  
 234 Clay Avenue  
 Mars, PA 16046 USA  
 Telephone: 724-776-1020  
 Fax: 724-776-1254  
 E-mail: [quotes-ga@vag-group.com](mailto:quotes-ga@vag-group.com)

Please have the nameplate data available when ordering parts. Identify needed part(s) by Shop Order (SO) Number, Figure Number, valve size and individual part number.

**REPAIR KITS**

Soft Goods Kit includes Items 2A 5A, 8, 17 & 36

Size	Kit Number	Part Number
16"	SW16	2-80-24000-209
18"	SW1820	2-80-24000-212
20"		

Soft Goods AND Disc/Disc Arm Assembly Kit includes above parts plus 3, 4, 5B, 5C, 6, 6A, 6B & 12.

Size	Kit Number	Part Number
16"	SW16D	2-80-24000-211
18"	SW1820D	2-80-24000-213
20"		

All other parts ordered individually. Consult factory for larger sizes.

**WARRANTY:**

The Warranty for GA Industries valves is included in our Terms and Conditions which can be found here: <https://gaindustries.com/terms>

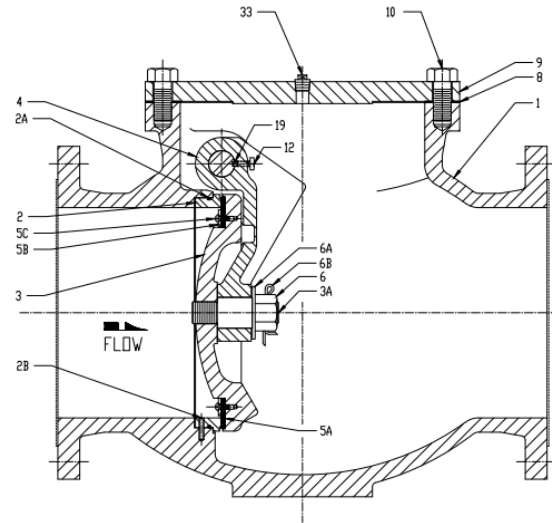
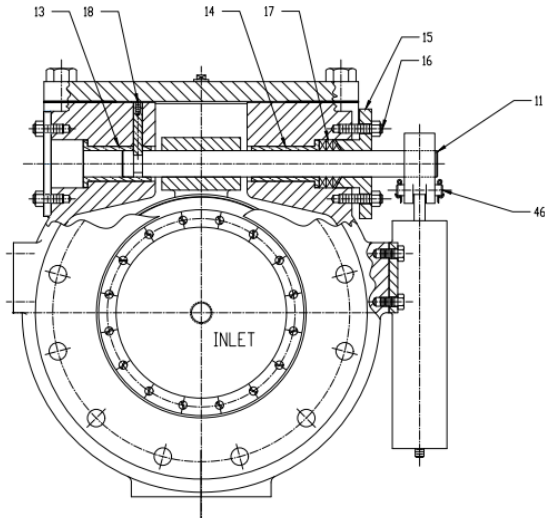

**PARTS IDENTIFICATION & LOCATION**

Part No.	Part Name	Std. Material
1	Body	Cast Iron
2	Body Seat	Bronze or SS
2A	Seat O-Ring	Buna-N
2B	Seat Pins	Stainless Steel
3	Disc with Center Pin	Cast Iron/Steel
4	Disc Arm	Ductile Iron
5A	Renewable Seat	Buna-N
5B	Seat Follower	Bronze or SS
5C	Seat Screws	Stainless Steel
5D	Metal Seat Washer (Opt'l)	Bronze or SS
6	Disc Nut	Steel
6A	Disc Nut Washer	Steel
6B	Disc Nut Cotter Pin	Stainless Steel
8	Cover Gasket	Fiber
9	Cover	Steel
10	Cover Bolt (and Nut)	Steel
11	Shaft	Stainless Steel
12	Disc Arm Set Screw	Stainless Steel
13	Inner Bushing	Bronze
14	Outer Bushing	Bronze
15	Gland	Cast Iron
16	Gland Stud & Nut	Steel
17	Packing	Teflon
18	Shaft Lock Pin	Brass
9	Disc Arm Key	Stainless Steel
40	Spring Chamber	Steel
41	Spring	Steel
42	Spring Support	Steel
43	Spring Rod	Stainless Steel
43A	Spring Rod End	Steel
43B	Anti Rotation Pin	Stainless Steel
44	Spring Rod Nut	Stainless Steel
44A	Spring Rod Washer	Stainless Steel
45	Spring Lever	Steel
45A	Spring Lever Key	Steel
46	Spring Lever Pin	Stainless Steel
47	Cotter Pins	Stainless Steel
48	Spring Lever Set Screw	Steel
49	Spring Chamber Screw	Steel
50	Spring Rod Bearing	Bronze

