

Figures 250-D, 250-U 30" & 36" Air Cushioned Swing Check Valves

Description

GA Industries Figures 250-D and 250-U heavy duty, customizable swing check valves utilize an adjustable counterweight for rapid closure combined with a highly engineered air cushion chamber to provide non-slam operation under all operating conditions.

Typically installed on the discharge of a pump to prevent backflow when the pump is offline, it opens smoothly at pump start and closes quickly and quietly upon pump shutdown. These check valves are ideal for VFD pumping.

Especially designed to withstand the rigors of pump station operation, the Figures 250-D and 250-U meet the design, materials of construction and testing required by AWWA C508 and are suitable for use with water or sewage.

Product Features

- Unique disc design affords 360-degree articulation for tight sealing under all pressure conditions.
- Durable and replaceable rubber seat for tight sealing
- Opens to full flow area when swung only 25° away from seat for low head loss and reduced pumping cost
- Bolted cover allows access to all internal components
- Lever & weight and air cushion field convertible right hand to left hand side and from horizontal to vertical installation

Standard Materials

- Body & Disc Cast Iron, ASTM A126 Class B
- Cover Steel, ASTM A36
- Body Seat Stainless Steel, Type 316
- Disc Seat Buna-N
- Hinge Shaft Stainless Steel, Type 303
- Cushion Chamber Bronze
- External Fasteners Steel, A307, Zinc Plated
- Coating Internal and external Carboguard 891 NSF-61 certified 2-part epoxy

Non-Shock Working Water Pressure at up to 150F (66C)		
Figure No.	250-D	250-U
Flange	ANSI B16.1 Class 125	ANSI B16.1 Class 250
Size	30" & 36"	30" & 36"
Max Working Pressure	150 PSI	300 PSI
Shell Test	300 PSI	450 PSI

See Data Sheet 250.01 for smaller sizes

Data Sheet 250.02C



Approvals & Certifications

- NSF-61 Certified for Contact with Drinking Water
- NSF-372 Certified Lead Free (Max 0.25% Lead Content by Weighted Average)
- AIS and BABA Compliant

Options

- Option 1D With Honeywell HDLS NEMA 1, 3, 4, 4X, 6, 6P, 12 & 13 DPDT Limit Switch
- Option LH With Lever & Weight Factory Installed on Left Side Facing Inlet
- Option P3 With 316 SS Hinge Shaft, Disc Center Pin, Lock Nut and Washer, Shaft End Plate and External Fasteners
- Option S3 With Type 316 Stainless Steel Hinge Shaft (Included in Option P3)
- Option SE With 316 Stainless Steel External Fasteners (Included in Option P3)
- Option VI Configured for Vertical Flow Up Installation

Ordering Data

- Figure Number (250-D or 250-U)
- Size
- Options and/or Accessories

Data Sheet 250.02C

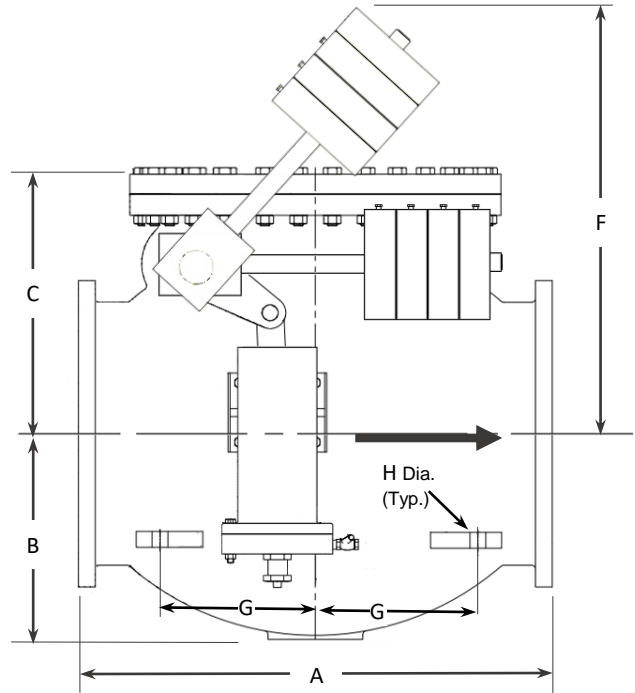
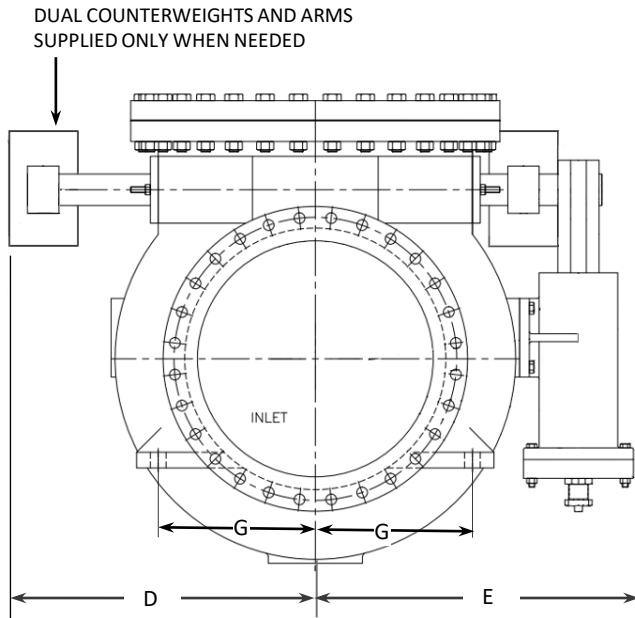

Installation Dimensions

SIZE	A	B	C	D	E	F	G	H	WGT
30"	60	26	33	34½	43	57	20	2	8,200
36"	63	30	33	44	45	60	22¾	2	13,500

- Dimension F is valve fully-open.
- Face to face same for both Class 125 and Class 250 flanged valves, Class 250 supplied with flat face.
- Dimensions in inches, weight in pounds and are approximate. Request certified drawings if critical.

Vertical Installation

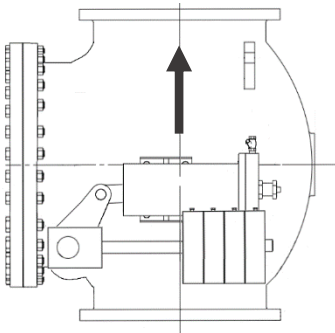

Full Open Head Loss

