

# Figures 250-DOC and 250-UOC Oil-Cushioned Swing Check Valve

## Description

GA Industries Figures 250-DOC and 250-UOC are heavy duty, customizable swing check valves that utilize an adjustable counterweight for rapid closure combined with a highly engineered oil cushion chamber to provide non-slam operation.

Typically installed on the discharge of a pump to prevent backflow when the pump is offline, it opens smoothly at pump start and closes quickly and quietly upon pump shutdown.

Especially designed to withstand the rigors of pump station operation, Figures 250-DOC and 250-UOC meet the design, materials of construction and testing required by AWWA C508 and are suitable for use with water or sewage.

## Product Features

- Unique disc design affords 360-degree articulation for tight sealing under all pressure conditions
- Opens to full flow area when swung only 25° away from seat for low head loss and reduced pumping cost
- Bolted cover allows access to all internal components
- Lever & weight and side-mounted adjustable oil cushion
- Oil cushion can be serviced/removed without depressurizing or draining the valve

## Standard Materials

- Body & Disc Cast Iron, ASTM A126 Class B
- Cover Steel, ASTM A36
- Body Seat Stainless Steel, Type 316
- Disc Seat Buna-N
- Hinge Shaft Stainless Steel, Type 303
- Oil Cushion Stainless Steel
- External Fasteners Steel, A307, Zinc Plated
- Coating Internal and external NSF-61/600 certified 2-part epoxy

Non-Shock Working Water Pressure at up to 150F (66C)		
Figure No.	220-DOC	220-UOC
Flange Drilling	ANSI B16.1 Class 125	ANSI B16.1 Class 250
Size	2" to 24"	2" to 24"
Max Working Pressure	200 PSI	300 PSI
Shell Test	400 PSI	450 PSI

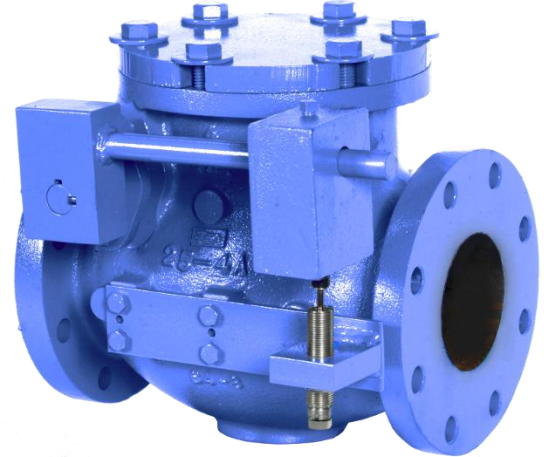

## Approvals & Certifications

- NSF-61 Certified for Contact with Drinking Water
- NSF-372 Certified Lead Free (Max 0.25% Lead Content by Weighted Average)

## Options

- Option 1D With Honeywell HDLS NEMA 1, 3, 4, 4X, 6, 6P, 12 & 13 DPDT Limit Switch
- Option LH With Lever & Weight Factory Installed on Left Side Facing Inlet
- Option P3 With 316 SS Hinge Shaft, Disc Center Pin, Lock Nut and Washer, Shaft End Plate and External Fasteners
- Option S3 With Type 316 Stainless Steel Hinge Shaft (Included in Option P3)
- Option SE With 316 Stainless Steel External Fasteners (Included in Option P3)
- Option VI Configured for Vertical Flow Up Installation

## Ordering Data

- Figure Number (250-DOC or 250-UOC)
- Size
- Options and/or Accessories

Data Sheet 250OC.01H

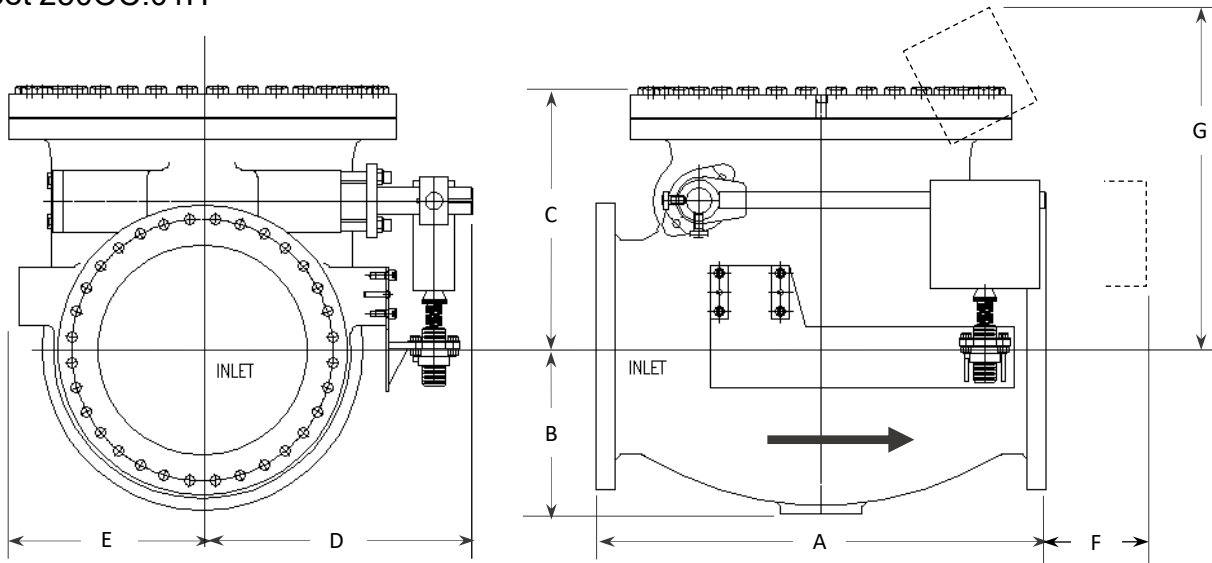

**Installation Dimensions**

SIZE	3"	4"	6"	8"	10"	12"	14"	16"	18"	20"	24"	30"	36"	42"	48"
A	12	13	17½	18	23	28	33	36	40	40	48	60	63	70	76
B	7	8½	9	12	14	16	22	23	24	24	28	26	30	33	36
C	5	5	6	9	9	11	13	14	17¼	17¼	20	33	36	40	46
D	10	11	12	14	15	17	20	24	28	28	34	41	43	46	50
E	5	5	7	8	9	11	14	16	18	18	21	32	34	33	41
F	5	4	3	3	--	8	--	-	--	--	1½	--	--	--	--
G	15	16	19	21	23	32	34	35	37	37	44	46	48	52	60
WGT	101	154	234	310	485	970	1480	1860	2400	2800	6000	8200	13500	20000	28000

- Dimension F is distance counterweight extends past outlet flange face when closed
- Dimension G is valve fully open,
- Dimensions in inches, weight in pounds and are approximate. Request certified drawings if critical.
- Dual counterweight arms and oil cushions available, consult factory.

**Full Open Headloss**

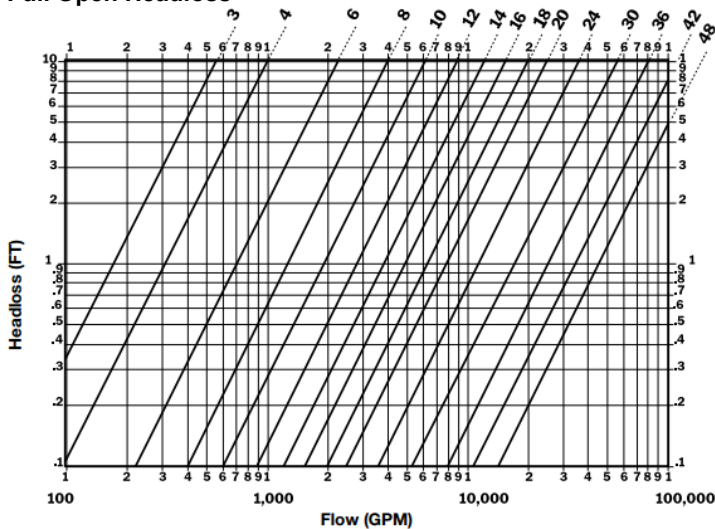

**Vertical Installation**

