

INSTALLATION, OPERATION AND MAINTENANCE MANUAL

24” to 60” Figure 517R Rectangular Port Plug Valves

TABLE OF CONTENTS

Introduction	1
Function	1
Receiving & Storage	1
Installation	1
Operation	1
Valve Construction	2
Start Up	2
Preventive Maintenance	2
Trouble Shooting	2
Shaft Packing Replacement	2
Disassembly	3
Assembly	3
Replacement Parts List	3
Warranty	3
Assembly Drawing/Parts Identification..	4



234 Clay Avenue • Mars, PA 16046 USA
Telephone (724) 776-1020 • Fax (724) 776-1254
E-mail: info-ga@vag-group.com

Manual Number 517R-IOM-021826



WARNING: Cancer and Reproductive Harm – www.Prop65Warnings.ca.gov

INSTALLATION, OPERATION and MAINTENANCE

GA Industries Figure 517R Rectangular Port Plug Valves

INTRODUCTION

This manual will provide the information to properly install, operate and maintain the valve to ensure a long service life. The GA Industries Figure 517R Eccentric Plug Valves are ruggedly constructed to provide years of trouble-free operation with minimal maintenance.



WARNING

The valve is NOT recommended for use with toxic or highly corrosive fluids, fuels or fluids containing hazardous gases

The Shop Order (SO) Number, Figure Number, size and pressure rating are stamped on a nameplate attached to the valve. Please refer to the SO number when ordering parts.

FUNCTION

Figure 517R Eccentric Plug Valves are typically either fully open or fully closed to isolate pipelines and equipment in sewage and wastewater pipelines and treatment plants or on sludge lines in water treatment plants. The valve can also be positioned partially open to throttle flow. It can be manually operated by turning the handwheel or 2" operating nut on the worm gear actuator or automatically by an electric motor, pneumatic or hydraulic actuator. The valve is designed to accommodate solids and other matter that may be present in sewage and sludge systems without clogging.

RECEIVING AND STORAGE

Inspect the valve upon receipt for damage during shipment. Carefully unload all valves to the ground without dropping.

The valves should remain in a clean, dry, and weather protected area until installed.

The valves should be stored with the plug partially open. Replace any flange protectors that were removed for receipt inspection.

INSTALLATION

These valves are large, heavy, and awkward to handle. Ensure proper handling techniques are employed. Handle heavy valves using slings around the valve body and/or by the lifting eyes. Do not lift by the actuators or by slings or chains through the port openings.

Prior to installation ensure all debris, packing material or other foreign material has been removed from both ports.

Before installing, open and close the valve to ensure proper operation. Close valve before installing in pipeline.

The valve is not designed to support adjacent equipment and all piping must be supported to avoid imposing stress on the valve. Do not "jack" mating pipes into position.

The valve should be oriented with the "Seat End" in the proper direction. While the valve can operate with flow in either direction it is typically installed with the seat end on the downstream side of the flow.

When installed in horizontal pipes with fluids containing suspended solids it is preferred, but not necessary, to install the valve with the plug shaft horizontal so that the plug rotates up and out of the flow path when open.

When installed in vertical pipes with suspended solids, the valve should be installed with the seat end on the top side of the valve regardless of the flow direction

Ensure mating flanges are square and parallel to the valve flanges before tightening flange bolts. Prepare pipe ends according to pipe manufacturer's instructions when installing mechanical joint end valves.

Do not backfill buried service valves until after the system is tested.

Flanged valves should be mated with flat-faced flanges and full-face gaskets. If ring gaskets are used the bolt material shall be ASTM A307 Grade B (or equivalent). Higher strength bolting should only be used with full-face gaskets.

Lubricate the bolts or studs and insert around flange. Lightly tighten bolts until gaps are eliminated. Torque bolts in an alternating pattern in graduated steps. If leakage occurs wait 24 hours and re-torque the bolts but do not compress the gasket more than 50% or exceed bolt maximum torque rating.

Do not test systems to pressures higher than the 150 PSI rated pressure.

Before putting into service open all valves completely and thoroughly flush system to avoid damaging the valve seat by closing on construction debris.

OPERATION

The Figure 517R opens and closes through a 90-degree "eccentric" rotation. During opening, the initial rotation causes the rubber coated plug to pull "out of the seat" and rotation continues without seat contact minimizing wear. When fully open the plug is out of the main flow path for low headloss but can be positioned partially open for throttling applications. During closing, the plug initially rotates without seat contact but rotates "into the seat" at the end of travel making a tight seal.

There are no travel stops in the valve itself. The full open and full closed travel stops are in the actuator and are adjustable.

On standard gear operated valves, turning the handwheel or operating nut clockwise closes the valve and counterclockwise opens the valve.

VALVE CONSTRUCTION

The standard Figure 517R Eccentric Plug Valves have an epoxy lined and coated ductile iron body and cover, a pure nickel weld overlaid body seat and a ductile iron plug with Buna-N rubber facing.

Refer to the List of Materials submitted for the order if non-standard materials were provided.

Refer to Page 4 for details of construction and parts location.

START-UP

The valve generally does not require any calibration or adjustment prior to start-up. The open and close travel stops are set at the factory but may change during transportation and handling. If the valve does not seat tightly when closed, the close travel stop can be adjusted to allow the plug to rotate farther into the seat.

CAUTION: Excessive closing force or travel can damage the valve or actuator if there is debris preventing a tight seat. Before adjusting the travel stop open the valve to flush out any debris that may be lodged in the valve.

PREVENTIVE MAINTENANCE

Figure 517R Eccentric Plug Valves are designed to remain in one position for long periods of time, but regular exercise is recommended for valves that are not frequently operated.

There are no lubrication requirements.

Plug valves should be visually inspected for leaks and close/open cycled under pressure semi-annually.

TROUBLESHOOTING

- Leakage at Flange Joint
 - Tighten bolts but do not over-torque
 - Replace gasket
- Leakage at Shaft Packing
 - Tighten packing gland
 - Replace packing
- Seat Leakage
 - Debris on seat: Open valve to flush
 - Rotate farther closed: Adjust close stop
 - Damaged plug: Replace
- Difficult to Operate
 - Gland too tight: Loosen gland
 - Grit in bearings: Disassemble, inspect, clean or replace bearings



WARNING

Removing the actuator from the valve or disassembling the valve while there is pressure in the valve body may result in injury or damage to the valve



WARNING

Follow all applicable safety regulations and codes and read and understand all instructions before undertaking disassembly.

REPLACING SHAFT PACKING WITHOUT REMOVING THE ACTUATOR

The shaft packing (10) in exposed valves can be replaced without removing the actuator.

1. Ensure there is no pressure within the valve and operating equipment is locked out.
2. Loosen or remove the gland nuts (12) so the gland (11) can be sufficiently lifted to access the packing
3. Using a pick, lift the packing rings, cutting them to remove from the plug shaft.
4. Clean the packing box and blow out any debris
5. The packing consists of a bottom male adaptor, several V-rings, and a top female adaptor.



6. Using a razor knife, cut the bottom (male) packing ring on a 45-degree angle. Lubricate the ring and install into the bottom of the packing box as shown above.
7. Cut the V-rings on a 45-degree angle, lubricate and install with the point of the "V" pointing toward the actuator, staggering the cut joints.
8. Cut the top (female) packing ring on a 45-degree angle, lubricate and install.
9. Push the packing set into the packing box using the gland until the packing set is fully seated.
10. Install and tighten the gland nuts (12) until they just touch the gland (11) and then one more full turn.
11. Reintroduce pressure and check for leaks. If a leak is noticed, evenly tighten the gland nuts (12) just until the leak stops. Excess compression will increase operating torque and shorten the packing life.

REPLACING SHAFT PACKING AFTER REMOVING THE ACTUATOR

1. Scribe or mark the actuator and cover for proper alignment upon reassembly.
2. Ensure there is no pressure within the valve and operating equipment is locked out.



WARNING

If the valve is installed in a vertical pipe or in a horizontal pipe with the plug shaft horizontal, the plug may swing downward when the actuator is removed. Rotate the plug to the lowest position before removing the actuator

3. Remove the gland bolts (12) and gland (11). Using a pick, lift and remove the packing rings.

4. Clean the packing box and blow out any debris
5. Lubricate and install the bottom (male) adaptor ring over the shaft.
6. Lubricate and install the V-rings with the point of the "V" pointing toward the actuator.
7. Lubricate and install the top (female) adaptor ring.
8. Push the packing set into the packing box using the gland until the packing set is fully seated.
9. Install and tighten the gland bolts (12) until they just touch the gland (11) and then one more full turn.
10. Reintroduce pressure and check for leaks. If a leak is noticed, evenly tighten the gland bolts (12) just until the leak stops. Excess compression will increase operating torque and shorten the packing life.

DISASSEMBLY

To disassemble/re-assemble the valve the plug shaft must be vertical. It may be necessary to remove the valve from the pipeline and rotate so that it is sitting on a solid surface.

Before removing the valve, ensure operating equipment is tagged and locked out and there is no pressure within the valve. Pressure can be relieved by removing the pipe plug (13) in the valve cover. Drain or remove the liquid from the valve.



WARNING

The cover may blow off the top of the valve if the cover bolts are removed with pressure inside the valve. Remove ALL pressure before disassembly

Refer to page 4 for parts identification and location.

A skilled technician should perform all work. No special tools are required.

1. If disassembling in-line, ensure there is no pressure within the valve and operating equipment is locked out. If possible, drain the liquid from the valve.
2. Close the valve.
3. Scribe or mark the actuator and cover for proper alignment upon reassembly.
4. Remove the fasteners used to mount the actuator to the adapter (6) and lift off the actuator, making sure not to lose the keys, couplings, etc. for reassembly.
5. Remove the adapter (6) mounting bolts and lift off the adapter.
6. Remove the gland bolts (12) and gland (11). Using a pick, remove the packing set (8).
7. Scribe or mark the bonnet/cover (3) and body (1) for proper alignment upon reassembly.
8. Remove the cover bolts (4).
9. Install two eyebolts in opposite holes in the cover's actuator mounting flange. Lift the cover straight up and off the plug shaft. Remove the cover O-ring (5).
10. Remove the plug (2) by turning and lifting out of the body.
11. Inspect the upper and lower bearings (9 & 16) and the upper and lower thrust bearings (7 & 18) and grit excluders (8 & 17) for wear. Replace if needed. It may be necessary to remove the bottom cover (13) to extract the lower bearing and bushing.

12. Inspect the plug's rubber coating for wear, tears, and other damage. Replace if necessary.
13. Inspect the welded nickel seating surface in the body. Minor smooth-edged dents and nicks can be accommodated by the plug's rubber coating, but significant sharp-edged gouges, dents and nicks may necessitate replacing the entire valve.

ASSEMBLY

The valve is reassembled by reversing the disassembly sequence with consideration of the following:

1. Clean and polish all machined bearing and sealing surfaces. Apply a light coat of lubricant to assist in the assembly.
2. Install lower shaft bearing (16) into the bottom of body. Lubricate and place the lower grit excluder (17) on top of the lower bearing (16). Center the lower thrust bearing (18) on the lower bearing (16).
3. Carefully lower plug (2) into body until it enters the thrust bearing (18) and lower shaft bearing (16). Rotate the plug until it is nearly closed.
4. Install upper thrust bearing (7). Lubricate and install the upper grit excluder (8) and upper shaft bearing (9).
5. Lubricate and install the cover O-ring (5) and carefully lower the bonnet/cover (3) over the plug shaft so the marks are aligned.
6. Install cover bolts (4) and tighten in an alternating manner.
7. Clean the packing box and blow out any debris
8. Lubricate and install the packing set's bottom (male) adaptor ring over the shaft.
9. Lubricate and install the V-rings with the point of the "V" pointing toward the actuator (see page 2).
10. Lubricate and install the top (female) adaptor ring.
11. Place packing gland (11) over plug shaft and push packing (8) into the packing box until it is firmly seated.
12. Install gland nuts (12), tighten until they just touch the gland (11) and then tighten one more full turn.
13. Align and install actuator.
14. Close valve and (reinstall in line) and introduce pressure. Check for leaks. If a leak from the shaft packing is noticed, evenly tighten the gland bolts (12) just until the leak stops. Excess compression will increase operating torque and shorten the packing life.

REPLACEMENT PARTS

Genuine replacement parts are available from your local VAG/GA Industries representative or from the factory:

VAG USA, LLC
 234 Clay Avenue
 Mars, PA 16046 USA
 Telephone: 724-776-1020
 Fax: 724-776-1254
 E-mail: quotes-ga@vag-usa.com

Please have the nameplate data available when ordering parts. Identify needed part(s) by Shop Order (SO) Number, Figure Number, valve size and individual part number.

All parts ordered individually.

WARRANTY:

The Warranty for GA Industries valves is included in our Terms and Conditions which can be found here: <https://gaindustries.com/terms>

STANDARD PARTS LIST

Part No.	Part Name	Std. Material
1	Body	Ductile Iron w/Ni Seat
2	Plug	Ductile Iron/Buna-N
3	Bonnet/Cover	Ductile Iron
4	Cover Bolts	316 Stainless Steel
5	Cover O-Ring	Buna-N
6	Adapter	Ductile Iron
7	Upper Thrust Bearing	Aluminum Bronze
8	Upper Grit Excluder	Buna-N
9	Upper Shaft Bearing	316 Stainless Steel

STANDARD PARTS LIST

Part No.	Part Name	Std. Material
10.	Shaft V-Packing	Buna-N
11.	Packing Gland	Ductile Iron
12.	Gland Stud/Nut	316 Stainless Steel
13.	Bottom Cover	Ductile Iron
14.	Bottom Cover O-Ring	Buna-N
15.	Bottom Cover Bolts	316 Stainless Steel
16.	Lower Shaft Bearing	316 Stainless Steel
17.	Lower Grit Excluder	Buna-N
18.	Lower Thrust Bearing	Aluminum Bronze
19.	Pipe Plug	304 Stainless Steel

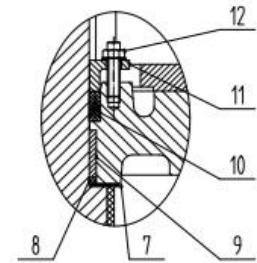
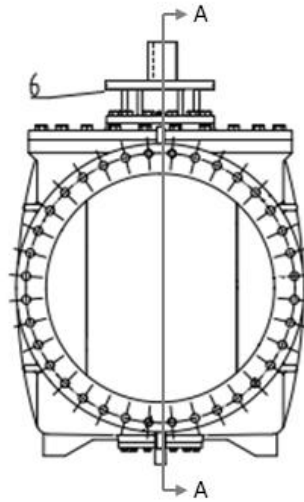
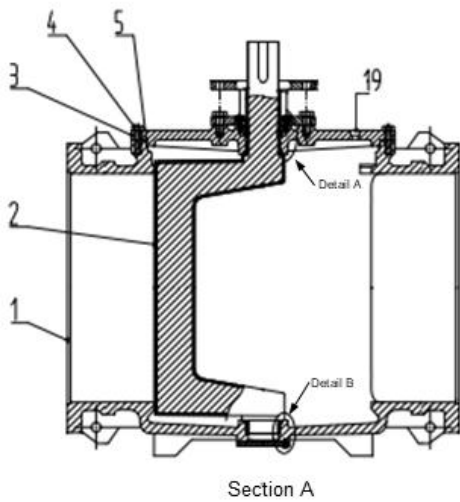

Detail A

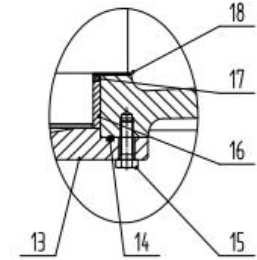

Detail B

GA Industries Figure 517R Rectangular Port Eccentric Plug Valve

Flanged Valve Shown

(MJ or flanged buried service valves have same parts but without packing access windows in cover)

