

INSTALLATION, OPERATION AND MAINTENANCE MANUAL

Figure 626-D Sewage Surge Relief Valve 2" to 3" Drawing K-1248-1 4" to 8" Drawing K-1248

TABLE OF CONTENTS

Introduction	1
Function	1
Receiving & Storage	1
Installation	1
Operation	1
Valve Construction	2
Start-Up	2
Preventive Maintenance	2
Trouble Shooting	2
Disassembly	2
Assembly	3
Replacement Parts	4
Warranty	4
Parts List	4
Assembly Drawing/Parts Location	5



234 Clay Avenue • Mars, PA 16046 USA
Telephone (724) 776-1020 • Fax (724) 776-1254
E-mail: info-ga@vag-group.com

Manual Number 626.01-IOM-062422



WARNING: Cancer and Reproductive Harm – www.Prop65Warnings.ca.gov

INSTALLATION, OPERATION and MAINTENANCE

2" to 8" Figure 626-D Sewage Surge Relief Valve

INTRODUCTION

This manual will provide the information to properly install, operate and maintain the valve to ensure a long service life. The Figure 626-D Sewage Surge Relief Valve is ruggedly constructed to provide years of trouble-free operation with minimal maintenance.

CAUTION

The valve is NOT recommended for use with toxic or highly corrosive fluids, fuels or fluids containing hazardous gases

The Shop Order (SO) Number, Figure Number, size and pressure rating are stamped on a nameplate attached to the valve. Please refer to the SO number when ordering parts.

FUNCTION

The Figure 626-D Sewage Surge Relief Valve is used to protect systems against damaging surges resulting from a sudden stoppage of flow. The valve is normally closed and opens when the inlet pressure increases to a pre-set pressure to discharge excess pressure out of the system. The valve opens as far and stays open for as long as needed to limit the pressure rise. It slowly closes as the pressure subsides below the opening pressure. The valve is designed to accommodate solids and other matter that may be present in sewage systems without clogging.

RECEIVING AND STORAGE

Inspect the valve upon receipt for damage during shipment. Carefully unload all valves to the ground without dropping.

The valves should remain in a clean, dry, and weather protected area until installed.

INSTALLATION

The Figure 626-D is a wye-body valve with in-line ANSI Class 125 flanged connections. The standard valve is intended to be installed in a horizontal pipe.

Consult the drawings of record to verify the configuration supplied and installed.

These valves are heavy, and awkward to handle, ensure proper handling techniques are employed.

Handle heavy valves using slings around the valve body and/or by the lifting eyes – **DO NOT LIFT THROUGH THE YOKE.**

Prior to installation ensure all debris, packing material or other foreign material has been removed from both ports.

Install the valve in the proper flow direction. The discharge piping connected to the outlet of the valve must be unobstructed and open to atmosphere.

If installed outdoors, below ground in a vault or in an unheated area, adequate freeze protection must be provided.

An adequate isolating valve should be installed between the valve and the pipeline or system to facilitate maintenance.

The valve is not designed to support adjacent equipment, piping loads should not be imposed on the valve and large valves should be properly supported. Ensure mating flanges are square and parallel to the valve flanges before tightening flange bolts.

Flat-faced flanged valves should be mated with flat-faced flanges and full-face gaskets. If ring gaskets are used the bolt material shall be ASTM A307 Grade B (or equivalent). Higher strength bolting should only be used with full-face gaskets.

Lubricate the bolts or studs and insert around flange. Lightly tighten bolts until gaps are eliminated. Torque bolts in an alternating pattern in graduated steps. If leakage occurs wait 24 hours and re-torque the bolts but do not compress the gasket more than 50% or exceed bolt maximum torque rating.

OPERATION

The Figure 626-D surge relief valve is held closed by the compression of springs. When the force of the system pressure acting on the face of the valve disc exceeds the spring force, the valve will lift off its seat permitting a discharge of fluid from the system. The valve will open as far as needed to discharge fluid at the rate necessary to prevent a further rise in pressure.

As the valve opens it freely draws oil from the reservoir into the piston chamber.

As the pressure subsides the spring force will push the valve closed, forcing oil back into the reservoir through a needle valve that controls the speed at which the valve closes.

VALVE CONSTRUCTION

The standard Figure 626-D surge relief valve has a cast iron body and cover, stainless steel body seat, stainless steel disc stem, resilient disc seat and alloy steel compression springs housed in a fabricated steel spring chambers.

The valve incorporates a self-contained hydraulic dashpot to control the speed at which the valve closes during pressure subsidence.

Refer to the List of Materials submitted for the order if non-standard materials were provided.

Refer to Page 5 for details of construction and parts location.

START-UP

The valve generally does not require any calibration or adjustment prior to start-up. The pressure at which the valve opens is set at the factory per the Engineer's specification and indicated on a tag wired to the valve. This pressure is typically 10 to 15% higher than the highest pressure that would be present at the valve's inlet.

The valve is shipped from the factory with the oil reservoir full of oil and a pipe plug in the fill port to prevent spillage during transit and installation.

IMPORTANT: Prior to start-up remove the pipe plug, check to make sure reservoir is $\frac{3}{4}$ " full and replace with the blue plastic vented plug that is wired to the reservoir.

If additional oil is needed, use AW32 Hydraulic Fluid.

The closing speed needle valve (23) should be initially opened $\frac{1}{4}$ turn.

Since the relief valve's opening pressure is always higher than the "normal" pressure, an abnormally high pressure is needed to test the valve's operation.

This may be accomplished by throttling valve but most of the time the pumping system is started then shut down and the reaction of the relief valve is noted.

If necessary, the pressure at which the valve starts to open can be field adjusted by simultaneously turning both adjusting nuts equally. Turn both nuts counterclockwise to lower the opening pressure. Turn both nuts clockwise to raise the opening pressure but do not exceed the maximum set pressure for the installed springs. If a higher opening pressure than

the springs allow is required, consult the factory for replacement springs.

Small adjustments to the closing speed may be made if needed. Loosen lock nut on closing speed control valve and turn screw clockwise to slow closing speed, counterclockwise to increase closing speed.

CAUTION: Do not completely close the needle valve as this will prevent the relief valve from closing once it has opened.

PREVENTIVE MAINTENANCE

Figure 626-D sewage surge relief valves require no routine lubrication, adjustment, or preventive maintenance.

A monthly inspection should be performed for the first 6 months of operation to ensure there is no external fluid leakage or audible evidence of water leaking through the closed valve.

Thereafter, a quarterly visual inspection should be performed.

TROUBLESHOOTING

- Valve Fails to Open at Desired Pressure
 - Set pressure too high – adjust springs
 - Inlet isolating valve closed – open valve
- Valve Fails to Close
 - Set pressure too low – adjust springs
 - Closing speed valve closed – adjust $\frac{1}{4}$ turn open
 - Closing speed hydraulic tubing kinked or clogged – repair/replace/clean tubing
- Leakage Through Valve When Closed
 - Debris lodged under seat – inspect/clear
 - Damaged disc seat – inspect/replace
- Valve Closes Erratically
 - Low or no oil in reservoir – fill $\frac{3}{4}$ full
 - Air in hydraulic line/dashpot chamber- bleed air
- Leakage from Weep Hole in Cover
 - Worn stem seals (19) - Replace

WARNING

Removing the valve from the line or disassembling the valve while there is pressure in the valve body may result in injury or damage to the valve

WARNING

Follow all applicable safety regulations and codes and read and understand all instructions before undertaking disassembly.

DISASSEMBLY

Figure 626-D surge relief valves can be serviced while the body remains connected to the pipeline. A skilled technician should perform all work. No special tools are required but due to the weight of large size valve's components overhead lifting capability is beneficial.

First ensure there is no pressure within the valve and operating equipment is tagged and locked out. Refer to Pages 4 and 5 for parts identification and location.

Ensure all necessary replacement parts are on hand before commencing service. Disassemble only as far as needed to inspect/replace worn parts.

1. Loosen a fitting and drain the oil from the reservoir into a clean container for re-use after re-assembly. Note position of closing speed control valve. Remove the tubing between the valve cover and reservoir. Remove the reservoir mounting bolts (42) and the reservoir (24).
2. Mark the position of both spring adjusting washer pins (33) so the springs can be reset to their original position upon reassembly.
3. Turn each spring adjusting nuts counterclockwise until all tension is removed and while supporting the spring chamber pull the spring adjusting screw assembly (30) through the spring retainer cap (35). When free, carefully lower the spring chamber.
4. If not dismantling the spring chambers to remove the springs and/or spring adjusting washers, skip to step 7.
5. To remove the springs, remove the spring chamber assemblies from the valve by removing the clevis retaining rings (38) and clevis pins (36). Remove the end caps (35) and lift out the springs (17).
6. To remove the spring adjusting washer (32), first grasp the spring adjusting washer pin (33) and pull out.
7. Lift off the spring yoke (5) and piston rod (14).
8. Mark the cover (2) and body (1) to ensure proper alignment during re-assembly, remove the cover bolts (18) and remove the cover from the body.
 - a. For 3" and smaller valves, all remaining components except the seat (19) should come out with the cover.
 - b. For 4" to 8" valves, the disc stem and disc assembly may also remain in the valve as the cover assembly is being removed. In that case, the piston (3) will be likely pushed out of the cylinder (16). Remove it from the disc stem (15) and continue removing the cover.
9. Move the cover assembly to a convenient work area and support on blocks so the disc stem is vertical to facilitate further disassembly.
10. If the piston (3) had not been exposed while the cover was removed, push on the disc (9) to expose the piston (3) and remove it.
11. If the disc stem and disc assembly did not remain in the valve when the cover was removed, pull it from the cover.

12. Remove the gland (8), lantern ring (7, in 4" to 8" only), gland packing (6) and bushing (27) from the cover.
13. Remove the seat ring follower screws (22), seat ring follower (21) and seat ring (20) from the disc (9).
14. To remove rod wiper (41) in sizes 4" to 8" valves, remove the rod wiper retainer screws (41B) and rod wiper retainer (41A).
15. Inspect all parts for wear and damage. Replace all seals and any worn and/or damaged parts.

ASSEMBLY

- 1a. Clean and polish all machined bearing and sealing surfaces. Remove burrs and sharp edges. Apply a light coat of lubricant on sealing surfaces to assist in the assembly.
- 2a. Install new seat ring (20) on disc (9), replace follower (21) and install seat ring follower screws (22). Tighten but do not distort follower ring.
- 3a. Lubricate and install the bushing seal (28) on the bushing (27) and install in the cover (2).
- 4a. Install lantern ring (7) in cover (4" to 8" only)
- 5a. Lubricate and install gland packing (6) and gland seal (10) in gland and install in cover.
- 6a. Lubricate and install rod wiper (41). Install retainer (41A) and screws (41B) (4"-8" only).
- 7a. Lubricate and install disc stem seal (13) on disc stem (15). Install disc stem/disc assembly through bottom of cover being careful not to damage rod wiper (41).
- 8a. Lubricate and install cover seal (11) on cover (2). Grasp top of disc stem (15) to prevent it from dropping while carefully installing cover (2) in body (1) making sure cover seal (11) is not damaged.
- 9a. Align cover with mark, install cover bolts (18) and tighten.
- 10a. Lubricate and install piston rod seal (12)
- 11a. Lubricate and install piston seals (4) on piston. Remove piston vent plug (29). Install piston (3) into cylinder (16) until firmly seated on shoulder of disc stem (15). Align piston vent plug with hydraulic tubing connection in cylinder (16).
- 12a. Place piston rod (14) on top of disc stem (15) and spring yoke (5) on piston rod (14).
- 14a. Re-assemble spring chambers and re-connect to valve body with clevis pins (36) and retaining rings (38) and/or align spring chambers with holes in spring yoke (5).
- 15a. Place adjusting screw washer (31) onto both adjusting screw assemblies (30), install through spring yoke (5) and end caps (35) and thread into spring adjusting washers (32).
- 16a. Simultaneously turn each adjusting screw nut clockwise until spring adjusting washer pins (33) are at original position.

- 17a. Install reservoir (24) and re-connect control piping. Threaded connections should be sealed with oil-compatible pipe sealant, not Teflon tape. Open speed control valve fully and slowly add oil to reservoir until it flows from vent port in piston. Apply pipe sealant to vent plug (29) and install in piston. Continue to fill reservoir until it is ¾ full. If additional oil is needed, use non-foaming AW32 hydraulic fluid. Re-install blue plastic air vent plug (37)
- 18a. Reset closing speed control to original position and tighten locknut.
- 19a. Slowly open inlet valve to introduce pressure and check for leaks.

REPLACEMENT PARTS

Genuine replacement parts are available from your local VAG/GA Industries representative or from the factory:

VAG USA, LLC
 234 Clay Avenue
 Mars, PA 16046 USA
 Telephone: 724-776-1020
 Fax: 724-776-1254
 E-mail: quotes-ga@vag-usa.com

Please have the nameplate data available when ordering parts. Identify needed part(s) by Shop Order (SO) Number, Figure Number, valve size and individual part number.

REPAIR KITS

Soft Goods Kit includes Items 4, 6, 10, 11, 12, 13, 20, 28 and 41

Size	Kit Number	Part Number
2" to 3"	K3	2-80-25000-431
4"	K4	2-80-25000-432
6"	K6	2-80-25000-433
8"	K8	2-80-25000-434

All other parts ordered individually.

WARRANTY:

The Warranty for GA Industries valves is included in our Terms and Conditions which can be found here: <https://gaindustries.com/terms>

PARTS LIST

Part No.	Part Name	Std. Material
1	Body	Cast Iron
	Cover	Cast Iron
3	Piston (2"- 4")	Stainless Steel
	Piston (6"-8")	Bronze
4	Piston Seal	Buna-N Rubber
5	Spring Yoke	Steel
6	Gland Packing	Buna-N Rubber
7	Lantern Ring (4"- 8" only)	Bronze
8	Gland	Stainless Steel
9	Disc	Ductile Iron
10	Gland Seal	Buna-N Rubber
11	Cover Seal	Buna-N Rubber
12	Piston Rod Seal	Buna-N Rubber
13	Disc Stem Seal	Buna-N Rubber
14	Piston Rod	Steel
15	Disc Stem	Stainless Steel
16	Cylinder	Bronze
17	Spring	Alloy Steel
18	Cover Bolt	Steel
19	Seat	Stainless Steel
20	Seat Ring	Thiokol
21	Seat Ring Follower	Stainless Steel
22	Seat Ring Follower Screws	Stainless Steel
23	Flow Control Valve	Commercial
24	Oil Reservoir	Steel
27	Bushing	Bronze
28	Bushing Seal	Buna-N Rubber
29	Piston Vent Plug	Bronze
30	Spring Adjusting Screw	Steel
31	Adjusting Screw Washer	Steel
32	Spring Adjusting Washer	Brass or SS
33	Spring Adjusting Washer Pin	Steel
34	Spring Chamber	Steel
35	Spring Retainer Cap	Bronze
36	Clevis Pin	Stainless Steel
36A	Clevis Pin Link (4"-8" only)	Steel
37	Air Vent Plug	Plastic
38	Clevis Pin Retaining Ring	Steel
39	Disc Stem Locking Screw	Stainless Steel
40	Disc Stem Locking Washer	Stainless Steel
41	Rod Wiper	Buna-N Rubber
41A	Wiper Retainer	Brass
41B	Wiper Retainer Screws	Stainless Steel

NOTE: Parts 41A and 41B not used in 4" to 8" size valves

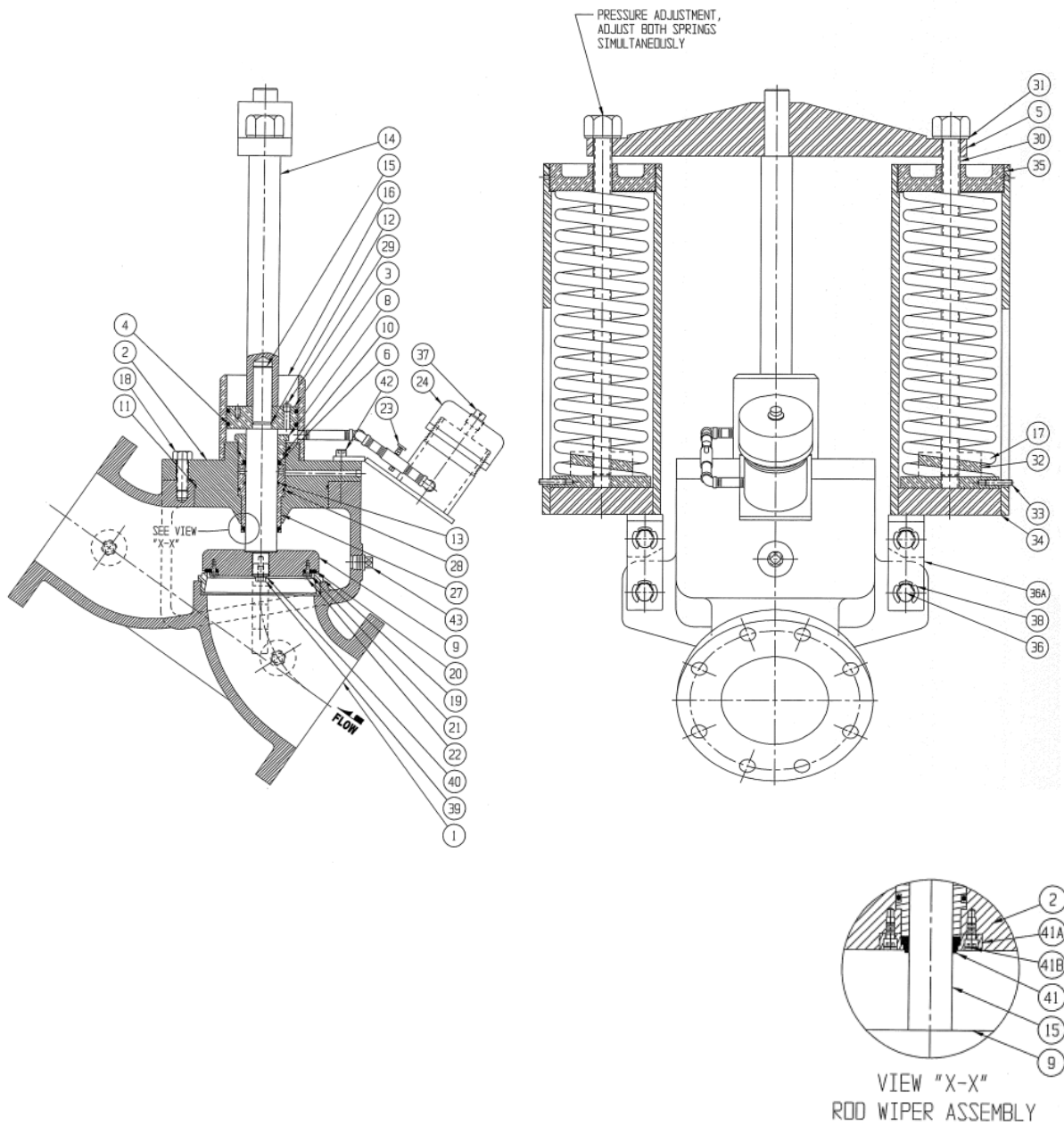

Figure 626-D Sewage Surge Relief Valve