

Figures 7125-D, 7125-U Tilting Disc Check Valve

Description

GA Industries Tilting Disc Check Valve features a streamlined design and full flow area for lower head loss than conventional swing check valves. Its energy efficient operation is combined with a short 40-degree disc stroke that provides quick closing valve to minimize hammer.

The valve employs offset seating technology to smoothly lift the disc off of the seat during opening and into the seat during closing without binding or sticking.

The offset also design divides the disc so hydraulic forces acting on the upper third of the disc counteract the lower two thirds for an inherent cushioning effect.

Product Features

- Full port waterway with streamlined flow path
- Stable airfoil shaped disc
- No packing glands or external weights or springs
- Upstream and downstream inspection ports

Standard Materials

- Class 125 Body Cast Iron, ASTM A126 Class B
- Class 250 Body Ductile Iron, ASTM A536 Grade 65-45-12
- Disc (6" to 14") Lead Free Bronze, C95400
- Disc (16" to 36") Ductile Iron, ASTM A536 Grade 65-45-12 Ductile Iron,
- Body Seat Ring Lead Free Bronze, C95400
- Disc Seat Ring Lead Free Bronze, C95400
- Pivot Pins Stainless Steel, Type 303
- Pivot Bushings Lead Free Bronze, C95400
- External Fasteners A307 Steel, Zinc Plated
- Coating Internal and external Carboguard 891 NSF-61 certified 2-part epoxy



Options/Accessories

- Option PI Visual Position Indicator
- Option 1D With Single Honeywell Micro Switch NEMA 1, 2, 4, 6, 12 & 13 DPDT Limit Switch (Includes Visual Position Indicator)
- Option 2D With Dual Honeywell Micro Switch NEMA 1, 2, 4, 6, 12 & 13 DPDT Limit Switches (Includes Visual Position Indicator)

Ordering Data

- Figure Number (7125-D, 7125-U)
- Size
- Options and/or Accessories

Other Versions

- With Bottom Buffer – See Data Sheet 7125B.01
- With Top Mounted Hydraulic Dashpot – See Data Sheet 7125T.01

Non-Shock Working Water Pressure at up to 150F (66C)

Figure Number	7125-D	7125-U
Size	6" to 36"	6" to 36"
Flange	ANSI B16.1 Class 125	ANSI B16.1 Class 250
Max Working Pressure	150 PSI	250 PSI
Hydro Test	225 PSI	375 PSI

Data Sheet 7125.01D

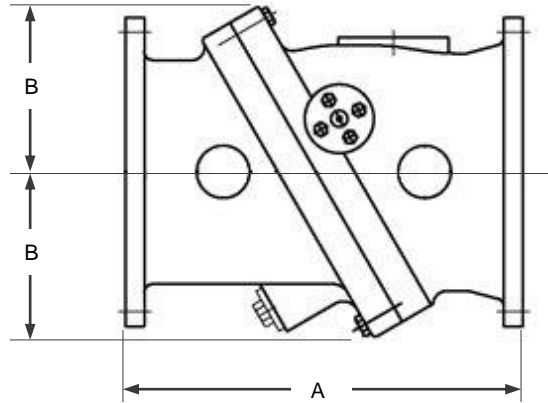
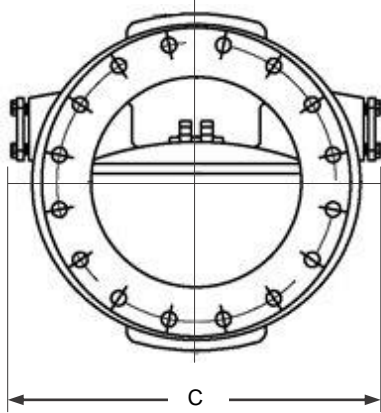

Installation Dimensions

SIZE	6"	8"	10"	12"	14"	16"	18"	20"	24"	30"	36"	
A	15½	17½	24½	24	31	30	33	32	38	52	59½	
B	5½	7¼	8¼	10	10¾	12⅝	13⅝	14¼	16½	22⅝	25	
C	14	19	19½	25	26	28½	30½	34	36½	48	53	
WGT	CL125	200	300	460	650	900	1,150	1,550	1,810	2,680	5,000	7,700
	CL250	245	355	550	760	1,055	1,365	1,880	2,180	3,265	5,725	8,410

Dimensions in inches, weight in pounds and are approximate. Request certified drawings if critical.
Dimension A same for Class 125 and 250. Class 250 supplied flat face.

