

Figures 7125B-D, 7125B-U

Tilting Disc Check Valve w/Bottom Buffer

Description

GA Industries Tilting Disc Check Valve features a streamlined design and full flow area for lower head loss than conventional swing check valves. Its energy efficient operation is combined with a short 40-degree disc stroke that provides quick closing to minimize hammer.

The valve employs offset seating technology to smoothly lift the disc off of the seat during opening and into the seat during closing without binding or sticking.

If flow reversal occurs, the offset disc design divides the disc so that hydraulic forces acting on the upper third of the disc counteract the forces acting on the lower two thirds for an inherent cushioning effect.

The bottom buffer is a hydraulic dashpot that further minimizes hammer by decelerating the final 10% of the disc's closure in situations where rapid flow reversal occurs, such as multiple pumps and/or short pipes.

Product Features

- Full port waterway with streamlined flow path
- Stable airfoil shaped disc
- Lead-free bronze, drip tight seating
- Bottom buffer with adjustable final closing speed control

Standard Materials

- Class 125 Body Cast Iron, ASTM A126 Class B
- Class 250 Body Ductile Iron, ASTM A536 Grade 65-45-12
- Disc (6" to 14") Lead Free Bronze, C95400
- Disc (16" to 36") Ductile Iron, ASTM A536 Grade 65-45-12 Ductile Iron,
- Body Seat Ring Lead Free Bronze, C95400
- Disc Seat Ring Lead Free Bronze, C95400
- Pivot Pins Stainless Steel, Type 303
- Pivot Bushings Lead Free Bronze, C95400
- Bottom Buffer Steel and Stainless Steel
- External Fasteners A307 Steel, Zinc Plated
- Coating Internal and external Carboguard 891 NSF-61 certified 2-part epoxy



Data Sheet 7125B.01D

Options/Accessories

- Option PI Visual Position Indicator
- Option 1D With Single Honeywell Micro Switch NEMA 1, 2, 4, 6, 12 & 13 DPDT Limit Switch (Includes Visual Position Indicator)
- Option 2D With Dual Honeywell Micro Switch NEMA 1, 2, 4, 6, 12 & 13 DPDT Limit Switches (Includes Visual Position Indicator)

Ordering Data

- Figure Number (7125B-D, 7125B-U)
- Size
- Options and/or Accessories

Other Versions

- Plain – See Data Sheet 7125.01
- With Top Mounted Dashpot – See Data Sheet 7125T.01

Non-Shock Working Water Pressure at up to 150F (66C)

Figure Number	7125B-D	7125B-U
Size	6" to 36"	6" to 36"
Flange	ANSI B16.1 Class 125	ANSI B16.1 Class 250
Max Working Pressure	150 PSI	250 PSI
Hydro Test	225 PSI	375 PSI

Data Sheet 7125B.01D

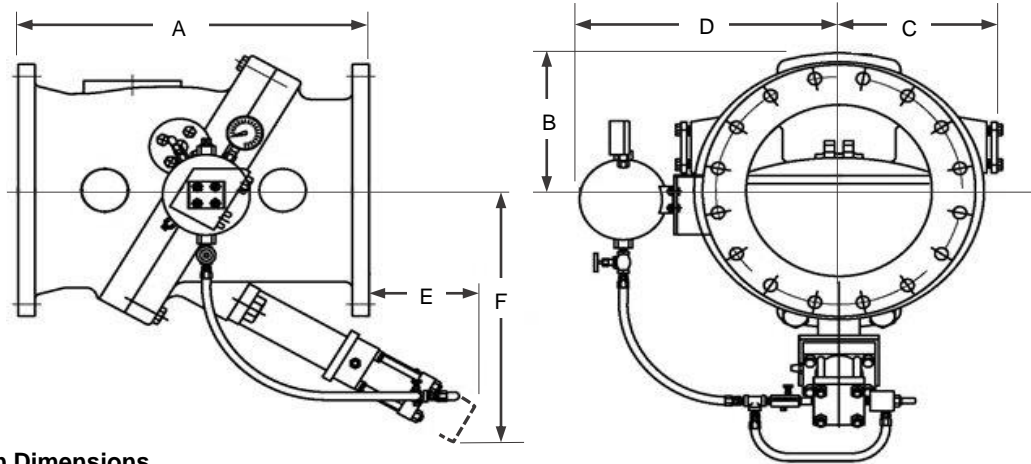

Installation Dimensions

SIZE	6"	8"	10"	12"	14"	16"	18"	20"	24"	30"	36"	
A	15½	17½	24½	24	31	30	33	32	38	52	59½	
B	5½	7¼	8¼	10	10¾	12⅝	13⅞	14¼	16½	22⅞	25	
C	7	9½	9¼	12½	13	14¼	15¼	17	18¼	24	26½	
D	13¼	13¼	15	16	18	20	21½	23	25	35	34	
E	4¾	6⅝	8	7¾	4½	10¼	8	8½	6½	7	7½	
F	12½	15½	18¼	19⅞	20½	24¾	25½	26½	29½	35	41	
WGT	CL125	225	325	485	690	940	1,210	1,615	1,875	2,750	5,150	7,900
	CL250	270	380	575	800	1,095	1,425	1,945	2,245	3,335	5,875	8,610

Dimensions in inches, weight in pounds and are approximate. Request certified drawings if critical.
Dimension A same for Class 125 and 250. Class 250 supplied flat face.
Dimensions E and F allow for bottom buffer removal

