

Figures 920, 920H

Compound Lever Air Release Valve

Description

GA Industries Figures 920 and 920H are used to minimize the build up of air in water pipes and systems by automatically and efficiently releasing air that has collected in the valve while under pressure and operational. Typically installed at high points where air naturally collects, the valve opens when sufficient air has accumulated in the valve and closes tightly after the air has been released.

Figures 920 and 920H are also installed on the top of the volute of split case pumps, on pressure filters and any place where it's necessary to automatically release air for efficient system operation.

Product Features

- Compound lever design allows larger venting orifice and higher venting rate
- Rugged iron body and cover
- Corrosion resistant Type 316 stainless steel float and internal mechanism
- Tight sealing and easily replaceable rubber seat

Standard Materials

- Body & Cover Cast Iron, ASTM A126 Class B
- Float Stainless Steel, Type 316
- Internal Linkage Stainless Steel, Type 316
- Replaceable Seat Buna-N
- External Fasteners Steel, A307, Zinc Plated
- Coating Internal and External NSF-61 Certified Epoxy



Approvals & Certifications

- Complies with AWWA Standard C512
- NSF-61 Certified for Contact with Drinking Water
- NSF-372 Certified Lead Free (Max 0.25% Lead Content by Weighted Average)

Options/Accessories

- Option BA Build America/Buy America (BABA) and American Iron and Steel (AIS) Compliant
- Option IV Inlet Isolating Valve – lever operated bronze ball valve
- Option SE 316 Stainless Steel External Fasteners
- Option US American Iron & Steel (AIS) Compliant
- Option VC: Vacuum Check – prevents air re-entry if internal pressure falls below atmospheric

Ordering Data

- Figure Number (920 or 920H)
- Size
- Options/Accessories

Non-Shock Working Water Pressure at up to 150F (66C)		
Figure No.	920	920H
Connections	NPT	NPT
Inlet Size	1" or 2"	1" or 2"
Outlet Size	½"	½"
Orifice Diameter	0.188"	0.125"
Working Pressure	10-150 PSI	10-300 PSI
Pressure Rating	300 PSI	300 PSI
Hydro Test	450 PSI	450 PSI
Weight	24 lbs.	24 lbs.

Data Sheet 920.01D

Pressure At Valve Inlet	Air Venting Rate, Standard Cubic Feet/Min (SCFM)	
	Figure 920	Figure 920H
10 PSI	8.7	3.9
15 PSI	10.6	4.7
25 PSI	14.1	6.3
50 PSI	23.1	10.3
75 PSI	32.0	14.2
100 PSI	40.9	18.2
150 PSI	58.7	26.1
200 PSI		34.0
250 PSI		41.9
300 PSI		49.8

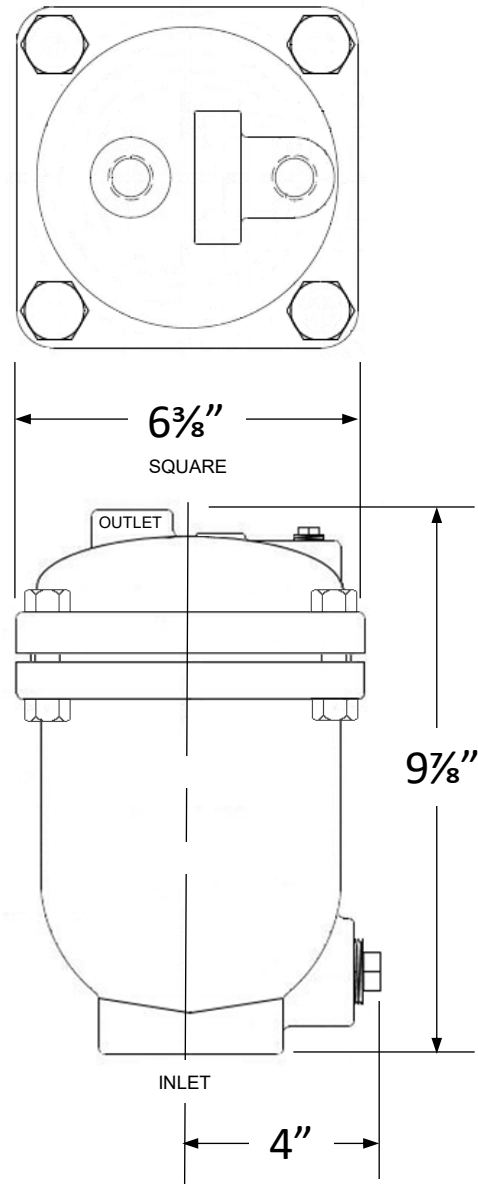

INLET ISOLATING
LEAD FREE BRONZE
BALL VALVE

VACUUM CHECK

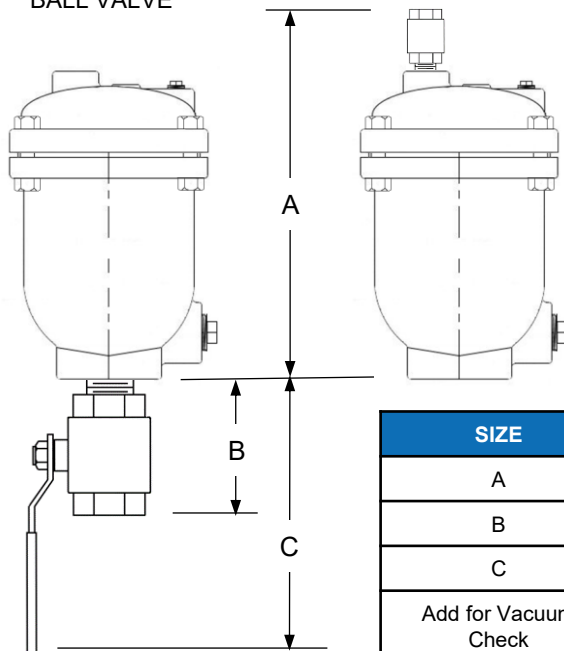

SIZE	1"	2"
A	13"	13"
B	4"	5"
C	8"	10½"
Add for Vacuum Check	1 lb.	1 lb.
Add for Inlet Ball Valve	2 lbs.	8 lbs.

All dimensions and weights are approximate. If critical request certified drawings