

Figures 925, 925F, 925L, 925LF 4" Class 125 Flanged Sewage/Wastewater Air Release Valve

Description

GA Industries Figures 925 and 925L automatically and efficiently release air and gas that have collected in the valve while under pressure and operational. Typically installed at high points where air and gas naturally collect, the valve opens when sufficient air and gas has accumulated in the valve and closes tightly after the air has been released.

The valves employ a specially designed elongated body to maintain the solids bearing fluid far enough below the internal mechanism to minimize clogging and maintenance.

Figures 925F and 925LF include optional "back flushing attachments" to facilitate cleaning sludge and debris from the valve.

Product Features

- Rugged iron body and cover
- Compound lever design allows larger venting orifice and higher venting rate
- Corrosion resistant Type 316 stainless steel float and internal mechanism
- Tight sealing and easily replaceable rubber seat
- 2" NPT plugged port to facilitate removal of large debris

Standard Materials

- Body & Cover Cast Iron, ASTM A126 Class B
- Float Stainless Steel, Type 316
- Internal Linkage Stainless Steel, Type 316
- Replaceable Seat Buna-N
- External Fasteners Steel, A307, Zinc Plated
- Coating Internal and External NSF-61 Certified Epoxy

See Data Sheet 925SS.01 for Durovent™ all 316SS construction version

Non-Shock Working Water Pressure at up to 150F (66C)		
Figure Nos.	925L, 925LF	925, 925F
Pipeline Connection	4" ANSI Class 125 Flange	
Outlet	½" NPT	½" NPT
Orifice Diameter	0.313"	0.188"
Working Pressure	10-75 PSI	10-150 PSI
Pressure Rating	200 PSI	200 PSI
Hydro Test	300 PSI	300 PSI
Weight	75 lbs.	75 lbs.



Approvals

- Complies with AWWA Standard C512
- NSF-61 Certified for Contact with Drinking Water
- NSF-372 Certified Lead Free (Max 0.25% Lead Content by Weighted Average)

Options/Accessories

- Option BA: Complies with American Iron and Steel (AIS) and Build America Buy America (BABA) requirements
- Option FA: Backflush Attachments – facilitates flushing debris and sludge from valve, includes inlet isolating butterfly valve, flushing and blow off bronze ball valves, quick connect couplings and 5 ft. rubber hose
- Option IV: Inlet Isolating Valve – lever operated AWWA flanged butterfly valve (included with backflush attachments)
- Option SE: 316 Stainless Steel external fasteners
- Option US: Complies with American Iron and Steel America (AIS) requirements
- Option VC: Vacuum Check – prevents air re-entry if internal pressure falls below atmospheric

Ordering Data

- Figure Number (925, 925F, 925L or 925LF)
- 4" Size
- Options/Accessories

Data Sheet 925.02A

Pressure At Valve Inlet	Air Venting Rate, Standard Cubic Feet/Min (SCFM)	
	Figure 925L	Figure 925
10 PSI	24.3	8.7
15 PSI	29.4	10.6
25 PSI	39.3	14.1
50 PSI	64.0	23.1
75 PSI	88.8	32.0
100 PSI		40.9
150 PSI		58.7

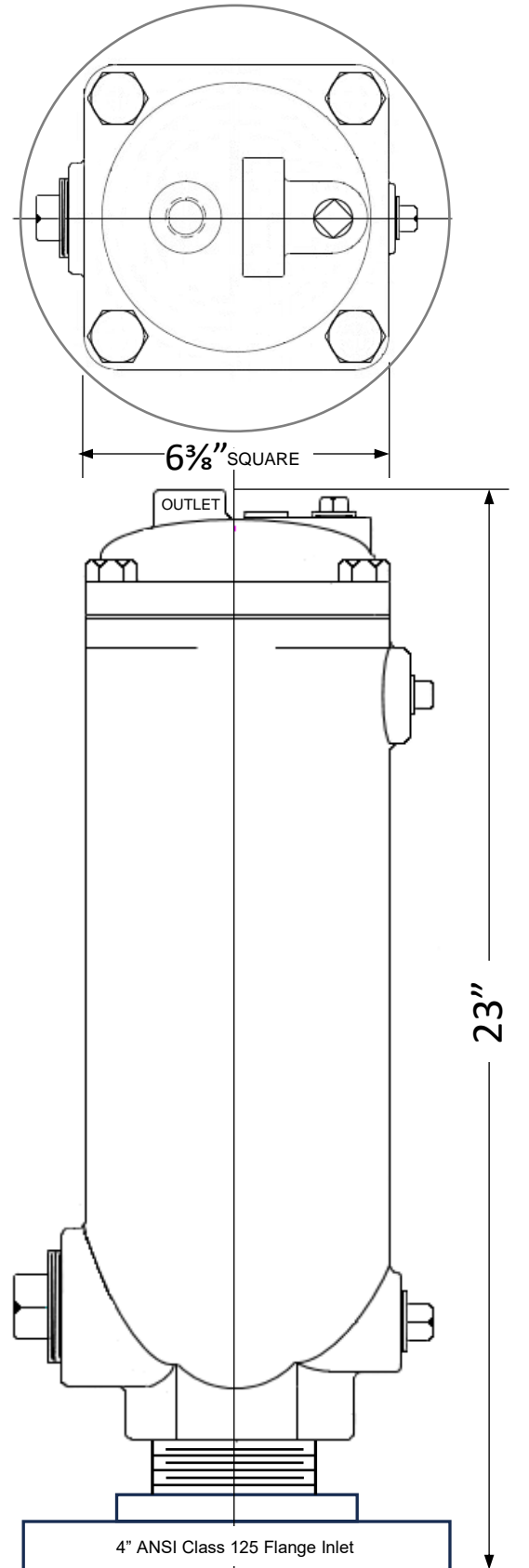

With VACUUM CHECK
and/or INLET ISOLATING
BUTTERFLY VALVE

With BACKFLUSH
ATTACHMENTS

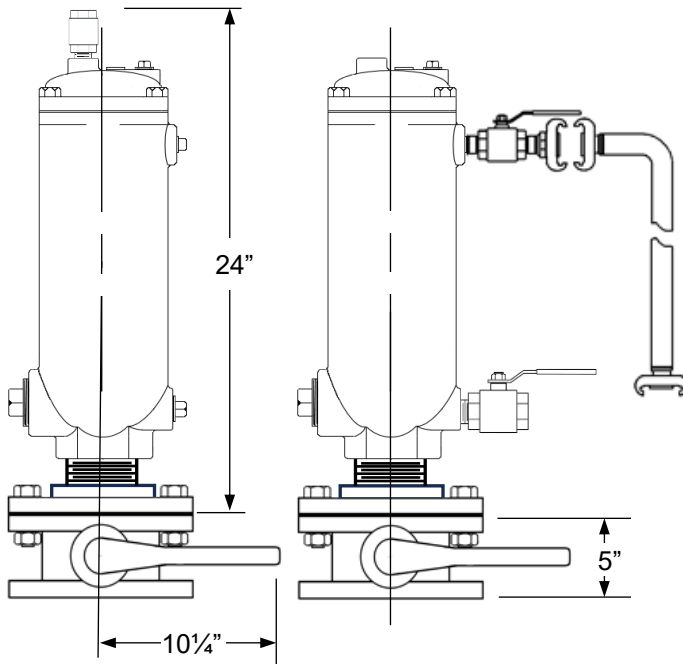

CONNECTION SIZE	4"
Add for Vacuum Check	1 lb.
Add for Inlet Butterfly Valve	45 lbs.
Add for Backflush Attachments	55 lbs.

All dimensions and weights are approximate. If critical request certified drawings