

Figures 925SS, 925SSF, 925SSL, 925SSLF Durovent® All 316 Stainless Steel Sewage/Wastewater Air Release Valve

Description

GA Industries Figures 925SS and 925SSL automatically and efficiently release air and gas that have collected in the valve while under pressure and operational. Typically installed at high points where air and gas naturally collect, the valve opens when sufficient air and gas has accumulated in the valve and closes tightly after the air has been released.

Whether due to the fluid itself or ambient conditions, Durovent® Wastewater Air Release Valves provide the ultimate in corrosion resistance since the body, cover, float, internal linkage, external fasteners and pipe plugs are all made from Type 316 stainless steel. The valves also employ a specially designed elongated body to maintain the solids bearing fluid far enough below the internal mechanism to minimize clogging and maintenance.

Figures 925SSF and 925SSLF include optional “back flushing attachments” to facilitate cleaning sludge and debris from the valve



Product Features

- Rugged cast 316 stainless steel body and cover
- Compound lever design allows larger venting orifice and higher venting rate
- Corrosion resistant Type 316 stainless steel float and internal mechanism – no plastic components
- Tight sealing and easily replaceable rubber seat
- 2” NPT plugged port to facilitate removal of large debris

Standard Materials

- Body & Cover Stainless Steel, Type 316
- Float Stainless Steel, Type 316
- Internal Linkage Stainless Steel, Type 316
- Replaceable Seat Buna-N
- External Fasteners Stainless Steel, Type 316
- Pipe Plugs Stainless Steel, Type 316

Approvals & Certifications

- Complies with AWWA Standard C512

Options/Accessories

- Option VC: Vacuum Check – prevents air re-entry if internal pressure falls below atmospheric
- Option IV Inlet Isolating Valve – lever operated bronze ball valve (included with backflush attachments)

Ordering Data

- Figure Number (925SS, 925SSF, 925SSL or 925SSLF)
- Size
- Options/Accessories

Non-Shock Working Water Pressure at up to 150F (66C)		
Figure Nos.	925SSL, 925SSLF	925SS, 925SSF
Connections	NPT	NPT
Inlet Size	2” or 3”	2” or 3”
Outlet Size	½”	½”
Orifice Diameter	0.313”	0.188”
Working Pressure	10-75 PSI	10-150 PSI
Pressure Rating	200 PSI	200 PSI
Hydro Test	300 PSI	300 PSI
Weight	60 lbs.	60 lbs.

Data Sheet 925SS.01C

Pressure At Valve Inlet	Air Venting Rate, Standard Cubic Feet/Min (SCFM)	
	Figure 925SSL	Figure 925SS
10 PSI	24.3	8.7
15 PSI	29.4	10.6
25 PSI	39.3	14.1
50 PSI	64.0	23.1
75 PSI	88.8	32.0
100 PSI		40.9
150 PSI		58.7

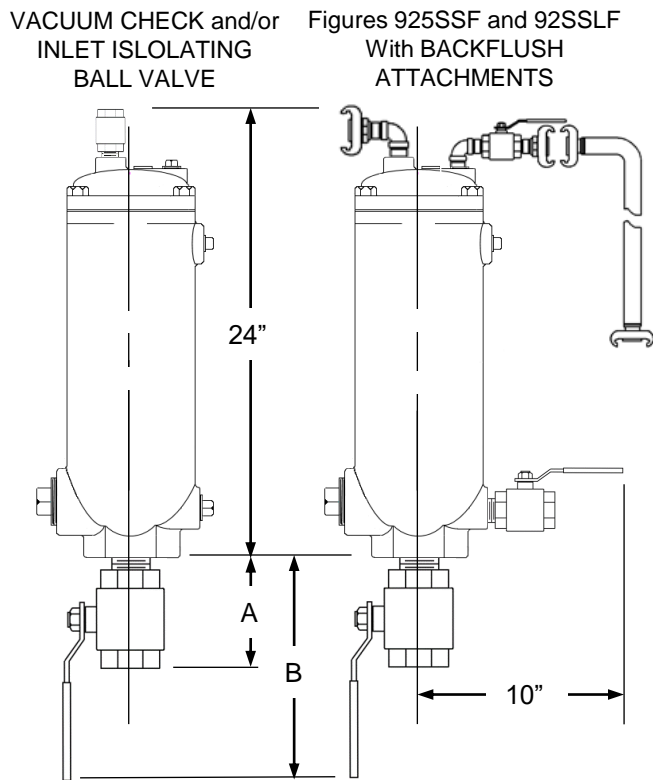
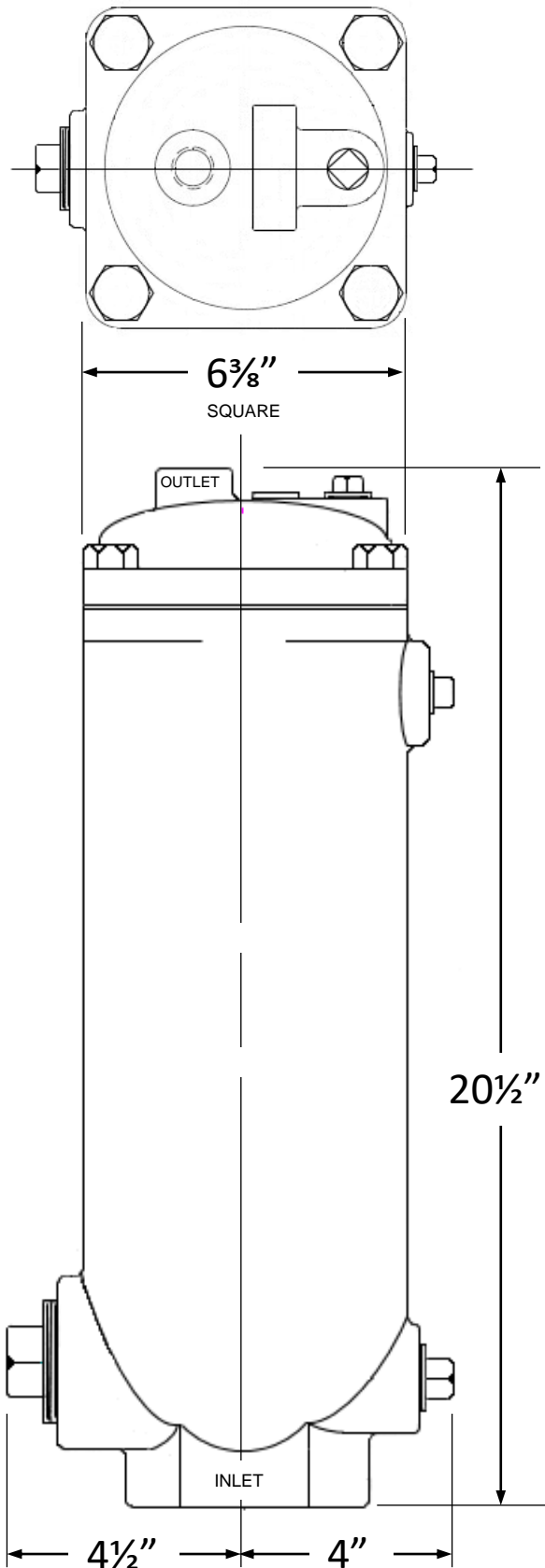

CONNECTION SIZE	2"	3"
A	5"	8"
B	8"	5"
Add for Vacuum Check	1 lb.	1 lb.
Add for Inlet Ball Valve	2 lbs.	8 lbs.
Add for Backflush Attachments	15 lbs.	21 lbs.

All dimensions and weights are approximate. If critical request certified drawings