

# INSTALLATION, OPERATION AND MAINTENANCE MANUAL

## FIGURE 929

### SHORT BODY AIR RELEASE VALVES FOR SEWAGE & WASTEWATER

#### TABLE OF CONTENTS

Introduction .....	2
Description of Operation .....	2
Receiving & Storage .....	2
Installation .....	2
Valve Construction .....	3
Preventive Maintenance .....	3
Testing/Trouble Shooting .....	3
Disassembly .....	3
Assembly .....	4
Backflushing Instructions .....	4
Order Replacement Parts .....	5
Repair Kits .....	5
Warranty .....	5
Figure 929 Drawing/Parts List .....	5



**234 Clay Avenue • Mars, PA 16046 USA**  
**Telephone (724) 776-1020 • Fax (724) 776-1254**  
**E-mail: [info-ga@vag-group.com](mailto:info-ga@vag-group.com)**



**WARNING: Cancer and Reproductive Harm – [www.Prop65Warnings.ca.gov](http://www.Prop65Warnings.ca.gov)**

# INSTALLATION, OPERATION and MAINTENANCE

## Figure 929 Short Body Sewage Air Release Valves

### INTRODUCTION

This manual will provide the information to properly install, operate and maintain the valve to ensure a long service life. The Air Release Valve is ruggedly constructed to provide years of trouble-free operation with minimal maintenance.

#### CAUTION

The valve is NOT recommended for use with toxic fluids, fuels or fluids containing hazardous gases

#### CAUTION

The valve will not function if used at a pressure higher than the maximum working pressure indicated on the nameplate.

The Shop Order (SO) Number, Figure Number, size and pressure rating are stamped on a nameplate attached to the valve. Please refer to the SO number when ordering parts.

### DESCRIPTION OF OPERATION

The Figure 929 Air Release Valve is designed to automatically vent air and sewage gas that has accumulated within the valve. These valves are usually installed at high points in the system where air tends to collect. The valve is "normally-open" as shipped and will vent air through its orifice at the top of the valve. The float rises when water enters the valve and closes the orifice. Air from the system accumulates in the valve forcing the water level down until the float drops and opens the venting orifice. As air is released the water level rises lifting the float and re-closing the valve.

This sequence occurs as often as necessary to release air that has collected in the valve.

### RECEIVING AND STORAGE

Inspect the valve upon receipt for damage during shipment. Carefully unload all valves to the ground without dropping.

The valves should remain in a clean, dry and weather protected area until installed. For long term storage (greater than 6 months) the rubber surfaces of the seat should be coated with a non-toxic lubricant such as "SuperLube" made by Synco Chemical. Do not expose the rubber parts to sunlight or ozone.

### INSTALLATION

The Figure 929 is standard with 2" or 3" NPT screwed connections. A flanged pipeline connection is provided on special order.

Consult the drawings of record to verify the configuration supplied and installed.

The valve must be installed in an upright vertical orientation, normally at a high point in the system.

If installed outdoors, below ground in a vault or in an unheated area, adequate freeze protection must be provided.

An isolating valve should be installed between the valve and the pipeline or system to facilitate maintenance (included with backflushing attachments).

Carefully screw threaded end valves onto pipe nipple using compatible thread sealant. Tighten valve using wrench flats. DO NOT OVER-TIGHTEN.

Flat-faced flanged valves should be mated with flat-faced flanges and full-face gaskets. If ring gaskets are used the bolt material shall be ASTM A307 Grade B (or equivalent). Higher strength bolting should only be used with full-face gaskets.

Lower heavy valves over the mating flange using slings or chains around the valve body. Lubricate the bolts or studs and insert around flange. Lightly tighten bolts until gaps are eliminated. Torque bolts in an alternating pattern in graduated steps. If leakage occurs

wait 24 hours and re-torque the bolts but do not compress the gasket more than 50% or exceed bolt maximum torque rating.

### VALVE CONSTRUCTION

The standard Figure 929 Sewage Air Release Valve has a cast iron body, stainless steel float and linkage mechanism and a rubber seat. Optional materials such as ductile iron body can be provided for higher working pressures. Refer to the List of Materials submitted for the order if non-standard materials were provided.

Refer to Page 5 for details of construction and parts location.

The Figure 929 has a 10 to 150 PSI working pressure range while the Figure 929L has a 10 to 75 PSI working pressure range.

The valve has an inlet connection at the bottom where the valve attaches to the system and a smaller outlet connection at the top through which air leaves the valve.

**WARNING**  
Removing the valve from the line or disassembling the valve while there is pressure in the valve body may result in injury or damage to the valve

### PREVENTIVE MAINTENANCE

Figure 929 Sewage Air Release Valves require no scheduled lubrication or adjustment.

A periodic visual inspection should be performed to ensure the outlet piping is not obstructed and to verify there is no fluid leakage.

Depending on the nature of the fluid, sewage air valves may become clogged with sediment or grease and require periodic cleaning. To facilitate such cleaning VAG/GA Industries air valves with an "F" at the end of the Figure Number (e.g., 929F, 929LF) were supplied with "backflushing attachments." Refer to the backflushing instructions on Page 4 of this manual for additional information.

### TESTING

Valve operation can be easily tested. Close the inlet isolation valve and remove or loosen the pipe plug nearest the inlet to drain the water from the valve. The float should drop as the water leaves the valve. NOTE: A manual valve can be installed in place of the pipe plug to

facilitate testing (valves are included with backflushing attachments).

Replace or tighten the pipe plug and slowly open the inlet isolating valve. After expelling air, the valve should close and seal tightly.

### TROUBLESHOOTING

- Valve Does Not Close / Fluid Leakage  
Verify debris has not collected on the seat preventing tight closure

Verify rubber orifice button and/or orifice seating surfaces are not damaged

Verify float has buoyancy

Verify linkage mechanism operates freely without binding or sticking

Verify the pressure at the valve inlet is at least 10 PSI

- Valve Does Not Open  
Verify debris in the valve is not preventing the float from freely falling when fluid is drained from valve

Verify linkage mechanism operates freely without binding or sticking

Verify the pressure at the valve inlet does not exceed the valve's maximum working pressure

### DISASSEMBLY

While small valves may be more easily serviced by removing it from the line, all valves can be serviced while the body remains connected to the pipeline. A skilled technician with proper tools should perform all work. No special tools are required.

Disassemble the valve only as far as needed to replace damaged or worn parts.

First ensure there is no pressure within the valve. Remove the cover bolts (16) and lift off cover (2) with float and linkage attached. It may be necessary to pry the cover off. Be careful not to damage or lose the O-ring (10) unless it's being replaced.

Remove the two spring pins (13) connecting the lever arm (11) and float arm (12) to the bracket (3). The float and linkage will be free from the cover.

Remove the spring pins (13) connecting the valve links (14) to the float arm (12). Remove the spring pin (13) from the pivot link (15) and the hex nut (8) and lock washer (9). Unscrew the float rod (21) from the float ball (20). It may be necessary to apply some heat to these threaded connections as they are secured with Loctite.

Remove the hex nut (8) and lock washer (9) and unscrew the orifice button (7) from the lever arm (11).

Remove the bracket screw (5) to remove the leverage bracket (3). Using a hex socket remove the orifice (4) from the cover.

Inspect all parts for wear and damage. Minor scratches and dents in the float are normal. Some floats may contain sand for added weight but if water is detected replace the float. Carefully clean the orifice of scale. Replace damaged parts.

#### REASSEMBLY

Clean all parts especially seating and sealing surfaces before reassembling valve. Worn parts should be replaced during re-assembly.

Apply Loctite<sup>®</sup> PST thread sealant to orifice (4) and thread into cover. Torque to 22 ft-lbs (maximum).

Install bracket (3), bracket screws (5) and lock washers (6) and tighten.

Thread orifice button (7) all the way into lever arm (11) and install hex nut (8) and lockwasher (9) but do not tighten. Connect the lever arm (11) and float arm (12) to the bracket (3) using two spring pins (13).

Adjust the orifice button (7) so that the end of the lever arm (11) nearest the orifice button is about 1/16" (1.6mm) farther from the cover than the opposite end when the orifice button (7) is gently resting on the orifice (4). Secure by tightening hex nut (8).

Install valve links (14) and spring pins (13) to connect the float arm (12) to the lever arm (11).

Apply Loctite 263 to one end of float rod threads and Install lock washer (9) and float rod (21) into float ball (20) and tighten. Apply Loctite 263 to the threads on the other end of float rod. Install pivot link (15), lock washer (9) and hex nut (8)

on opposite end of float rod (19) and tighten. Attach pivot link (15) to float arm (12) using spring pin (13).

Verify free movement of linkage mechanism and that the orifice button (7) presses against the orifice (4) when the float rises and pulls away when allowed to fall.

Lubricate and place O-ring (10) in cover (2) and carefully place cover (2) on body (1) ensuring o-ring is retained. Install the cover bolts (16) and tighten in an alternating pattern.

Carefully introduce pressure and check for leaks.

#### BACKFLUSHING INSTRUCTIONS

Follow all local cross-connection and safety codes and regulations!
---

To determine if a GA Industries sewage air valve needs cleaning or backflushing:

- Close the inlet isolating valve then slowly open the ½" flushing ball valve (if installed) or slowly remove the pipe plug at the top of air valve to relieve internal pressure.
- Open the 1" blow off ball valve (if installed) or remove the pipe plug near the bottom. Liquid should freely drain from the valve body. If it does not, then the valve is likely in need of cleaning or backflushing.

To clean a GA Industries sewage air release valve equipped with backflushing attachments:

- Close the inlet isolating valve and then slowly open the ½" flushing valve to relieve internal pressure.
- Open the 1" blow off valve
- Connect the ½" flushing valve to a pressurized source of clean water using the rubber hose provided with the backflushing attachments.
- Introduce flushing water until liquid runs freely from the blow off valve.
- Shut off and disconnect the supply of clean water and close the blow off and flushing valves.
- Slowly open the inlet isolating valve. The air release valve should exhaust air and then close tightly

## REPLACEMENT PARTS

Genuine replacement parts are available from your local VAG/GA Industries representative or from the factory:

VAG USA, LLC  
 234 Clay Avenue  
 Mars, PA 16046 USA  
 Telephone: 724-776-1020  
 Fax: 724-776-1254  
 E-mail: [quotes-ga@vag-group.com](mailto:quotes-ga@vag-group.com)

Please have the nameplate data available when ordering parts.

## REPAIR KITS

Soft Goods Kit A929 (Part Number 2-80-11000-010) contains Items 7, 8, 9 and 10

Linkage Kit AL929 (Part Number 2-80-11000-086) contains Items 3, 5, 6, 11, 12, 13, 14, 15 and 21

Other parts are ordered individually.

## WARRANTY

The Warranty for GA Industries valves is included in our Terms and Conditions which can be found here: <https://gaindustries.com/terms>

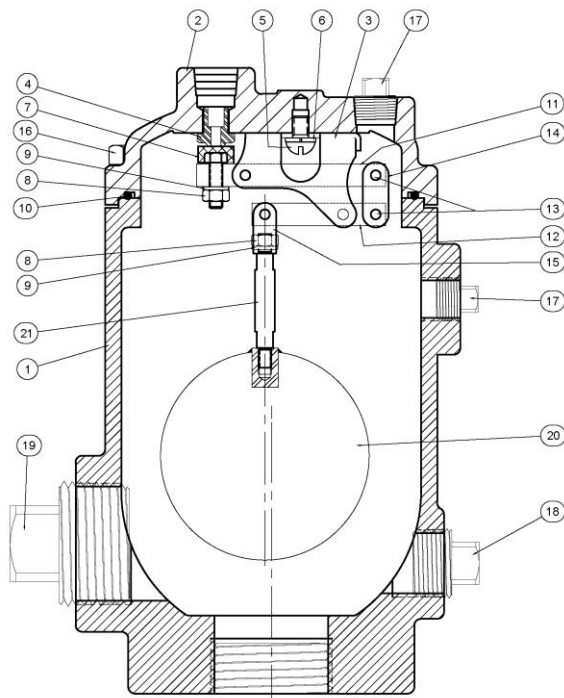

**Figure 929 Parts List**

Item	Description	Standard Material
1	Body	Cast Iron
2	Cover	Cast Iron
3	Leverage Bracket	316 Stainless Steel
4	Orifice	316 Stainless Steel
5	Bracket Screw	304 Stainless Steel
6	Lock Washer	410 Stainless Steel
7	Orifice Button	Buna-N Rubber/SS
8	Hex Nut	304 Stainless Steel
9	Lock Washer	410 Stainless Steel
10	O-Ring	Buna-N Rubber
11	Lever Arm	316 Stainless Steel
12	Float Arm	316 Stainless Steel
13	Spring Pin	302 Stainless Steel
14	Valve Link	316 Stainless Steel
15	Pivot Link	316 Stainless Steel
16	Cover Bolt	Zinc Plated Steel
17	1/2" Pipe Plug	Steel
18	1" Pipe Plug	Cast Iron
19	2" Pipe Plug	Cast Iron
20	Float Ball	316 Stainless Steel
21	Float Rod	316 Stainless Steel

## VAG USA, LLC

234 Clay Avenue • Mars, PA 16046 USA  
 Phone: 724-776-1020 • Fax: 724-776-1020

[info-ga@vag-group.com](mailto:info-ga@vag-group.com)

[www.gaindustries.com](http://www.gaindustries.com)