

INSTALLATION, OPERATION AND MAINTENANCE MANUAL

Figures 930-T, 930-DT, 930-UT

**1/2" to 4" Air & Vacuum Valves
for Clean Water**

Drawings EAV-7051, EAV-7052, EAV-7053



234 Clay Avenue • Mars, PA 16046 USA
Telephone (724) 776-1020 • Fax (724) 776-1254
E-mail: info-ga@vag-group.com

Manual Number 931.1-IOM 120220



WARNING: Cancer and Reproductive Harm – www.Prop65Warnings.ca.gov

INSTALLATION, OPERATION and MAINTENANCE

Figure 930 Air & Vacuum Valves

INTRODUCTION

This manual will provide the information to properly install, operate and maintain the valve to ensure a long service life. The Figure 930 Air & Vacuum Valve is ruggedly constructed to provide years of trouble-free operation with minimal maintenance.

These Air & Vacuum Valves are not intended for use with fluids containing suspended solids such as wastewater and sewage. The GA Industries Figure 935 or 939 Sewage Service Air & Vacuum Valves are recommended for such applications.

CAUTION

The valve is NOT recommended for use with toxic fluids, fuels or fluids containing hazardous gases

The Shop Order (SO) Number, Figure Number, size and pressure rating are stamped on a nameplate attached to the valve. Please refer to the SO number when ordering parts.

DESCRIPTION OF OPERATION

The Figure 930 allows air that is being pushed ahead of the incoming fluid to escape and ensure a complete filling of the pipeline or vessel. Once the air has been exhausted and the system is pressurized the valve closes tight. It does not re-open unless and until the system is drained and/or a negative pressure condition occurs within the pipe or vessel in order to admit air to minimize the vacuum condition.

The Figure 930 employs the Kinetic aerodynamic operating principle designed to ensure the valve is not prematurely blown shut by the high velocity exiting air.

RECEIVING AND STORAGE

Inspect the valve upon receipt for damage during shipment. Carefully unload all valves to the ground without dropping. Do not pick up the valve by the "cowl."

The valves should remain in a clean, dry and weather protected area until installed. For long term storage (greater than 6 months) the rubber surfaces of the seat should be coated with a non-toxic lubricant such as "SuperLube" made by Synco Chemical. Do not expose the rubber parts to sunlight or ozone.

INSTALLATION

The Figure 930 is standard with NPT inlet and outlet connections in sizes ½" to 3" while the 4" is standard with ANSI Class 125 or 250 flanged inlet and NPT outlet. The inlet and outlet connections are the same size. Consult the drawings of record to verify the configuration supplied and installed.

The valve must be installed in an upright vertical orientation, normally at a high point in the system.

If installed outdoors, below ground in a vault or in an unheated area, adequate freeze protection must be provided. Some discharge of water may occur just prior to valve closure. If installed indoors or in a vault, the valve outlet should be directed to an adequate drain.

An isolating valve should be installed between the valve and the pipeline or system to facilitate maintenance.

Carefully screw threaded end valves onto pipe nipple using compatible thread sealant. Tighten valve using wrench flats. DO NOT OVERTIGHTEN.

Flat-faced flanged valves should be mated with flat-faced flanges and full-face gaskets. If ring gaskets are used the bolt material shall be ASTM A307 Grade B (or equivalent). Higher strength bolting should only be used with full-face gaskets.

Lower heavy valves using slings or chains around the valve body and/or the lifting eye. Lubricate the bolts or studs and insert around flange. Lightly tighten bolts until gaps are

eliminated. Torque bolts in an alternating pattern in graduated steps. If leakage occurs wait 24 hours and re-torque the bolts but do not compress the gasket more than 50% or exceed bolt maximum torque rating.

VALVE CONSTRUCTION

The standard Figure 930 Air & Vacuum Valve has a cast iron body and cover, a 316 stainless steel float ball and Buna-N rubber seat. Refer to the List of Materials submitted for the order if non-standard materials were provided.

Refer to Figure 1 or 2 on Page 3 for details of construction and parts location.

All Figure 930 Air & Vacuum Valves have a 10 PSI minimum working pressure. Maximum working pressure for Figure 930-DT Class 125 flanged inlet valves is 150 PSI. Figure 930-T NPT inlet and Figure 930-UT Class 250 flanged inlet valves have a 300 PSI maximum working pressure.

The body (1) has an inlet connection at the bottom where the valve attaches to the system and an outlet connection at the top through which air leaves the valve (during filling) and enters the valve (during draining). The outlet may be fitted with a "cowl" to deflect air during venting and minimize entry of foreign matter during air admission.

<p style="text-align: center;">WARNING</p> <p style="text-align: center;">Removing the valve from the line or disassembling the valve while there is pressure in the valve body may result in injury or damage to the valve</p>
--

PREVENTIVE MAINTENANCE

Figure 930 Air & Vacuum Valves require no scheduled lubrication, adjustment or preventive maintenance.

The float ball with attached float guide are the only moving parts and require no lubrication.

A periodic visual inspection should be performed to ensure the outlet piping is not obstructed and to verify there is no fluid leakage.

TESTING

Valve operation can be easily tested. Close the inlet isolation valve and remove or loosen the pipe plug nearest the inlet to drain the water

from the valve. The float should drop as the water leaves the valve. NOTE: A ball or gate valve can be installed in place of the pipe plug to facilitate testing.

Replace or tighten the pipe plug and slowly open the inlet isolating valve. The valve should float closed and seat tightly.

TROUBLESHOOTING

- Valve Does Not Close / Fluid Leakage
Verify debris has not collected on the seat preventing tight closure

Verify there is at least 10 PSI pressure at the valve inlet

Verify rubber seat and/or float ball seating surfaces are not deformed or damaged

Verify float guide is undamaged and attached to float

Verify float has buoyancy

Verify float ball rises freely without binding or sticking

- Valve Does Not Open
Verify there is no debris in the valve that is preventing the float from freely falling when fluid is drained from valve

DISASSEMBLY

Although small a size Figure 930 Air & Vacuum Valve may be more easily serviced by removing it from the line, all valves can be serviced while the body remains connected to the pipeline. A skilled technician with proper tools should perform all work. No special tools are required.

First ensure there is no pressure within the valve. Remove the cover screws (7) and lift off cover (2), it may be necessary to pry the cover off.

Remove the rubber seat (3) and lift out the float ball (5) with float guide (8) attached. Remove the rubber cushion (9) and flange bearing (10).

Inspect all parts for wear and damage. Minor scratches in the float are normal. Some floats may contain sand for added weight but if water is detected replace the float. Clean any scale build up from the float ball. Replace damaged parts.

REASSEMBLY

Reassembly is performed in reverse order from disassembly. Clean all parts especially the threaded, seating and sealing surfaces before reassembling valve. Worn or damaged parts should be replaced.

Carefully introduce pressure and check for leaks

REPAIR KITS

Soft Goods Repair Kits are available and include Items 3 and 9. Order by kit number or part number:

- 1/2" to 1" Kit A930 Part Number 2-80-11000-011
- 2" Kit A930-2 Part Number 2-80-11000-014
- 3" Kit A930-3 Part Number 2-80-11000-015
- 4" Kit A930-4 Part Number 2-80-11000-016

Other parts are ordered individually.

REPLACEMENT PARTS

Genuine replacement parts are available from your local VAG/GA Industries representative or from the factory:

VAG USA, LLC
 234 Clay Avenue
 Mars, PA 16046 USA
 Telephone: 724-776-1020
 Fax: 724-776-1254
 E-mail: quotes-ga@vag-group.com

Please have the nameplate data available when ordering parts.

WARRANTY

The Warranty for GA Industries valves is included in our Terms and Conditions which can be found here: <https://gaindustries.com/terms>

PARTS LIST
 1/2" to 4" Figure 930

Item	Name	Standard Material
1.	Body	Cast Iron
2.	Cover	Cast Iron
3.	Seat	Buna-N Rubber
4.	Cover Bolts	Steel, Zinc Plated
5.	Float Ball	316 Stainless Steel
6.	Pipe Plug	Malleable Iron
7.	Cover Nuts	Steel, Zinc Plated
8.	Float Guide	1/2" - 3" UHMW Polyethylene 4" - Stainless Steel
9.	Cushion	Buna-N Rubber
10.	Bearing	Acetal Polymer

VAG USA, LLC
 234 Clay Avenue • Mars, PA 16046 USA
 Phone: 724-776-1020 • Fax: 724-776-1020
info-ga@vag-group.com •
www.gaindustries.com

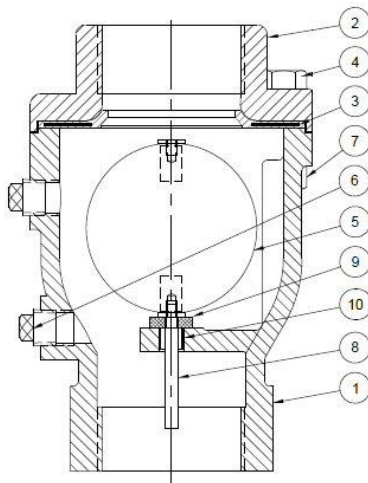

Figure 1
 NPT Inlet

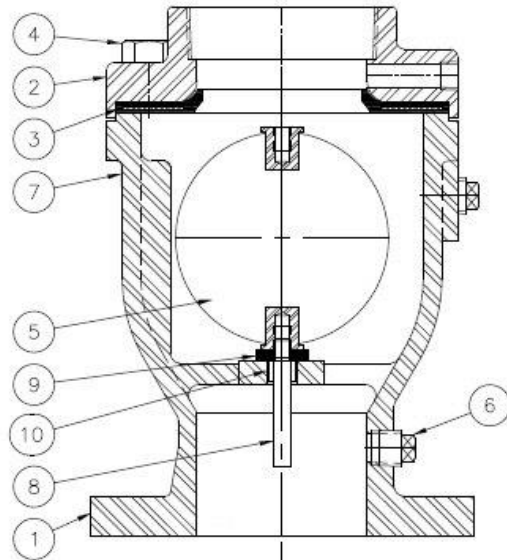

Figure 2
 Flanged Inlet