

INSTALLATION, OPERATION AND MAINTENANCE MANUAL

Figures 930-D, 930-U

10" & 12" Air & Vacuum Valves for Clean Water



234 Clay Avenue • Mars, PA 16046 USA
Telephone (724) 776-1020 • Fax (724) 776-1254
E-mail: info-ga@vag-group.com

Manual Number 930.3-IOM 111420



WARNING: Cancer and Reproductive Harm – www.Prop65Warnings.ca.gov

INSTALLATION, OPERATION and MAINTENANCE

Figures 930-D, 930-U Air & Vacuum Valves

INTRODUCTION

This manual will provide the information to properly install, operate and maintain the valve to ensure a long service life. The Figure 930 Air & Vacuum Valve is ruggedly constructed to provide years of trouble-free operation with minimal maintenance.

These Air & Vacuum Valves are not intended for use with fluids containing suspended solids such as wastewater and sewage. The GA Industries Figure 935 Sewage Service Air & Vacuum Valves are recommended for such applications.

CAUTION

The valve is NOT recommended for use with toxic fluids, fuels or fluids containing hazardous gases

The Shop Order (SO) Number, Figure Number, size and pressure rating are stamped on a nameplate attached to the valve. Please refer to the SO number when ordering parts.

DESCRIPTION OF OPERATION

The Figure 930 Air & Vacuum Valve allows air that is being pushed ahead of the incoming fluid to escape and ensure a complete filling of the pipeline or vessel. Once the air has been exhausted and the system is pressurized the valve closes tight. It does not re-open unless and until the system is drained and/or a negative pressure condition occurs within the pipe or vessel in order to admit air to minimize the vacuum condition.

The Figure 930 employs the Kinetic aerodynamic operating principle to ensure the valve is not prematurely blown shut by the high velocity exiting air.

RECEIVING AND STORAGE

Inspect the valve upon receipt for damage during shipment. Carefully unload all valves to the ground without dropping. Do not pick up the

valve by the "cowl." The valves should remain in a clean, dry and weather protected area until

installed. For long term storage (greater than 6 months) the rubber surfaces of the seat should be coated with a non-toxic lubricant such as "SuperLube" made by Synco Chemical. Do not expose the rubber parts to sunlight or ozone.

INSTALLATION

Figure Numbers suffixed with "D" (e.g., 930-D) indicate the valve has ANSI Class 125 flanged pipeline connection. Figure Numbers suffixed with "U" (e.g., 930-U) indicate the valve has ANSI Class 250 flanged pipeline connection.

Sizes 10" & 12" Figure Numbers 930-D and 930-U are standard with an outlet cowl, indicated by a "C" (e.g., 930-DC). In lieu of a cowl, the valve can be supplied with an ANSI Class 125 flanged outlet connection, indicated by a "J" (e.g., 930-UJ).

Consult the drawings of record to verify the configuration supplied and installed.

The valve must be installed in an upright vertical orientation, normally at a high point in the system.

If installed outdoors, below ground in a vault or in an unheated area, adequate freeze protection must be provided. Some discharge of water may occur just prior to valve closure. If installed indoors or in a vault, the valve outlet should be directed to an adequate drain.

An isolating valve should be installed between the valve and the pipeline or system to facilitate maintenance.

Carefully screw threaded end valves onto pipe nipple using compatible thread sealant. Tighten valve using wrench flats. DO NOT OVER-TIGHTEN.

Flat-faced flanged valves should be mated with flat-faced flanges and full-face gaskets. If ring

gaskets are used the bolt material shall be ASTM A307 Grade B (or equivalent). Higher strength bolting should only be used with full-face gaskets.

Lower heavy valves using slings or chains around the valve body and/or the lifting eye. Lubricate the bolts or studs and insert around flange. Lightly tighten bolts until gaps are eliminated. Torque bolts in an alternating pattern in graduated steps. If leakage occurs wait 24 hours and re-torque the bolts but do not compress the gasket more than 50% or exceed bolt maximum torque rating.

VALVE CONSTRUCTION

The standard Figure 930 Air & Vacuum Valve has a cast iron body and cover, a 316 stainless steel float ball, Buna-N rubber seat and an outlet cowl. Refer to the List of Materials submitted for the order if non-standard materials were provided.

Refer to Page 4 for details of construction and parts location.

The body (1) has an inlet connection at the bottom where the valve attaches to the system and an outlet connection at the top through which air leaves the valve (during filling) and enters the valve (during draining). The outlet may be fitted with a "cowl" to deflect air during venting and minimize entry of foreign matter during air admission or a flanged connection to permit the outlet to be piped to a drain.

WARNING

Removing the valve from the line or disassembling the valve while there is pressure in the valve body may result in injury or damage to the valve

PREVENTIVE MAINTENANCE

Figure 930 Air & Vacuum Valves require no scheduled lubrication, adjustment or preventive maintenance.

The float ball with attached float guide are the only moving parts and require no lubrication.

A periodic visual inspection should be performed to ensure the outlet piping is not obstructed and to verify there is no fluid leakage.

TESTING

Valve operation can be easily tested. Close the inlet isolation valve and remove or loosen the pipe plug nearest the inlet to drain the water from the valve. The float should drop as vacuum forms inside the valve as the water leaves. NOTE: A ball or gate valve can be installed in place of the pipe plug to facilitate testing.

Replace or tighten the pipe plug and slowly open the inlet isolating valve. The valve should float closed and seat tightly when pressurized.

TROUBLESHOOTING

- Valve Does Not Close / Fluid Leakage
Verify debris has not collected on the seat preventing tight closure

Verify the pressure at the valve inlet is at least 10 PSI

Verify rubber seat and/or float ball seating surfaces are not deformed or damaged

Verify float guide is undamaged and attached to float

Verify float has buoyancy

Verify float ball rises freely without binding or sticking

- Valve Does Not Open
Verify there is no pressure inside the valve.

Verify there is no debris in the valve that is preventing the float from freely falling when fluid is drained from valve

DISASSEMBLY

Although small a size Figure 930 Air & Vacuum Valve may be more easily serviced by removing it from the line, all valves can be serviced while the body remains connected to the pipeline. A skilled technician with proper tools should perform all work. No special tools are required.

First ensure there is no pressure within the valve. Remove the cover bolts and nuts (4 and 8) and lift off cover (2), it may be necessary to pry the cover off.

Lift out the float ball (10) with float guide (9) attached. Remove the rubber cushion (8) and flange bearing (13).

Invert cover and remove O-ring (6), seat screws (5), follower ring (4) and seat (3).

Inspect all parts for wear and damage. Minor scratches in the float are normal. Some floats may contain sand for added weight but if water is detected replace the float. Clean any scale build up from the float ball. The float ball (10) can be inverted to obtain a fresh sealing surface. Replace damaged parts.

REASSEMBLY

Reassembly is performed in reverse order from disassembly. Clean all parts especially the threaded, seating and sealing surfaces before reassembling valve. Worn or damaged parts should be replaced.

Carefully introduce pressure and check for leaks.

REPLACEMENT PARTS

Genuine replacement parts are available from your local VAG/GA Industries representative or from the factory:

VAG USA, LLC
 234 Clay Avenue
 Mars, PA 16046 USA
 Telephone: 724-776-1020
 Fax: 724-776-1254
 E-mail: quotes-ga@vag-group.com

Please have the nameplate data available when ordering parts.

REPAIR KITS

Soft Goods Repair Kits
 10" Kit A930-10 Part Number 2-80-11000-012
 12" Kit A930-12 Part Number 2-80-11000-013

Soft goods kit contains items 3, 6 and 8

All other parts ordered individually

WARRANTY

The Warranty for GA Industries valves is included in our Terms and Conditions which can be found here: <https://gaindustries.com/terms>

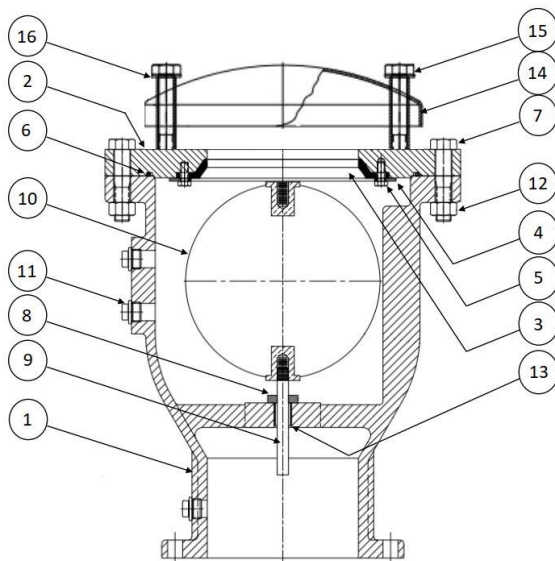

PARTS LIST
 10" and 12" Figures 930-D, 930-U

Item	Name	Standard Material
1.	Body	Cast Iron
2.	Cover	Cast Iron
3.	Seat	Buna-N Rubber
4.	Follower Ring	316 Stainless Steel
5.	Seat Screws	304 Stainless Steel
6.	Cover O-ring	Buna-N Rubber
7.	Cover Bolt	Steel, Zinc Plated
8.	Cushion	Buna-N Rubber
9.	Float Guide	303 Stainless Steel
10.	Float Ball	316 Stainless Steel
11.	Pipe Plug	Steel
12.	Cover Nut	Steel, Zinc Plated
13.	Guide Bearing	Acetal Copolymer
14.	Cowl	Steel
15.	Cowl Bolt	Zinc Plated Steel
16.	Cowl Washer	Zinc Plated Steel

Note: Parts 14, 15 & 16 not supplied on Figure 930-DJ or 930-UJ Air & Vacuum Valves with flanged outlet.