

2", 3" & 4" Figures 930-DT, 930-UT Air & Vacuum Valve for Clean Water

Description

GA Industries Figures 930-D and 930-U Air & Vacuum Valves efficiently vent air from pipelines and systems as they are being filled with water and then close tight once the system is full and pressurized. They automatically open to admit air to limit vacuum formation when the pipeline or system is drained and/or a negative pressure occurs in the valve.

Air & Vacuum Valves are typically installed at system high points where air naturally rises during filling and vacuum first forms during draining.

Figures 930-D and 930-U only have one moving part and such simple construction ensures dependable, long-term operation.

Product Features

- Compact and light weight
- Full port orifice for maximum air outflow and inflow
- Utilizes "kinetic" operating principle, designed not to blow shut
- Rugged iron body and cover
- Corrosion resistant Type 316 stainless steel float
- Tight sealing and easily replaceable rubber seat

Standard Materials

- Body & Cover Cast Iron, ASTM A126 Class B
- Float Stainless Steel, Type 316
- Replaceable Seat Buna-N
- External Fasteners Steel, A307, Zinc Plated
- Coating Internal and External NSF-61 Certified Epoxy

Non-Shock Working Water Pressure at up to 150F (66C)		
Inlet Size	2", 3" and 4"	
Figure Number	930-D	930-U
Inlet Connection	ANSI Class 125	ANSI Class 250
Outlet Size	Same as Inlet	
Standard Outlet	NPT	NPT
Working Pressure	10-200 PSI	10-300 PSI
Pressure Rating	200 PSI	300 PSI
Hydro Test	300 PSI	450 PSI



Approvals & Certifications

- Complies with AWWA Standard C512
- NSF-61 Certified for Contact with Drinking Water
- NSF-372 Certified Lead Free (Max 0.25% Lead Content by Weighted Average)

Options/Accessories

- Option BA Build America/Buy America (BABA) and American Iron and Steel (AIS) Compliant
- Option IV Inlet Isolating Valve – lever operated AWWA butterfly valve (3" & 4" Class 125 flanged valves only)
- Option OC Outlet cowl in lieu of standard NPT outlet
- Option SE 316 stainless steel external fasteners
- Option US American Iron and Steel (AIS) Compliant

Ordering Data

- Figure Number (930-DT, 930-UT)
- Size
- Options/Accessories

Data Sheet 930.02G

Pressure at Valve Inlet	Air Outflow Rate Standard Cubic Feet/Min (SCFM)		
	2"	3"	4"
1 PSI	314	707	1260
2 PSI	444	1000	1780
3 PSI	544	1220	2180
4 PSI	628	1410	2510
5 PSI	703	1580	2810
7 PSI	831	1870	3320
10 PSI	994	2240	3970
15 PSI	1217	2740	4870

Value is rate at which air is vented from pipeline/system during filling at valve inlet pressures shown. Inlet pressure during filling should not exceed 5 PSI. Multiply SCFM air venting rate x 7.48 to convert to equivalent pipeline/system liquid filling rate in USGPM.

Pressure at Valve Inlet	Air Inflow Rate Standard Cubic Feet/Min (SCFM)		
	2"	3"	4"
-1 PSIG	320	721	1280
-2 PSIG	453	1020	1810
-3 PSIG	555	1250	2220
-4 PSIG	641	1440	2560
-5 PSIG	716	1610	2870

Value is rate at which air is drawn into the valve at negative pipeline/system pressure shown. Multiply SCFM air inflow rate x 7.48 to convert to equivalent pipeline/system liquid draining rate in USGPM.

OUTLET COWL and/or INLET ISOLATING AWWA BUTTERFLY VALVE

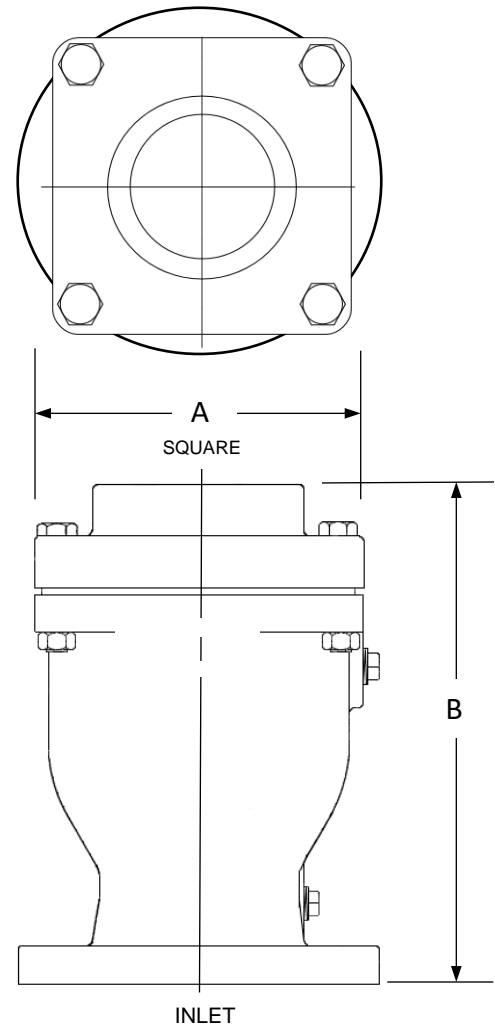
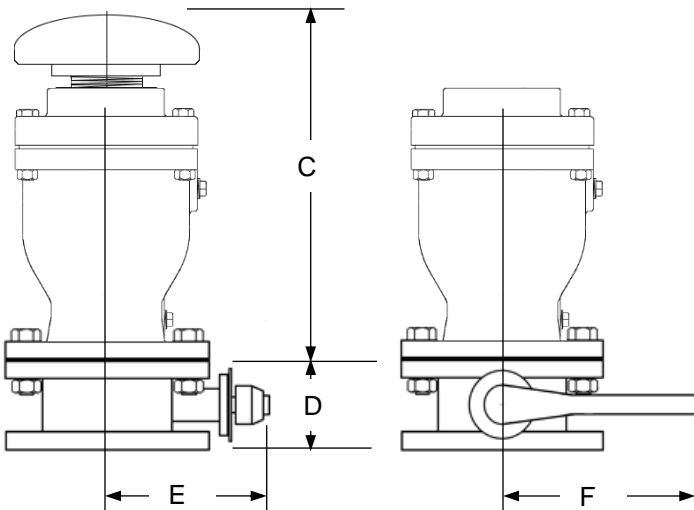

Installation Dimensions

SIZE		2"	3"	4"
A		5 ³ / ₈ "	6 ⁵ / ₈ "	8 ¹ / ₄ "
B		10"	10 ⁵ / ₈ "	12 ⁵ / ₈ "
C		12 ¹ / ₂ "	13 ¹ / ₂ "	16 ¹ / ₄ "
D		Not Applicable	5"	5"
E		Not Applicable	8"	8 ¹ / ₂ "
F		Not Applicable	10 ¹ / ₄ "	10 ¹ / ₄ "
Valve Wgt.	Class 125	24 lbs.	50 lbs.	85 lbs.
	Class 250	27 lbs.	55 lbs.	95 lbs.
Add for Class 125 Inlet Isolating BFW		Not Available	28 lbs.	39 lbs.
Add for Outlet Cowl		1 lb.	2 lb.	3 lbs.

All dimensions and weights are approximate. Request certified drawings if critical.