

# Figures 933-T, 933-D, 933-U

## Well Service Air & Vacuum Valve with Double Acting Throttle Device

### Description

GA Industries Figure 933 Air & Vacuum Valves are typically installed between a turbine pump and its check or pump control valve. The Figure 933 efficiently vent airs from the turbine pump column at pump start and admits air into the column at pump shutdown.

The Figure 933 includes a specially designed double acting throttle device to allow an adjustable, regulated air venting rate but unrestricted air admission.

The air valve only has one moving part, and its simple construction ensures dependable, long-term operation.

### Product Features

- Compact and light weight
- Adjustable, regulated air discharge rate
- Unrestricted air inflow rate
- Utilizes "kinetic" operating principle, designed not to blow shut
- Rugged iron body and cover
- Corrosion resistant Type 316 stainless steel float
- Tight sealing and easily replaceable rubber seat

### Standard Materials

- Body & Cover Cast Iron, ASTM A126 Class B
- Float Stainless Steel, Type 316
- Replaceable Seat Buna-N
- External Fasteners Steel, A307, Zinc Plated

### Coating

- Standard: Uncoated internal, external enamel primer, 2 mil DFT
- Optional See Option P2



### Approvals & Certifications

- Complies with AWWA Standard C512

### Options/Accessories

- Option IV Inlet Isolating Valve – lever operated bronze ball valve (NPT Inlet), or lever operated butterfly valve (Class 125 flanged inlet)
- Option P2 316 Stainless Steel external fasteners and internal/external Carboline 891 NSF-61 certified 2-part epoxy, 6 mil DFT

### Ordering Data

- Figure Number (933-T, 933-D, 933-U)
- Size
- Options/Accessories

Non-Shock Working Water Pressure at up to 150F (66C)			
Figure No.	933-T	933-D	933-U
Inlet Size/Type	½" to 3" NPT	4" CL 125 Flange	4" CL 250 Flange
Outlet Size/Type	NPT, Same Size as Inlet		
Working Pressure	10 - 300 PSI	10 – 200 PSI	10 – 300 PSI
Pressure Rating	300 PSI	200 PSI	300 PSI
Hydro Test	450 PSI	300 PSI	450 PSI

### Data Sheet 933.01D

Pressure at Valve Inlet	Max Air Outflow Rate, Throttle Device Fully Open Standard Cubic Feet/Min (SCFM)					
	1/2"	3/4"	1"	2"	3"	4"
1 PSI	19.6	44.2	78.5	314	707	1260
2 PSI	27.8	62.5	111	444	1000	1780
3 PSI	34.0	76.5	136	544	1220	2180
4 PSI	39.3	88.4	157	628	1410	2510
5 PSI	43.9	98.8	176	703	1580	2810
7 PSI	52.0	117	208	831	1870	3320
10 PSI	62.1	140	248	994	2240	3970
15 PSI	75.2	169	304	1217	2740	4870

Value is maximum rate at which air can be vented from pump column at pressures shown. Multiply SCFM air venting rate x 7.48 to convert to equivalent liquid filling rate in USGPM.

Pressure at Valve Inlet	Air Inflow Rate, Standard Cubic Feet/Min (SCFM)					
	1/2"	3/4"	1"	2"	3"	4"
-1 PSIG	20.0	45.2	80	320	721	1280
-2 PSIG	28.3	63.9	113	453	1020	1810
-3 PSIG	34.7	78.3	138	555	1250	2220
-4 PSIG	40.1	90.4	160	641	1440	2560
-5 PSIG	44.9	101	179	716	1610	2870

Value is rate at which air is drawn into the valve at negative pipeline/system pressure shown. Multiply SCFM air inflow rate x 7.48 to convert to equivalent pipeline/system liquid draining rate in USGPM.

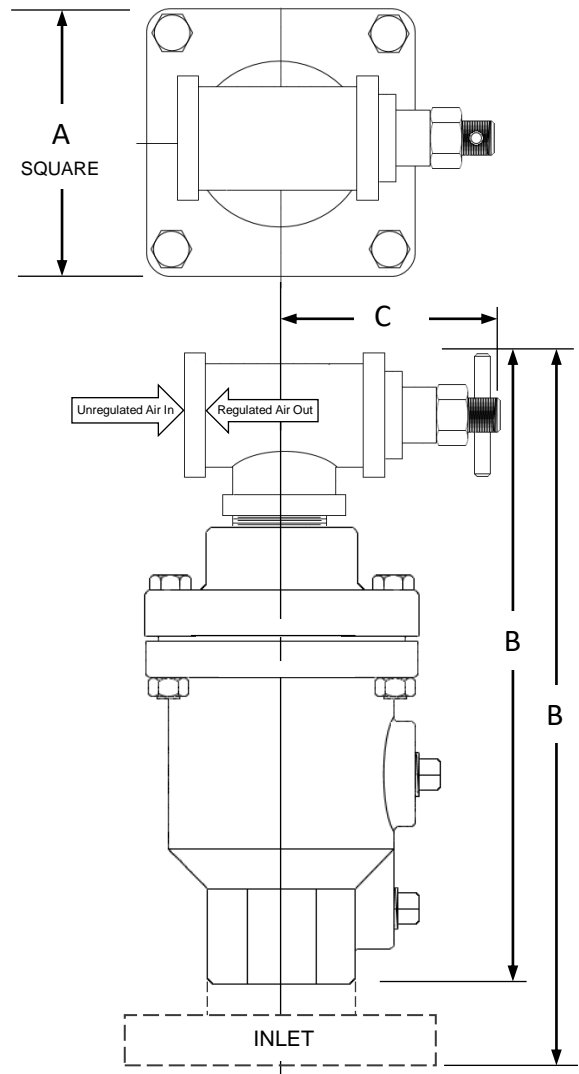

### Installation Dimensions

SIZE	1/2", 3/4", 1"	2"	3"	4"
A	3 3/8"	5 5/8"	6 5/8"	8 1/4"
B	10 3/4"	13 1/2"	17 1/2"	19 1/4"
C (Min/Max)	3 1/2"/6 1/8"	3 3/8"/6 1/8"	5" 9/4"	5 3/4"/10"
D	4"	5"	8"	5"
E	9 3/4"	11 1/4"	10 1/2"	10 1/4"
Valve Weight	15 lbs.	28 lbs.	50 lbs.	105 lbs.
Add for Inlet Isolating Valve	2 lbs.	8 lbs.	20 lbs.	53 lbs.

All dimensions and weights are approximate. If critical request certified drawings

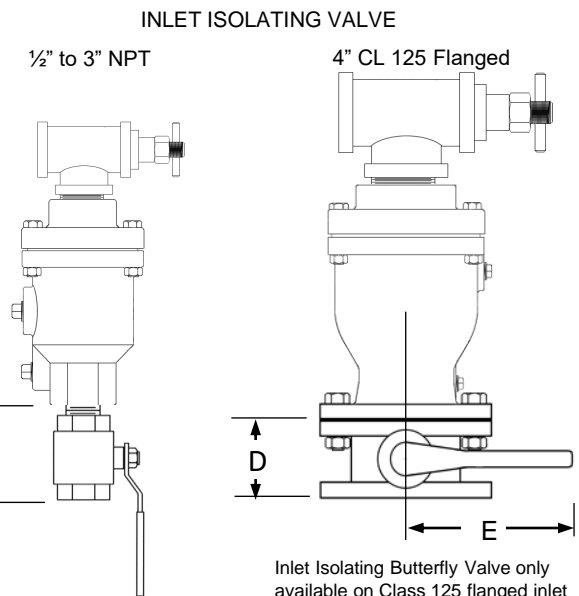

Inlet Isolating Butterfly Valve only available on Class 125 flanged inlet