

INSTALLATION, OPERATION AND MAINTENANCE MANUAL

FIGURE 935

3", 4" & 6" Drawings EAV-7132, EAV-7119 AIR & VACUUM VALVES FOR SEWAGE & WASTEWATER

TABLE OF CONTENTS

Introduction	2
Description of Operation	2
Receiving & Storage	2
Installation	2
Valve Construction	3
Preventive Maintenance	3
Trouble Shooting	3
Disassembly.....	3, 4
Reassembly	4
Backflushing Instructions	5
Order Replacement Parts	5
Warranty	5
Figure 942 Drawing/Parts List	6



234 Clay Avenue • Mars, PA 16046 USA
Telephone (724) 776-1020 • Fax (724) 776-1254
E-mail: info-ga@vag-group.com



WARNING: Cancer and Reproductive Harm – www.Prop65Warnings.ca.gov

INSTALLATION, OPERATION and MAINTENANCE

Figure 935 Sewage Air & Vacuum Valves

INTRODUCTION

This manual will provide the information to properly install, operate and maintain the valve to ensure a long service life. The GA Industries Figure 935 Air & Vacuum Valve is ruggedly constructed to provide years of trouble-free operation with minimal maintenance.

CAUTION

The valve is NOT recommended for use with toxic fluids, fuels or fluids containing hazardous gases

CAUTION

The valve will not function if used at a pressure higher than the maximum working pressure indicated on the nameplate.

The Shop Order (SO) Number, Figure Number, size and pressure rating are stamped on a nameplate attached to the valve. Please refer to the SO number when ordering parts.

DESCRIPTION OF OPERATION

The Figure 935 Air & Vacuum Valve is designed to vent air through its large orifice as the system is being filled with liquid and close tight when the system is full and pressurized. The valve automatically opens to admit air through the large orifice during draining or when the internal pressure falls below atmospheric.

These valves are usually installed at high points in the system where air tends to collect and vacuum conditions initially form during draining. When empty of liquid, the valve is open allowing air to be vented ahead of incoming liquid. The float rises when water enters the valve and closes the orifice. As air is released

Should the pressure inside the valve fall below atmospheric both the large and small orifices open to allow air to be drawn into the system to alleviate vacuum conditions.

RECEIVING AND STORAGE

Inspect the valve upon receipt for damage during shipment. Carefully unload all valves to the ground without dropping.

The valves should remain in a clean, dry and weather protected area until installed. For long term storage (greater than 6 months) the rubber surfaces of the seat should be coated with a non-toxic lubricant such as "SuperLube" made by Synco Chemical. Do not expose the rubber parts to sunlight or ozone.

INSTALLATION

Sizes 3" and 4" Figure 935 can be supplied with an NPT or Class 125 pipeline connection; the 6" has Class 125 flanged pipeline connection.

Consult the drawings of record to verify the configuration supplied and installed.

The valve must be installed in an upright vertical orientation, normally at a high point in the system.

If installed outdoors, below ground in a vault or in an unheated area, adequate freeze protection must be provided.

An isolating valve should be installed between the valve and the pipeline or system to facilitate maintenance (included with backflushing attachments).

Carefully screw threaded end valves onto pipe nipple using compatible thread sealant. Tighten valve using wrench flats. DO NOT OVERTIGHTEN.

Flat-faced flanged valves should be mated with flat-faced flanges and full-face gaskets. If ring gaskets are used the bolt material shall be ASTM A307 Grade B (or equivalent). Higher strength bolting should only be used with full-face gaskets.

Lower heavy valves over the mating flange using slings or chains around the valve body. Lubricate the bolts or studs and insert around flange. Lightly tighten bolts until gaps are eliminated. Torque bolts in an alternating pattern in graduated steps. If leakage occurs wait 24 hours and re-torque the bolts but do not compress the gasket more than 50% or exceed bolt maximum torque rating.

VALVE CONSTRUCTION

The standard Figure 935 Sewage Air & Vacuum Valve has a cast iron body, 316 stainless steel float, plug, seat and linkage mechanism and a Buna-N rubber seat. It has a working pressure range of 10 to 200 PSI. Optional materials can be provided for higher working pressures. Refer to the List of Materials submitted for the order if non-standard materials were provided.

Refer to Page 6 for details of construction and parts location.

The valve has an inlet connection at the bottom where the valve attaches to the system and an outlet connection at the top through which air exits and enters the valve.

WARNING

Removing the valve from the line or disassembling the valve while there is pressure in the valve body may result in injury or damage to the valve

PREVENTIVE MAINTENANCE

Figure 935 Sewage Air & Vacuum Valves require no scheduled lubrication or adjustment.

A periodic visual inspection should be performed to ensure the outlet piping is not obstructed and to verify there is no fluid leakage.

Depending on the nature of the fluid, sewage air valves may become clogged with sediment or grease and require periodic cleaning. To facilitate such cleaning GA Industries air valves with an "F" at the end of the Figure Number (e.g., 935F) were supplied with "backflushing attachments." Refer to the backflushing instructions on Page 4 of this manual for additional information.

TESTING

Valve operation can be easily tested. Close the inlet isolation valve and remove or loosen the pipe plug nearest the inlet to drain the water

from the valve. The float should drop as the water leaves the valve. NOTE: A manual valve can be installed in place of the pipe plug to facilitate testing (valves are included with backflushing attachments).

Replace or tighten the pipe plug and slowly open the inlet isolating valve. After expelling air, the valve should close and seal tightly.

TROUBLESHOOTING

- Valve Does Not Close / Fluid Leakage
Verify there is at least 10 PSI at the valve inlet for tight sealing

Verify debris has not collected on the seat preventing tight closure

Verify rubber seating surfaces are not damaged

Verify float has buoyancy

Verify linkage mechanism operates freely without binding or sticking

- Valve Does Not Open
Verify debris in the valve is not preventing the float from freely falling when fluid is drained from valve

Verify linkage mechanism operates freely without binding or sticking

DISASSEMBLY

While small valves may be more easily serviced by removing it from the line, all valves can be serviced while the body remains connected to the pipeline. A skilled technician with proper tools should perform all work. No special tools are required.

Disassemble the valve only as far as needed to replace damaged or worn parts.

First ensure there is no pressure within the valve. Refer to Pages 5 and 6 for parts location and identification.

Remove the cover bolts (9) and lift off cover (2) with float and linkage attached. It may be necessary to pry the cover off. Be careful not to damage or lose the cover O-ring (6).

Remove the spring pin (15) to free the Universal Coupling (13) from the connector (11). Remove

the cage bolts (23) and lift cage from cover. Unscrew the seat (4) from the cage (3) and remove the plug (5) and bushing (12). Note: Bushing only used in 6" valves or smaller valves with ductile iron cage. Remove the cage O-ring (7) and renewable seat (8) from the seat (4).

If necessary, remove upper (10) plug extensions from the plug (5). The extension is secured to the plug with Loctite so it may be necessary to apply heat to remove them.

Remove spring pins (15) from universal coupling freeing it from the float rod (14).

The float ball (20) is removed by loosening the hex nut (24) and unscrewing the float ball (20) by hand being careful not to lose the lock washer (16). Note: the hex nut and lock washer is not used on the 6" size valve. It may be necessary to apply some heat to unscrew the float from the float rod.

Remove the float hood (21) by removing the cap screw (22) and lock washer (16).

Inspect all parts for wear and damage. Minor scratches and dents in the float are normal. Replace the float if water is detected inside of it. Replace damaged parts.

REASSEMBLY

Clean all parts especially seating and sealing surfaces before reassembling valve. Worn parts should be replaced during re-assembly.

Apply Loctite 263 threads on the upper extension (23) and the connector (11). Tightly screw the upper extension into the stem on the concave side of the plug (5) and the connector (11) into the stem on the opposite end.

Install bushing (12) and plug (5) in seat (4), lubricate and install renewable seat (8) in seat (4). Install plug (5) with upper extension and connector attached into bushing. Screw seat (4) into cage ensuring renewable seat remains in place. Install cage O-ring (7), position cage on cover and install cage bolts (27) and tighten.

Install spring pins (15) in universal coupling (13) to connect it to float rod (14) and connector (11).

Install hex nut (24) and lock washer (16) on end of float rod (not required on 6" valve) and apply

Loctite 263 to threads. Screw float ball (20) onto float rod (14) and tighten.

Apply Loctite 380 to float cap screw (22) and install lock washer (16) and float hood (21) onto bottom of float (20).

Verify plug and attached float and linkage freely falls away from seat when allowed to drop.

Lubricate and install cover O-ring (6) in cover and place on top of valve body (1) being careful O-ring remains in place. Install cover bolts (9) and tighten in a cross over pattern.

Re-install on pipeline slowly introduce pressure and ensure valve closes tightly.

BACKFLUSHING INSTRUCTIONS

Follow all local cross-connection and safety codes and regulations!

To determine if a GA Industries sewage air valve needs cleaning or backflushing:

- Close the inlet isolating valve then slowly open the 1/2" flushing ball valve (if installed) or slowly remove the pipe plug at the top of air valve to relieve internal pressure.
- Open the 1" blow off ball valve (if installed) or remove the pipe plug near the bottom. Liquid should freely drain from the valve body. If it does not, then the valve is likely in need of cleaning or backflushing.

To clean a GA Industries sewage air release valve equipped with backflushing attachments:

- Close the inlet isolating valve and then slowly open the 1/2" flushing valve to relieve internal pressure.
- Open the 1" blow off valve
- Connect the 1/2" flushing valve to a pressurized source of clean water using the rubber hose provided with the backflushing attachments.
- Introduce flushing water until liquid runs freely from the blow off valve.
- Shut off and disconnect the supply of clean water and close the blow off and flushing valves.
- Slowly open the inlet isolating valve. The air release valve should exhaust air and then close tightly

REPLACEMENT PARTS

Genuine replacement parts are available from your local VAG/GA Industries representative or from the factory:

VAG USA, LLC
 234 Clay Avenue
 Mars, PA 16046 USA
 Telephone: 724-776-1020
 Fax: 724-776-1254
 E-mail: quotes-ga@vag-group.com

Please have the nameplate data available when ordering parts

REPAIR KITS

3" Soft Goods Kit A935-3, Part Number 2-80-11000-020
 4" Soft Goods Kit A935-4, Part Number 2-80-11000-021
 6" Soft Goods Kit A935-6, Part Number 2-80-11000-022

Soft Goods Kit contains Items 6, 7 and 8

Other parts are ordered individually.

WARRANTY

The Warranty for GA Industries valves is included in our Terms and Conditions which can be found here: <https://gaindustries.com/terms>

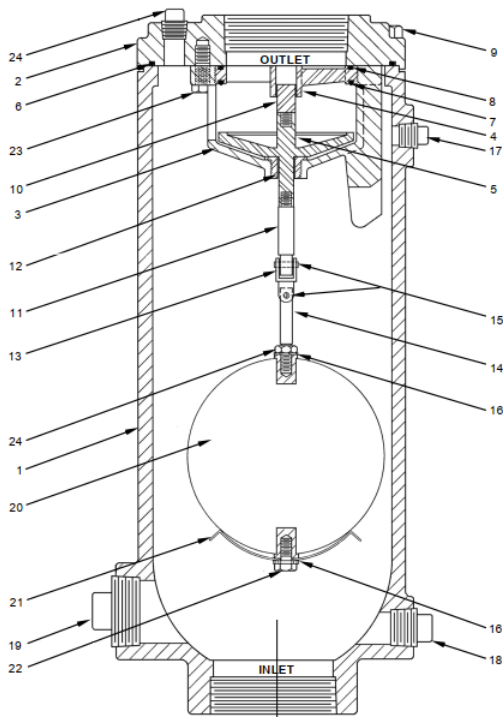

3" and 4" Figure 935

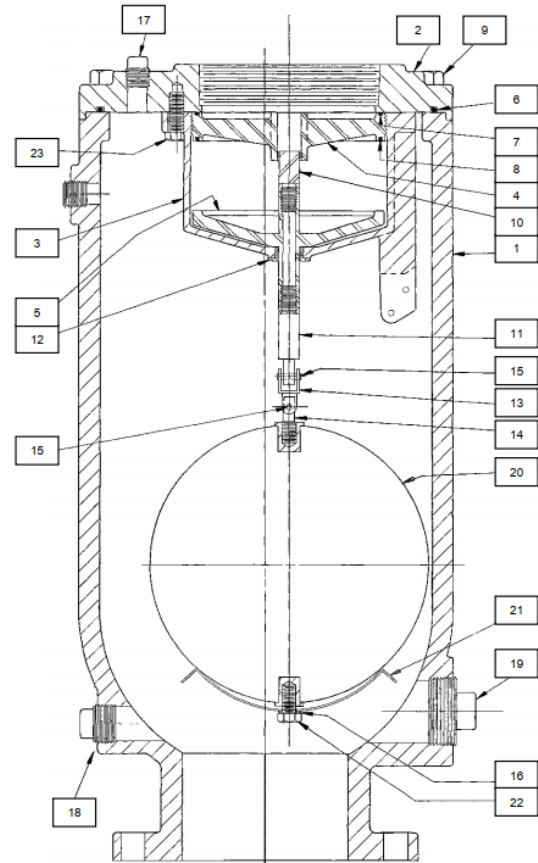

6" Figure 935

PARTS LIST

Item	Description	Item	Description
1.	Body	13.	Universal Coupling
2.	Cover	14.	Float Rod
3.	Cage	15.	Spring Pin
4.	Seat	16.	Lock Washer
5.	Plug	17.	½" Pipe Plug
6.	Cover O-ring	18.	1" Pipe Plug
7.	Renewable Seat	19.	2" Pipe Plug
8.	Cage O-ring	20.	Float Ball
9.	Cover Bolt	21.	Float Hood
10.	Upper Plug Extension	22.	Float Cap Screw
11.	Connector	23.	Cage Bolt
12.	Bushing	24.	Hex Nut

This page intentionally left blank

This page intentionally left blank