

Figures 935-D, 935F-D Sewage Air & Vacuum Valve

Description

GA Industries Figure 935-D Sewage Air & Vacuum Valves efficiently vent air and gas from sewage forcemains as the system is filled and then it close tight once the system is full and pressurized. The valve automatically opens to admit air when the forcemain is drained and/or a negative pressure occurs in the valve.

Figure 935-D are typically installed at system high points where air and sewage gas naturally rise during filling, collect during operation and vacuum first forms during draining. The elongated body is designed to maintain an air gap between the solids bearing fluid and the valve's internal mechanism to minimize fouling and spillage.

Figure 935-DF includes optional "back flushing attachments" to facilitate cleaning sludge and debris from the valve



Product Features

- Full size large orifice for maximum air outflow and inflow rates
- Corrosion resistant Type 316 stainless steel float, plug, seat ring and internal mechanism
- Elongated body reduces potential for fouling
- Tight sealing and easily replaceable rubber seat
- 2" NPT plugged side port allows removal of large debris

Standard Materials

- Body & Cover Cast Iron, ASTM A126 Class B
- Float Stainless Steel, Type 316
- Internal Linkage Stainless Steel, Type 316
- Replaceable Seat Buna-N
- External Fasteners Steel, A307, Zinc Plated
- Coating Internal and External NSF-61 Certified Epoxy

Approvals & Certifications

- Complies with AWWA Standard C512

Options/Accessories

- Option BA Build America/Buy America (BABA) and American Iron and Steel (AIS) Compliant
- Option FA: Backflush Attachments – inlet isolating valve, 1/2" flushing valve, 1" blow off valve, quick connect couplings and 5 ft. rubber hose
- Option IV Inlet Isolating Valve – lever operated AWWA flanged butterfly valve (included with backflush attachments)
- Option OC Outlet cowl
- Option SE 316 stainless steel external fasteners
- Option US American Iron and Steel (AIS) Compliant

Ordering Data

- Figure Number (935-D, 935F-D)
- Size (Inlet x Outlet)
- Options/Accessories

Non-Shock Working Water Pressure at up to 150F (66C)				
	Valve Only		Valve and Backflush Attachments	
Figure Numbers	935-D		935F-D	
Inlet Size	4" Class 125	6" Class 125	4" Class 125	6" Class 125
Outlet Size	4" NPT	6" NPT	4" NPT	6" NPT
Working Pressure	10-200 PSI		10-200 PSI	
Pressure Rating	200 PSI		200 PSI	
Hydro Test	300 PSI		300 PSI	

Data Sheet 935.02G

Pressure at Valve Inlet	Air OUTFLOW Rate, Standard Cubic Feet/Min (SCFM)	
	4"	6"
1 PSI	1208	2436
2 PSI	1762	3554
3 PSI	2222	4481
4 PSI	2637	5318
5 PSI	3027	6103

Value is rate at which air is vented from pipeline/system during filling at valve inlet pressures shown. Inlet pressure during filling should not exceed 2 PSI.

Pressure at Valve Inlet	Air INFLOW Rate, Standard Cubic Feet/Min (SCFM)	
	4"	6"
-1 PSIG	1275	2870
-2 PSIG	1804	4060
-3 PSIG	2210	4972
-4 PSIG	2551	5741
-5 PSIG	2853	6419

Value is rate at which air is drawn into the valve at negative pipeline/system pressure shown.

INSTALLATION DIMENSIONS

SIZE	4"	6"
A (Square)	9½"	13½"
B	25½"	29"
C	5"	5"
D	7⅞"	9⅞"
E	11½"	14¼"
F	30½"	34"
Valve Weight	190 lb.	320 lbs.
Add for Inlet Isolating Valve Only	45 lbs.	70 lbs.
Add for Backflush Attachments	85 lbs.	110 lbs.

With INLET ISOLATING VALVE or BACKFLUSH ATTACHMENTS

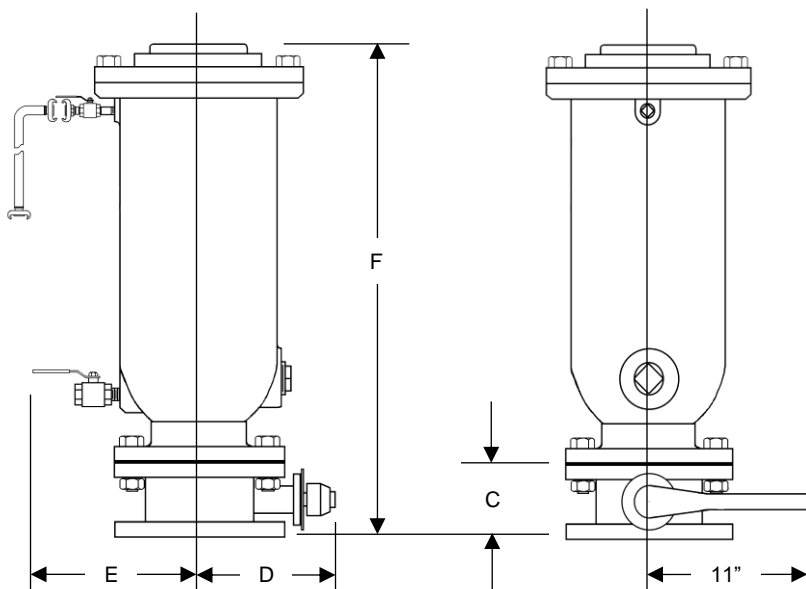

VALVE ONLY

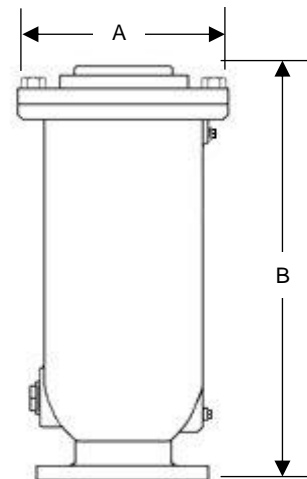

Inlet isolating butterfly valve included with backflush attachments