

Figures 939SS, 939SSF Durovent™ Sewage/Wastewater Air Vacuum Valve Short Body All 316 Stainless Steel Construction

Description

GA Industries Figure 939SS Air & Vacuum Valves efficiently vent air and sewage gas from sewage forcemains as they are being filled and then close tight once the system is full and pressurized. They automatically open to admit air to limit vacuum formation when the forcemain is drained and/or a negative pressure occurs in the valve.

Whether due to the fluid itself or ambient conditions, Durovent® Wastewater Air Release Valves provide the ultimate in corrosion resistance since the body, cover, float, internal linkage, external fasteners and pipe plugs are all made from Type 316 stainless steel.

Figure 939SS Air & Vacuum Valves are typically installed at system high points where air and sewage gas naturally rise during filling and vacuum first forms during draining. The valve's short body allows it to be used in shallow cover installations where a standard elongated body would be too tall.

Figure 939SSF includes optional "back flushing attachments" to facilitate cleaning sludge and debris from the valve



Product Features

- Short body ideal for "shallow cover" installations
- Full size orifice for maximum air outflow and inflow rates
- Rugged, heavy duty cast 316 stainless steel body - no potential for weld corrosion
- Corrosion resistant Type 316 stainless steel float, plug, seat ring and internal mechanism - no plastic components
- Tight sealing and easily replaceable rubber seat
- 2" NPT plugged port allows removal of large debris

Standard Materials

- Body & Cover Stainless Steel, Type 316
- Float Stainless Steel, Type 316
- Internal Linkage Stainless Steel, Type 316
- Replaceable Seat Buna-N
- External Fasteners Stainless Steel, Type 316
- Pipe Plugs Stainless Steel, Type 316

Approvals & Certifications

- Complies with AWWA Standard C512

Options/Accessories

- Option BA Build America/Buy America (BABA) and American Iron and Steel (AIS) Compliant
- Option FA 316SS Backflush Attachments – inlet isolating valve, ½" flushing valve, 1" blow off valve, quick connect couplings and 5 ft. rubber hose
- Option IV Inlet Isolating Valve – lever operated 316SS ball valve (included with backflush attachments)
- Option US American Iron and Steel (AIS) Compliant
- Option VC: Vacuum Check – prevents air re-entry if internal pressure falls below atmospheric

Ordering Data

- Figure Number (939SS, 939SSF)
- Size (Inlet x Outlet)
- Options/Accessories

Non-Shock Working Water Pressure at up to 150F (66C)						
Figure Numbers	939SS Valve Only			939SSF Valve and Backflush Attachments		
Size	2 x 1*	2	3 x 2**	2 x 1*	2	3 x 2**
Inlet	2" NPT	2" NPT	3" NPT	2" NPT	2" NPT	3" NPT
Outlet	1" NPT	2" NPT	2" NPT	1" NPT	2" NPT	2" NPT
Working Pressure	10-200 PSI			10-200 PSI		
Pressure Rating	200 PSI			200 PSI		
Hydro Test	300 PSI			300 PSI		

* 1" Valve with 2" Inlet Connection ** 2" Valve with 3" Inlet Connection

Data Sheet 939SS.01F

Pressure at Valve Inlet	Air Outflow Rate Standard Cubic Feet/Min (SCFM)		
	2" x 1"	2" x 2"	3" x 2"
1 PSI	78	279	279
2 PSI	114	407	407
3 PSI	144	513	513
4 PSI	171	609	609
5 PSI	196	699	699

Value is rate at which air is vented from pipeline/system during filling at valve inlet pressures shown. Inlet pressure during filling should not exceed 2 PSI. Size is inlet x outlet.

Pressure at Valve Inlet	Air Inflow Rate Standard Cubic Feet/Min (SCFM)		
	2" x 1"	2" x 2"	3" x 2"
-1 PSIG	79	318	318
-2 PSIG	112	451	451
-3 PSIG	138	552	552
-4 PSIG	159	637	637
-5 PSIG	178	713	713

Value is rate at which air is drawn into the valve at negative pipeline/system pressure shown. Size is inlet x outlet.

With INLET ISOLATING VALVE or BACKFLUSH ATTACHMENTS

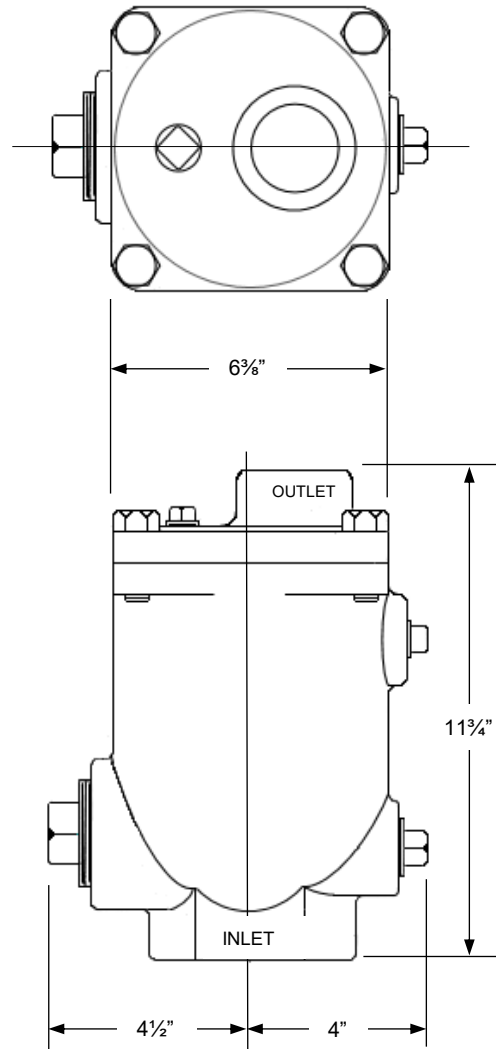
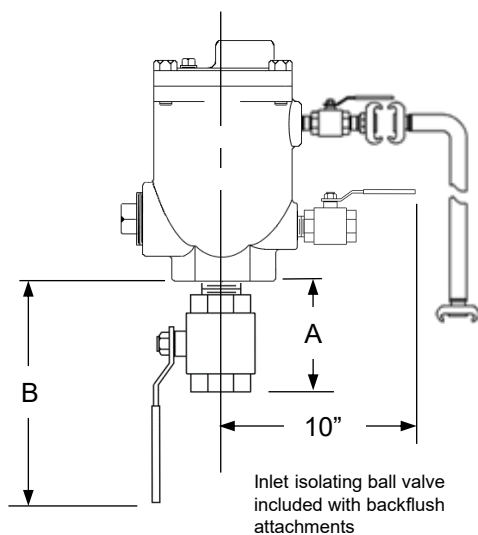

INLET CONNECTION SIZE	2"	3"
A	5"	8"
B	8"	13"
Valve Weight	40 lb.	40 lb.
Add for Inlet Isolating Ball Valve	2 lbs.	20 lbs.
Add for Backflush Attachments	15 lbs.	27 lbs.

All dimensions and weights are approximate. If critical request certified drawings