

INSTALLATION, OPERATION AND MAINTENANCE MANUAL

FIGURE 939SS

2"x1", 2" & 3"x 2"

Durovent™ AIR & VACUUM VALVES FOR SEWAGE & WASTEWATER

TABLE OF CONTENTS

Introduction	2
Description of Operation	2
Receiving & Storage	2
Installation	2
Valve Construction	3
Preventive Maintenance	3
Testing/Trouble Shooting	3
Disassembly	3
Assembly	4
Backflushing Instructions	4
Order Replacement Parts	4
Repair Kits	5
Warranty	5
Figure 939SS Drawing/Parts List	5



234 Clay Avenue • Mars, PA 16046 USA
Telephone (724) 776-1020 • Fax (724) 776-1254
E-mail: info-ga@vag-group.com



WARNING: Cancer and Reproductive Harm – www.Prop65Warnings.ca.gov

INSTALLATION, OPERATION and MAINTENANCE

2"x1", 2" & 3"x 2" Figure 939SS Air & Vacuum Valves

INTRODUCTION

This manual will provide the information to properly install, operate and maintain the valve to ensure a long service life. The Air Release Valve is ruggedly constructed to provide years of trouble-free operation with minimal maintenance.

CAUTION

The valve is NOT recommended for use with toxic fluids, fuels or fluids containing hazardous gases

CAUTION

The valve will not function if used at a pressure higher than the maximum working pressure indicated on the nameplate.

The Shop Order (SO) Number, Figure Number, size and pressure rating are stamped on a nameplate attached to the valve. Please refer to the SO number when ordering parts.

DESCRIPTION OF OPERATION

The Figure 939SS Durovent™ Short Body Air & Vacuum Valve vents air and sewage gas as the system is being filled with fluid. When the system is full, fluid rises in the valve and lifts the float to close the valve. The valve remains closed until the system is drained or a negative pressure occurs within the valve/system. At that time the Figure 935SS automatically opens to admit air to alleviate the vacuum. Figure 939SS Durovent™ Air & Vacuum valves are usually installed at high points in the system where air rises as during filling and vacuum first forms during draining. Its short body facilitates installation when there is "shallow cover."

RECEIVING AND STORAGE

Inspect the valve upon receipt for damage during shipment. Carefully unload all valves to the ground without dropping.

The valves should remain in a clean, dry and weather protected area until installed. For long term storage (greater than 6 months) the rubber

surfaces of the seat should be coated with a non-toxic lubricant such as "SuperLube" made by Synco Chemical. Do not expose the rubber parts to sunlight or ozone.

INSTALLATION

The Figure 939SS is standard with 2" or 3" NPT screwed pipeline connections. A flanged pipeline connection is provided on special order.

Consult the drawings of record to verify the configuration supplied and installed.

The valve must be installed in an upright vertical orientation, normally at a high point in the system.

If installed outdoors, below ground in a vault or in an unheated area, adequate freeze protection must be provided.

An isolating valve should be installed between the valve and the pipeline or system to facilitate maintenance (included with backflushing attachments).

Carefully screw threaded end valves onto pipe nipple using compatible thread sealant. Tighten valve using wrench flats. DO NOT OVER-TIGHTEN.

Flat-faced flanged valves should be mated with flat-faced flanges and full-face gaskets. If ring gaskets are used the bolt material shall be ASTM A307 Grade B (or equivalent). Higher strength bolting should only be used with full-face gaskets.

Lower heavy valves over the mating flange using slings or chains around the valve body. Lubricate the bolts or studs and insert around flange. Lightly tighten bolts until gaps are eliminated. Torque bolts in an alternating pattern in graduated steps. If leakage occurs wait 24 hours and re-torque the bolts but do not compress the gasket more than 50% or exceed bolt maximum torque rating.

VALVE CONSTRUCTION

The standard Figure 939SS Durovent™ Sewage Air & Vacuum Valve has a cast 316 stainless steel body and cover, 316 stainless steel float, plug, seat and internal mechanism and a rubber seat. Refer to the List of Materials submitted for the order if non-standard materials were provided.

Refer to Page 5 for details of construction and parts location.

The Figure 939SS has a 10 to 200 PSI working pressure range.

The valve has an inlet connection at the bottom where the valve attaches to the system and a outlet connection at the top through which air leaves and enters the valve.

WARNING

Removing the valve from the line or disassembling the valve while there is pressure in the valve body may result in injury or damage to the valve

PREVENTIVE MAINTENANCE

Figure 939SS Durovent™ Sewage Air Vacuum Valves require no scheduled lubrication or adjustment.

A periodic visual inspection should be performed to ensure the outlet piping is not obstructed and to verify there is no fluid leakage.

Depending on the nature of the fluid, sewage air valves may become clogged with sediment or grease and require periodic cleaning. To facilitate such cleaning GA Industries air valves with an “F” at the end of the Figure Number (e.g., 939SSF) were supplied with “backflushing attachments.” Refer to the backflushing instructions on Page 4 of this manual for additional information.

TESTING

Valve operation can be easily tested. Close the inlet isolation valve and remove or loosen the pipe plug nearest the inlet to drain the water from the valve. The float should drop as the water leaves the valve. NOTE: A manual valve can be installed in place of the pipe plug to facilitate testing (valves are included with backflushing attachments).

Replace or tighten the pipe plug and slowly open the inlet isolating valve. After expelling air, the valve should close and seal tightly.

TROUBLESHOOTING

- Valve Does Not Close / Fluid Leakage

Verify debris has not collected on the seat preventing tight closure

Verify rubber seat and/or seating surfaces are not damaged

Verify float has buoyancy

Verify internal mechanism operates freely without binding or sticking

Verify the pressure at the valve inlet it at least 10 PSI

- Valve Does Not Open

Verify debris in the valve is not preventing the float from freely falling when fluid is drained from valve

Verify internal mechanism operates freely without binding or sticking

DISASSEMBLY

While small valves may be more easily serviced by removing it from the line, all valves can be serviced while the body remains connected to the pipeline. A skilled technician with proper tools should perform all work. No special tools are required.

Disassemble the valve only as far as needed to replace damaged or worn parts.

First ensure there is no pressure within the valve. Remove the cover bolts (11) and lift off cover (2) with internal mechanism attached. It may be necessary to pry the cover off. Be careful not to damage or lose the O-ring (8) unless it's being replaced.

Using a chain or strap wrench, unscrew the cage (3) from the cover (2) being careful not to lose the seat O-ring (10) unless it's being replaced.

Unscrew float ball (12) from float rod (9). It may be necessary to apply heat as these parts are secured with Loctite.

Unscrew the seat (4) from the cage (3) being careful not to lose the renewable seat (9) unless it's being replaced. Remove the plug (5) with connector (7) attached and the bushing (6). Note: Bushing is only supplied in older valves with ductile iron cage.

Unscrew the connector (7) from the plug (5). It may be necessary to apply heat as these parts are secured with Loctite.

Remove the float screw (13), lock washer (18) and float hood (17) from the float ball (12). Apply heat if necessary.

Inspect all parts for wear and damage. Minor scratches and dents in the float are normal. Some floats may contain sand for added weight but if water is detected replace the float. Carefully clean the orifice of scale. Replace damaged parts.

REASSEMBLY

Clean all parts especially seating and sealing surfaces before reassembling valve. Worn parts should be replaced during re-assembly.

Apply Loctite 263 to threads on one end of connector (7), install in plug (5) and tighten. Install bushing (if needed) in cage.

Lubricate and install renewable seat (9) in plug and drop plug into cage (3). Install seat (4) over the plug stem, thread into cage and tighten.

Apply Loctite 263 to exposed threads on connector (7), screw on the float ball (12) and tighten.

Lubricate and place seat O-ring (10) in seat (4), install in cover (2) and tighten.

Ensure mechanism operates freely when float ball is lifted and allowed to drop.

Apply Loctite 380 to threads on float screw (13) and install float screw, lock washer (18) and float hood (17) on bottom of float ball (12).

Lubricate cover O-ring (13) in cover (2) and install on body (1) ensuring O-ring is retained. Install the cover bolts (11) and tighten in an alternating pattern.

Carefully introduce pressure and check for leaks.

BACKFLUSHING INSTRUCTIONS

Follow all local cross-connection and safety codes and regulations!

To determine if a GA Industries sewage air valve needs cleaning or backflushing:

- Close the inlet isolating valve then slowly open the ½" flushing ball valve (if installed) or slowly remove the pipe plug at the top of air valve to relieve internal pressure.
- Open the 1" blow off ball valve (if installed) or remove the pipe plug near the bottom. Liquid should freely drain from the valve body. If it does not, then the valve is likely in need of cleaning or backflushing.

To clean a GA Industries sewage air release valve equipped with backflushing attachments:

- Close the inlet isolating valve and then slowly open the ½" flushing valve to relieve internal pressure.
- Open the 1" blow off valve
- Connect the ½" flushing valve to a pressurized source of clean water using the rubber hose provided with the backflushing attachments.
- Introduce flushing water until liquid runs freely from the blow off valve.
- Shut off and disconnect the supply of clean water and close the blow off and flushing valves.
- Slowly open the inlet isolating valve. The air release valve should exhaust air and then close tightly

REPLACEMENT PARTS

Genuine replacement parts are available from your local VAG/GA Industries representative or from the factory:

VAG USA, LLC
234 Clay Avenue
Mars, PA 16046 USA
Telephone: 724-776-1020
Fax: 724-776-1254
E-mail: quotes-ga@vag-group.com

Please have the nameplate data available when ordering parts.

WARRANTY

The Warranty for GA Industries valves is included in our Terms and Conditions which can be found here: <https://gaindustries.com/terms>

REPAIR KITS

Soft Goods Kit A939 (Part Number 2-80-11000-023) contains Items 8, 9 and 10

Other parts are ordered individually.

2"x1", 2" and 3" x 2" Figure 939SS Parts List

Item	Description	Standard Material
1	Body	316 Stainless Steel
2	Cover	316 Stainless Steel
3	Cage	316 Stainless Steel
4	Seat	316 Stainless Steel
5	Plug	316 Stainless Steel
6	Bushing	316 Stainless Steel
7	Connector	316 Stainless Steel
8	Cover O-Ring	Buna-N Rubber
9	Renewable Seat	Buna-N Rubber
10	Seat O-Ring	Buna-N Rubber
11	Cover Bolt	316 Stainless Steel
12	Float Ball	316 Stainless Steel
13	Float Screw	Nylon
14	½" Pipe Plug	316 Stainless Steel
15	1" Pipe Plug	316 Stainless Steel
16	2" Pipe Plug	316 Stainless Steel
17	Float Hood	316 Stainless Steel
18	Lock Washer	410 Stainless Steel

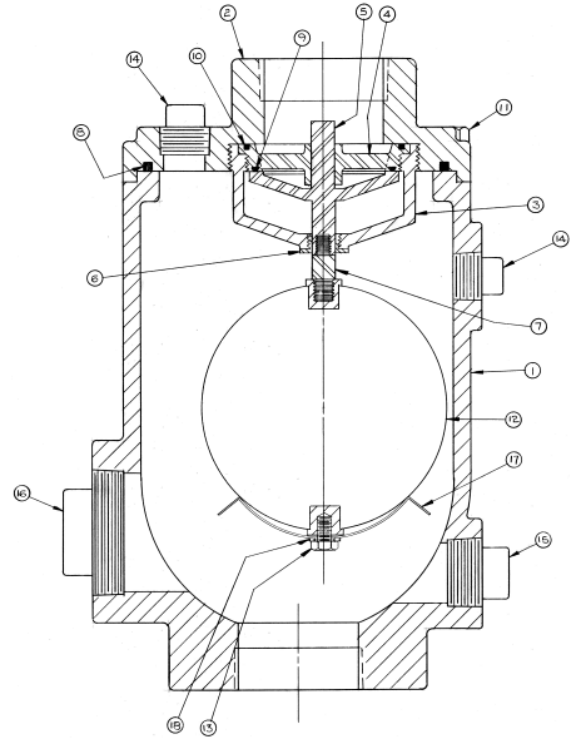

VAG USA, LLC

234 Clay Avenue • Mars, PA 16046 USA
Phone: 724-776-1020 • Fax: 724-776-1020

info-ga@vag-group.com

www.gaindustries.com