

Figure 950-D, 950H-U Dual Body Combination Air Valves for Clean Water

Description

GA Industries Figures 950-D and 950H-U Combination Air Valves are “triple function” valves and consist of an air release valve factory piped to an air & vacuum valve. They vent air from pipelines and systems as they are being filled with water and then close tight once the system is full and pressurized. They also release air that accumulates in the valve while the system is operational. And they automatically open to admit air to limit vacuum formation when the pipeline or system is drained and/or a negative pressure occurs in the valve.

The 4” Figure 950-D and 950H-U are standard with NPT outlet while 6” to 12:” are standard with an outlet cowl.

Product Features

- Compact and light weight
- Full port orifice for maximum air outflow and inflow
- Utilizes “kinetic” operating principle, designed not to blow shut
- Rugged cast iron body and cover
- Corrosion resistant Type 316 stainless steel float
- Tight sealing and easily replaceable rubber seats

Standard Materials

- Bodies & Covers Cast Iron, ASTM A126 Class B
- Floats Stainless Steel, Type 316
- Internal Linkage Stainless Steel, Type 316
- Replaceable Seat Buna-N Rubber
- External Fasteners Steel, A307, Zinc Plated
- Coating Internal and external NSF-61 certified epoxy

Non-Shock Working Water Pressure at up to 150F (66C)				
Inlet Size	4”	6” to 12”	4”	6” to 12”
Figure Number	950-DT	950-DC	950H-UT	950H-UC
Inlet Connection	ANSI Class 125		ANSI Class 250	
Outlet Size	Same as Inlet		Same as Inlet	
Standard Outlet	NPT	Cowl	NPT	Cowl
Air Release Orifice Diameter	0.094”	0.188”	0.063”	0.125”
Working Pressure	10 – 150 PSI		10 – 300 PSI	
Pressure Rating	200 PSI		300 PSI	
Hydro Test	300 PSI		450 PSI	



Approvals & Certifications

- Complies with AWWA Standard C512
- NSF-61 Certified for Contact with Drinking Water
- NSF-372 Certified Lead Free

Options/Accessories

- Option BA Build America/Buy America (BABA) and American Iron and Steel (AIS) Compliant
- Option IV Inlet Isolating Valve, 4” and 6” lever operated, 8” and larger worm gear operated AWWA butterfly valve (Figures 950-DT and 950-DC only)
- Option FO Flanged Outlet – ANSI Class 125 flanged outlet connection (6” to 12” Only)
- Option SE 316 Stainless Steel external fasteners
- Option US American Iron and Steel (AIS) Compliant

Ordering Data

- Figure Number (950-DT, 950-DC, 950H-UT, 950H-UC)
- Size
- Options/Accessories

Data Sheet 950.01F

Air Vacuum Orifice

Pressure at Valve Inlet During Filling	Air Outflow Rate, Standard Cubic Feet/Min (SCFM)				
	4"	6"	8"	10"	12"
1 PSI	1260	2830	5030	7850	11300
2 PSI	1780	4000	7110	11100	16000
3 PSI	2180	4900	8710	13600	19600
4 PSI	2510	5660	10100	15700	22600
5 PSI	2810	6320	11200	17600	25300
7 PSI	3320	7480	13300	20800	29900
10 PSI	3970	8940	15900	24800	35800
15 PSI	4870	11000	19500	30400	43800

Value is rate at which air is vented from pipeline/system during filling at valve inlet pressures shown. Inlet pressure during filling should not exceed 5 PSI.

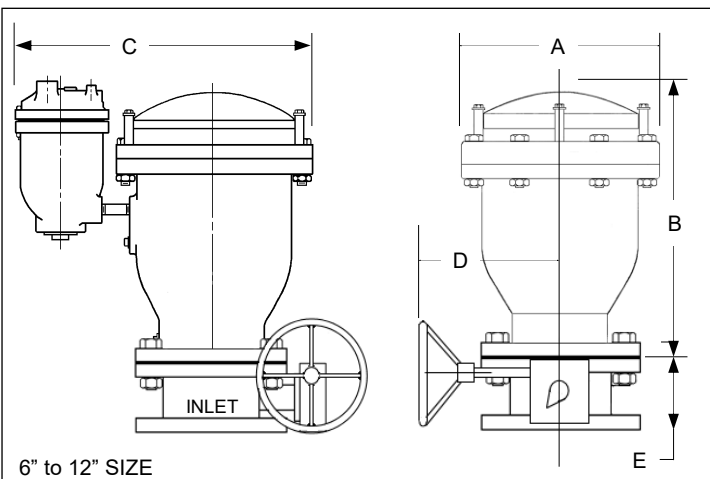
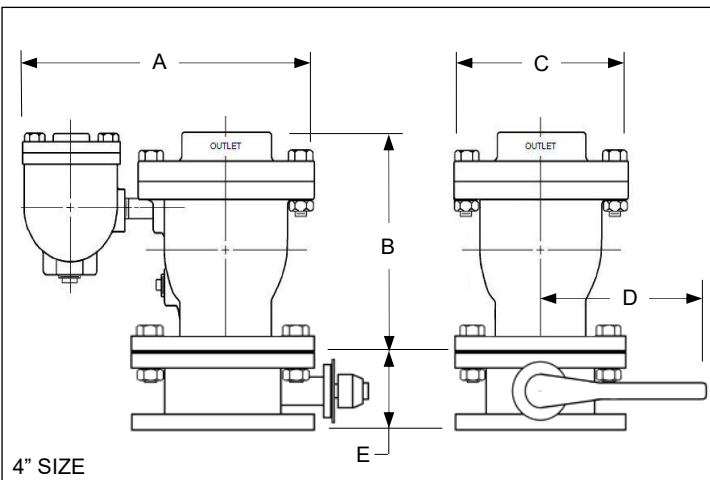

Air Vacuum Orifice

Pressure at Valve Inlet During Draining	Air Inflow Rate, Standard Cubic Feet/Min (SCFM)				
	4"	6"	8"	10"	12"
-1 PSIG	1280	2880	5130	8010	11600
-2 PSIG	1810	4080	7250	11300	16400
-3 PSIG	2220	5000	8880	13900	20000
-4 PSIG	2560	5770	10300	16000	23100
-5 PSIG	2870	6430	11500	17900	25900

Value is rate at which air is drawn into the valve at negative pipeline/system pressure shown. Multiply SCFM air inflow rate x 7.48 to convert to equivalent pipeline/system liquid draining rate in USGPM.

Air Release Orifice

Pressure At Valve Inlet	Air Release Orifice Venting Rate, Standard Cubic Feet/Min (SCFM)			
	Figure 950-DT	Figure 950-DC	Figure 950H-UT	Figure 950H-UC
	4"	6" to 12"	4"	6" to 12"
10 PSI	2.2	3.9	1.0	2.2
15 PSI	2.6	4.7	1.2	2.6
25 PSI	3.5	6.3	1.6	3.5
50 PSI	5.8	10.3	2.6	5.8
75 PSI	8.0	14.2	3.6	8.0
100 PSI	10.2	18.2	4.5	10.2
150 PSI	14.7	26.1	6.5	14.7
200 PSI			8.5	19.1
250 PSI			10.5	23.6
300 PSI			12.5	28.0

Installation Dimensions

SIZE	4"	6"	8"	10"	12"	
A	8¼	15¼	19	23½	27½	
B	12¾	20¾	25¼	33	39¾	
C	12	21¾	25¾	29¾	33¾	
D	8	9	9	9¼	9¼	
E	5	5	6	8	8	
Valve Weight	CL125	90	200	360	500	650
	CL250	100	220	395	555	730
Add for Inlet Isolating Class 125 Butterfly Valve	45	70	135	179	256	

- Dimensions in inches, weight in pounds.
- Inlet isolating butterfly valve is lever operated 4" and 6", worm gear with handwheel 8" to 12". Inlet isolating butterfly valve not available for Class 250 flange air valves.
- All dimensions and weights are approximate. If critical request certified drawings