

Figures 950-T, 950H-T Dual Body, NPT Combination Air Valves for Clean Water

Description

GA Industries Figures 950-T and 950H-T Combination Air Valves are “triple function” valves and consist of an air release valve factory piped to an air & vacuum valve. They vent air from pipelines and systems as they are being filled with water and then close tight once the system is full and pressurized. They also release air that accumulates in the valve while the system is operational. And they automatically open to admit air to limit vacuum formation when the pipeline or system is drained and/or a negative pressure occurs in the valve.

The Figure 950-T and 950H-T are standard with NPT inlet and outlet connections.

Product Features

- Compact and light weight
- Full port large orifice for maximum air outflow and inflow
- Utilizes “kinetic” operating principle, designed not to blow shut
- Rugged cast iron construction
- Corrosion resistant Type 316 stainless steel floats
- Tight sealing and easily replaceable rubber seats

Standard Materials

- Bodies & Covers Cast Iron, ASTM A126 Class B
- Floats Stainless Steel, Type 316
- Internal Linkage Stainless Steel, Type 316
- Replaceable Seat Buna-N Rubber
- External Fasteners Steel, A307, Zinc Plated
- Coating Internal and external BSF-61 Certified Epoxy



Approvals & Certifications

- Complies with AWWA Standard C512

Options/Accessories

- Option BA Build America/Buy America (BABA) and American Iron and Steel (AIS) Compliant
- Option IV with Inlet Isolating Valve, full port, lead free bronze lever operated ball valve
- Option OC with Outlet Cowl
- Option SE 316 Stainless Steel external fasteners
- Option TD with Double Acting Throttle Device
- Option US American Iron and Steel (AIS) Compliant

Ordering Data

- Figure Number (950-T, 950H-T)
- Size
- Options/Accessories

Non-Shock Working Water Pressure at up to 150F (66C)		
Inlet Size	1/2", 3/4", 1", 2" and 3"	1/2", 3/4", 1", 2" and 3"
Figure Number	950-T	950H-T
Inlet Connection	NPT	NPT
Outlet Size	Same as Inlet	Same as Inlet
Standard Outlet	NPT	NPT
Air Release Orifice Diameter	0.094"	0.063"
Working Pressure	10 – 150 PSI	10 – 200 PSI
Pressure Rating	200 PSI	200 PSI
Hydro Test	300 PSI	300 PSI

1/2" and 3/4" are 1" supplied with reducing bushings

Data Sheet 950.02E

Air Vacuum Orifice

Pressure at Valve Inlet During Filling	Air Outflow Rate, Standard Cubic Feet/Min (SCFM)				
	1/2"	3/4"	1"	2"	3"
1 PSI	19.6	44.2	78.5	314	707
2 PSI	27.8	62.5	111	444	1000
3 PSI	34.0	76.5	136	544	1220
4 PSI	39.3	88.4	157	628	1410
5 PSI	43.9	98.8	176	703	1580
7 PSI	52.0	117	208	831	1870
10 PSI	62.1	140	248	994	2240
15 PSI	75.2	169	304	1217	2740

Value is rate at which air is vented from pipeline/system during filling at valve inlet pressures shown. Inlet pressure during filling should not exceed 5 PSI.

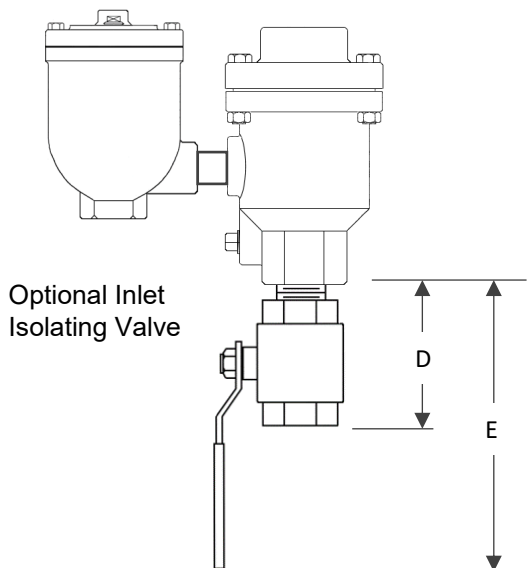
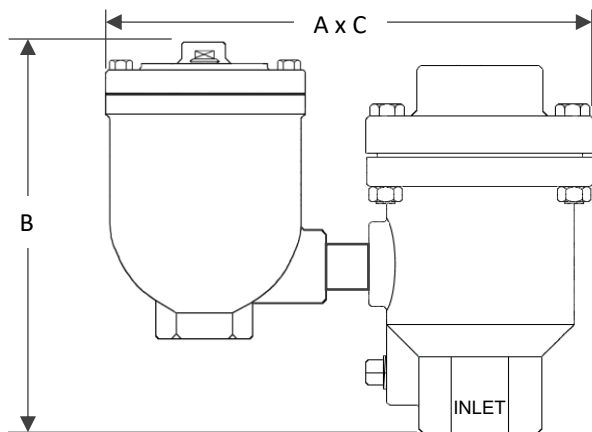

Air Vacuum Orifice

Pressure at Valve Inlet During Draining	Air Inflow Rate, Standard Cubic Feet/Min (SCFM)				
	1/2"	3/4"	1"	2"	3"
-1 PSIG	20.0	45.2	80	320	721
-2 PSIG	28.3	63.9	113	453	1020
-3 PSIG	34.7	78.3	138	555	1250
-4 PSIG	40.1	90.4	160	641	1440
-5 PSIG	44.9	101	179	716	1610

Value is rate at which air is drawn into the valve at negative pipeline/system pressure shown. Multiply SCFM air inflow rate x 7.48 to convert to equivalent pipeline/system liquid draining rate in USGPM.

Air Release Orifice

Pressure At Valve Inlet	Air Release Orifice Venting Rate, Standard Cubic Feet/Min (SCFM)	
	Figure 950-T	Figure 950H-T
	1/2" to 3"	1/2" to 3"
10 PSI	2.2	1.0
15 PSI	2.6	1.2
25 PSI	3.5	1.6
50 PSI	5.8	2.6
75 PSI	8.0	3.6
100 PSI	10.2	4.5
150 PSI	14.7	6.5
200 PSI		8.5

Installation Dimensions

SIZE	1/2"	3/4"	1"	2"	3"
A	7%	7%	7%	9%	10½
B	7%	7%	7%	9	10%
C	4	4	4	5%	6%
D	4	4	4	5	8
E	9¼	9¼	9¼	11¼	13½
Valve Weight	15	15	15	25	45
Add for Inlet Isolating Ball Valve	2	2	2	8	20

- Dimensions in inches, weight in pounds.
- Inlet isolating valve is lever operated bronze ball valve
- All dimensions and weights are approximate. If critical request certified drawings