

Figures 957-D, 957-DF Dual Body Sewage Combination Air Valve

Description

GA Industries Figure 957-D Combination Air Valves consist of a Figure 935 Sewage Air & Vacuum Valve assembled with a Figure 927 High-Capacity Sewage Air Release Valve. Air is vented through the Figure 935's large orifice as the system is filled and then it close tight once the system is full and pressurized. Residual air and gas is released through the Figure 927's small orifice while the system is in operation. The large orifice automatically opens to admit air when the forcemain is drained and/or a negative pressure occurs in the valve.

Figure 957-D are typically installed at system high points where air and sewage gas naturally rise during filling, collect during operation and vacuum first forms during draining. The elongated body is designed to maintain an air gap between the solids bearing fluid and the valve's internal mechanism to minimize fouling and spillage.

Figure 957-DF includes optional "back flushing attachments" to facilitate cleaning sludge and debris from the valve



Product Features

- Full size large orifice for maximum air outflow and inflow rates
- Exceptionally large small orifice for efficient release of residual air and gas
- Corrosion resistant Type 316 stainless steel float, plug, seat ring and internal mechanism
- Elongated bodies reduce potential for fouling
- Tight sealing and easily replaceable rubber seats

Standard Materials

- Bodies & Covers Cast Iron, ASTM A126 Class B
- Floats Stainless Steel, Type 316
- Internal Linkages Stainless Steel, Type 316
- Replaceable Seats Buna-N
- External Fasteners Steel, A307, Zinc Plated
- Coating Internal and external NSF-61 certified epoxy

Approvals & Certifications

- Complies with AWWA Standard C512

Options/Accessories

- Option BA Build America/Buy America (BABA) and American Iron and Steel (AIS) Compliant
- Option IV Inlet Isolating Valve – lever operated flanged butterfly valve. Note: inlet valve included with backflush attachments.
- Option SE 316 Stainless Steel external fasteners
- Option US American Iron and Steel (AIS) Compliant

Ordering Data

- Figure Number (957-D, 957-DF)
- Size (Inlet x Outlet)
- Options/Accessories

Non-Shock Working Water Pressure at up to 150F (66C)									
Figure Numbers	Valve Only				Valve and Backflush Attachments				
	957-DL		957-D		957-DLF		957-DF		
Inlet Size	4" Class 125	6" Class 125	4" Class 125	6" Class 125	4" Class 125	6" Class 125	4" Class 125	6" Class 125	
Outlet Size	4" NPT	6" NPT	4" NPT	6" NPT	4" NPT	6" NPT	4" NPT	6" NPT	
Air Release Orifice Dia.	0.500"		0.438"		0.500"		0.438"		
Working Pressure	10-75 PSI		10-150 PSI		10-75 PSI		10-150 PSI		
Pressure Rating	200 PSI								
Hydro Test	300 PSI								

Data Sheet 957.02G

Air Vacuum Orifice

Pressure at Valve Inlet	Air OUTFLOW Rate, Standard Cubic Feet/Min (SCFM)	
	4"	6"
1 PSI	1208	2436
2 PSI	1762	3554
3 PSI	2222	4481
4 PSI	2637	5318
5 PSI	3027	6103

Value is rate at which air is vented from pipeline/system during filling at valve inlet pressures shown. Inlet pressure during filling should not exceed 2 PSI.

Air Release Orifice

Pressure At Valve Inlet	Air Release Orifice Venting Rate, Standard Cubic Feet/Min (SCFM)	
	957-DL,957-DLF	957-D, 957-DF
10 PSI	62.1	47.5
15 PSI	76.1	58.2
25 PSI	100.6	77.0
50 PSI	163.9	125.5
75 PSI	227.3	174.0
100 PSI		222.5
150 PSI		319.5

VALVE ONLY

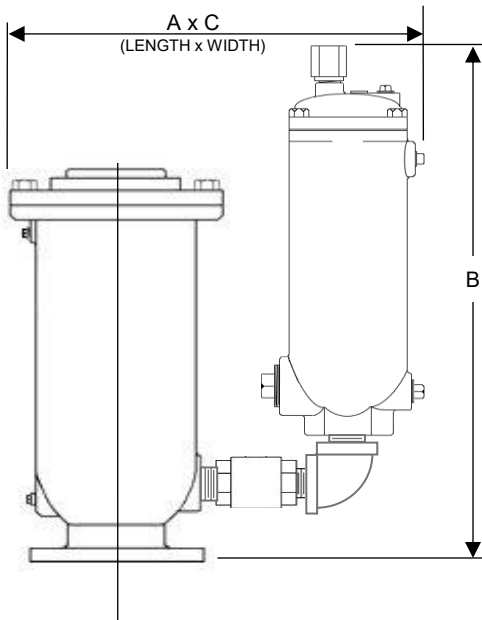

Air Vacuum Orifice

Pressure at Valve Inlet	Air INFLOW Rate, Standard Cubic Feet/Min (SCFM)	
	4"	6"
-1 PSIG	1275	2870
-2 PSIG	1804	4060
-3 PSIG	2210	4972
-4 PSIG	2551	5741
-5 PSIG	2853	6419

Value is rate at which air is drawn into the valve at negative pipeline/system pressure shown.

Installation Dimensions

SIZE	4"	6"
A	17"	22"
B	33"	35"
C	9½"	13½"
D	22¾"	25¼"
Valve Weight	260 lb.	390 lbs.
Add for Inlet Isolating Valve Only	45 lbs.	70 lbs.
Add for Backflush Attachments	85 lbs.	110 lbs.

Dimensions and weights are approximate, request certified drawings if critical.

With INLET ISOLATING VALVE or BACKFLUSH ATTACHMENTS

