

Figure 960-D, 960H-U Single Body Combination Air Valves for Clean Water

Description

GA Industries Figures 960-D and 960-U Combination Air Valves are dual chamber “triple function” valves providing the functions of an air release valve plus that of an air & vacuum valve. They vent air from pipelines and systems as they are being filled with water and then close tight once the system is full and pressurized. They also release air that accumulates in the valve while the system is operational. And, they automatically open to admit air to limit vacuum formation when the pipeline or system is drained and/or a negative pressure occurs in the valve.

The Figure 960-D and 960-U are standard with an outlet cowl with optional Class 125 flanged outlet connection.



Product Features

- Full port orifice for maximum air outflow and inflow
- Utilizes “kinetic” operating principle, designed not to blow shut
- Rugged cast iron body and cover
- Corrosion resistant Type 316 stainless steel float
- Tight sealing and easily replaceable rubber seats

Standard Materials

- Bodies & Covers Cast Iron, ASTM A126 Class B
- Floats Stainless Steel, Type 316
- Internal Linkage Stainless Steel, Type 316
- Replaceable Seat Buna-N Rubber
- External Fasteners Steel, A307, Zinc Plated
- Coating Internal and External NSF-61 Certified Epoxy

Approvals & Certifications

- Complies with AWWA Standard C512
- NSF-61 Certified for Contact with Drinking Water
- NSF-372 Certified Lead Free

Options/Accessories

- Option BA Build America/Buy America (BABA) and American Iron and Steel (AIS) Compliant
- Option IV Inlet Isolating Valve 6” lever operated, 8” and 10” worm gear operated AWWA Class 125 butterfly valve
- Option FO Flanged Outlet – ANSI Class 125 flanged outlet connection
- Option SE 316 Stainless Steel external fasteners
- Option US American Iron and Steel (AIS) Compliant

Ordering Data

- Figure Number (960-DC, 960-UJ, 960H-UC, 960H-UJ)
- Size
- Options/Accessories

Non-Shock Working Water Pressure at up to 150F (66C)				
Inlet Size	6” to 12”		6” to 12”	
Figure Number	960-DC	960-DJ	960H-UT	960H-UC
Inlet Connection	ANSI Class 125		ANSI Class 250	
Outlet Size	Same as Inlet		Same as Inlet	
Outlet	Cowl	CL125 Flange	Cowl	CL125 Flange
Air Release Orifice Diameter	0.188”		0.125”	
Working Pressure	10 – 150 PSI		10 – 300 PSI	
Pressure Rating	200 PSI		300 PSI	
Hydro Test	300 PSI		450 PSI	

Data Sheet 960.01F

Air Vacuum Orifice

Pressure at Valve Inlet During Filling	Air Outflow Rate, Standard Cubic Feet/Min (SCFM)			
	6"	8"	10"	12"
1 PSI	2830	5030	7850	11300
2 PSI	4000	7110	11100	16000
3 PSI	4900	8710	13600	19600
4 PSI	5660	10100	15700	22600
5 PSI	6320	11200	17600	25300
7 PSI	7480	13300	20800	29900
10 PSI	8940	15900	24800	35800
15 PSI	11000	19500	30400	43800

Value is rate at which air is vented from pipeline/system during filling at valve inlet pressures shown. Inlet pressure during filling should not exceed 5 PSI.

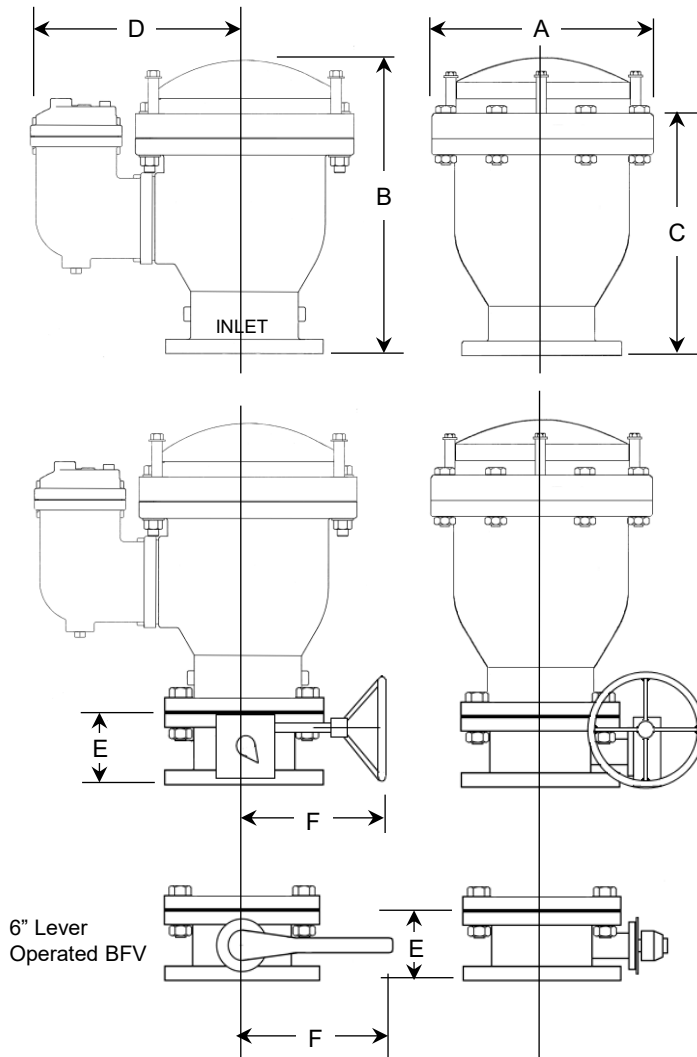

Air Vacuum Orifice

Pressure at Valve Inlet During Draining	Air Inflow Rate, Standard Cubic Feet/Min (SCFM)			
	6"	8"	10"	12"
-1 PSIG	2880	5130	8010	11600
-2 PSIG	4080	7250	11300	16400
-3 PSIG	5000	8880	13900	20000
-4 PSIG	5770	10300	16000	23100
-5 PSIG	6430	11500	17900	25900

Value is rate at which air is drawn into the valve at negative pipeline/system pressure shown. Multiply SCFM air inflow rate x 7.48 to convert to equivalent pipeline/system liquid draining rate in USGPM.

Air Release Orifice

Pressure At Valve Inlet	Air Release Orifice Venting Rate, Standard Cubic Feet/Min (SCFM)	
	Figure 950-D	Figure 950U-H
10 PSI	3.9	2.2
15 PSI	4.7	2.6
25 PSI	6.3	3.5
50 PSI	10.3	5.8
75 PSI	14.2	8.0
100 PSI	18.2	10.2
150 PSI	26.1	14.7
200 PSI		19.1
250 PSI		23.6
300 PSI		28.0

Installation Dimensions

SIZE	6"	8"	10"	12"
A	15¼	19	23½	27½
B	21	25½	33	39½
C (Flanged Outlet)	18	20½	27	32½
D	15	17	19	21
E	5	6	8	8
F	8	9	9¼	9¼
Valve Weight	CL125	225	385	525
	CL250	245	435	560
Add for Inlet Isolating Butterfly Valve	66	132	190	256

- Inlet isolating butterfly valve is lever operated in 6" size, worm gear with handwheel in 8" to 12" size. Available for Class 125 Figure 960-D only.
- Dimensions in inches, weight in pounds.
- All dimensions and weights are approximate. If critical request certified drawings