

# Figure 980-DC, 980-DJ Single Body Slow Closing Combination Air Valves for Clean Water

## Description

GA Industries Figures 980-DC and 980-DJ consist of a Figure 960-D Combination Air Valve and Figure F284-D Surge Check, valve factory assembled and tested as a unit. This valve system vents air during filling, admits air during draining and releases residual air during operation. Plus, the surge check's adjustable regulated exhaust feature minimizes surges and protects the air valve from damage by controlling the rate at which air is vented as the system re-pressurizes after a column separation.

GA Industries Figure 983-D/983-U Slow Closing Combination Air Valves are typically installed at system high points where air naturally rises, and column separation is likely to occur.

The Figure 980-DC has an outlet cowl while the 980-DJ has a Class 125 flanged outlet.

## Product Features

- Full port orifice for maximum air outflow and inflow
- Utilizes "kinetic" operating principle, designed not to blow shut
- Surge check reduces air venting rate to minimize surge and protect air valve
- Rugged cast iron body and cover
- Corrosion resistant Type 316 stainless steel float
- Tight sealing and easily replaceable rubber seats

## Air Valve Standard Materials

- Body & Cover Cast Iron, ASTM A126 Class B
- Float Stainless Steel, Type 316
- Replaceable Seat Buna-N
- External Fasteners Steel, A307, Zinc Plated
- Coating Internal and External NSF-61 Certified Epoxy

## Surge Check Standard Materials

- Body Ductile Iron, ASTM A536 Gr 65-45-12
- Trim Lead-Free Bronze
- Coating NSF-61 Certified Fusion Bond Epoxy

Non-Shock Working Water Pressure at up to 150F (66C)	
Inlet Size	6" to 12"
Figure Number	980-DC      980-DJ
Inlet Connection	ANSI Class 125
Outlet Size	Same as Inlet
Outlet	Cowl      CL125 Flange
Air Release Orifice Diameter	0.188"
Working Pressure	10 – 150 PSI
Pressure Rating	200 PSI
Hydro Test	300 PSI



## Approvals & Certifications

- Complies with AWWA Standard C512

## Options/Accessories

- Option IV Inlet Isolating Valve 6" lever operated, 8" and 10" worm gear operated AWWA Class 125 butterfly valve
- Option FO Flanged Outlet – ANSI Class 125 flanged outlet connection
- Option SE 316 Stainless Steel external fasteners
- Option US American Iron and Steel (AIS) Compliant

## Ordering Data

- Figure Number (980-DC, 980-DJ)
- Size
- Options/Accessories

## Data Sheet 980.01G

### Air Vacuum Orifice

Pressure at Valve Inlet During Filling	Air Outflow Rate, Standard Cubic Feet/Min (SCFM)			
	6"	8"	10"	12"
1 PSI	2830	5030	7850	11300
2 PSI	4000	7110	11100	16000
3 PSI	4900	8710	13600	19600
4 PSI	5660	10100	15700	22600
5 PSI	6320	11200	17600	25300
7 PSI	7480	13300	20800	29900
10 PSI	8940	15900	24800	35800
15 PSI	11000	19500	30400	43800

Value is rate at which air is vented from pipeline/system during filling at valve inlet pressures shown. Inlet pressure during filling should not exceed 5 PSI.

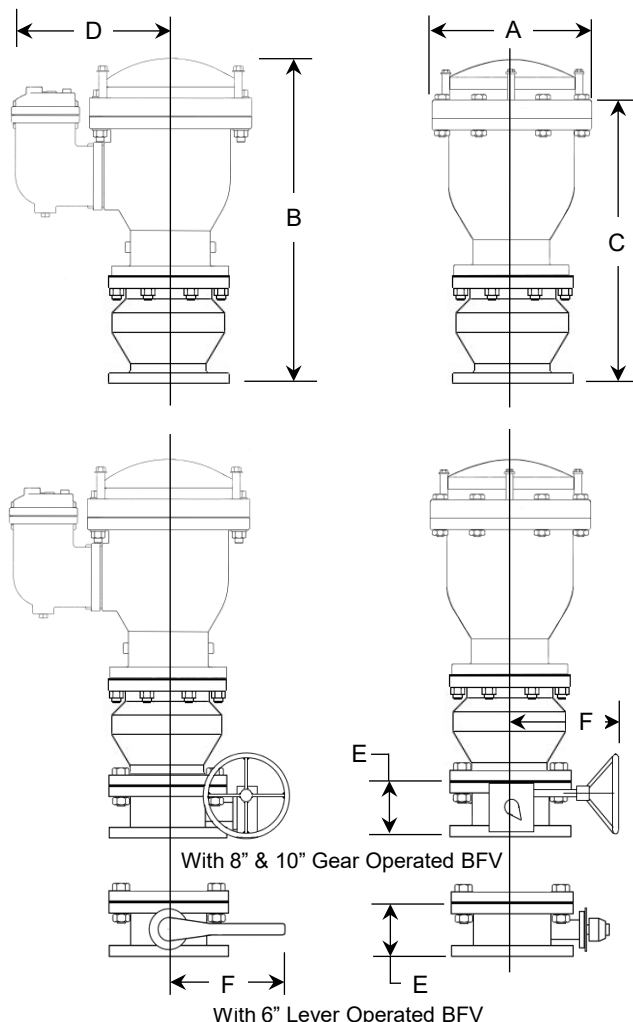

### Air Vacuum Orifice

Pressure at Valve Inlet During Draining	Air Inflow Rate, Standard Cubic Feet/Min (SCFM)			
	6"	8"	10"	12"
-1 PSIG	2880	5130	8010	11600
-2 PSIG	4080	7250	11300	16400
-3 PSIG	5000	8880	13900	20000
-4 PSIG	5770	10300	16000	23100
-5 PSIG	6430	11500	17900	25900

Value is rate at which air is drawn into the valve at negative pipeline/system pressure shown. Multiply SCFM air inflow rate x 7.48 to convert to equivalent pipeline/system liquid draining rate in USGPM.

### Air Release Orifice

Pressure At Valve Inlet	Air Release Orifice Venting Rate, Standard Cubic Feet/Min (SCFM)
	Figure 980-D
10 PSI	3.9
15 PSI	4.7
25 PSI	6.3
50 PSI	10.3
75 PSI	14.2
100 PSI	18.2
150 PSI	26.1

### Installation Dimensions

SIZE	6"	8"	10"	12"	
A (Diameter)	15¼	19	23½	27½	
B	30¾	37¾	48¾	54¾	
C (Flanged Outlet)	27¾	33¾	41	48	
D	15	17	19	21	
E	5	6	8	8	
F	8	9	9¼	9¼	
Valve Weight	CL125	300	510	730	1030
Add for Inlet Isolating CL125 Butterfly Valve. Lbs.	66	132	190	Not Available	

- Inlet isolating butterfly valve is lever operated in 6" size, worm gear with handwheel in 8" to 10" size Class 125 Figure 980-D only. Inlet isolating BFV not available for 12". Dimensions in inches, weight in pounds.
- All dimensions and weights are approximate. If critical request certified drawings